

**P1 PLASTIC MOLDED RUNNING BOARDS
07-18 TOYOTA TUNDRA DOUBLE CAB/CREWMAX**

PARTS LIST:

2	P1 Molded Running Boards	12	8-1.25 x 25mm Hex Bolts
1	Driver/Left Front Mounting Bracket	12	8mm x 28mm Flat Washers
1	Passenger/Right Front Mounting Bracket	12	8mm Lock Washers
1	Driver/Left Center Mounting Bracket	6	6mm Double Bolt Plates
1	Passenger/Right Center Mounting Bracket	12	6mm x 22mm Flat Washers
1	Driver/Left Rear Mounting Bracket	12	6mm Lock Washers
1	Passenger/Right Rear Mounting Bracket	12	6mm Hex Nuts

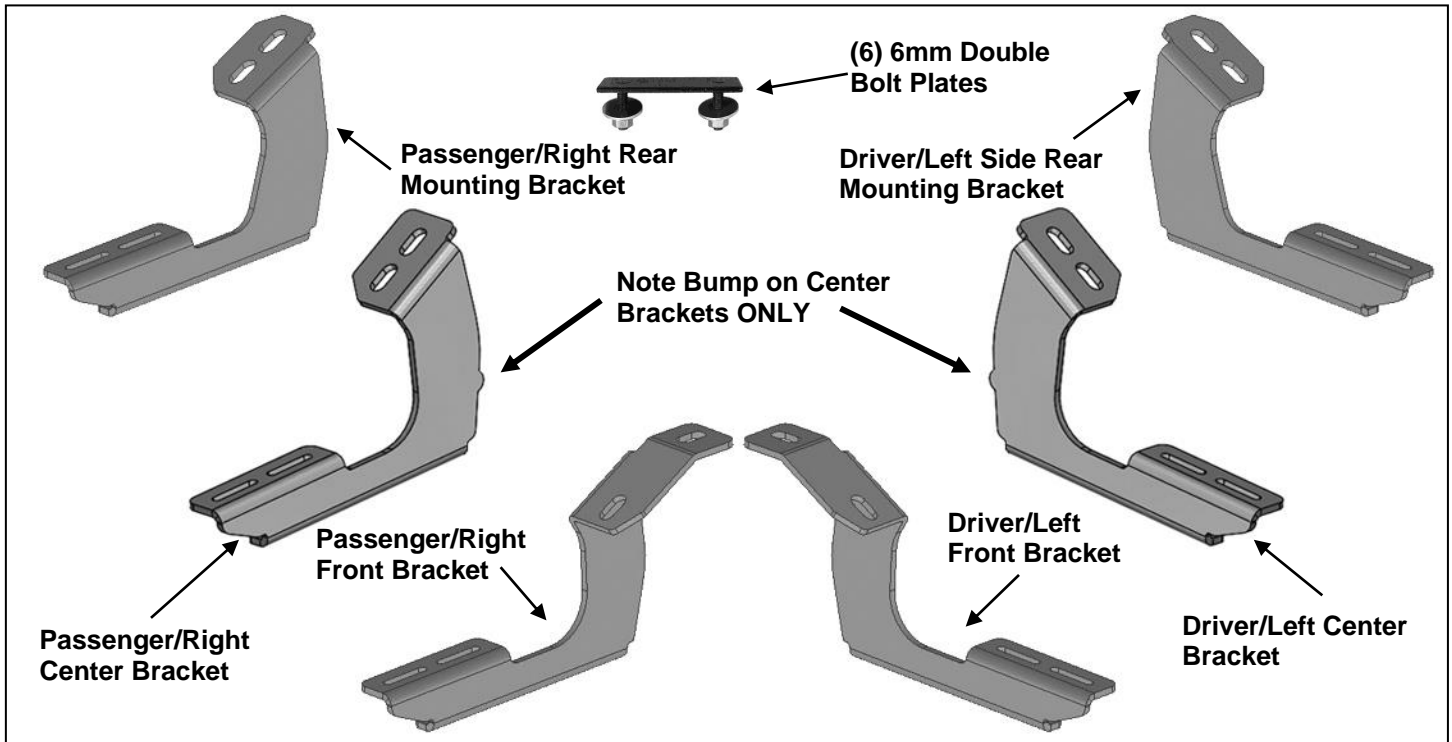

PROCEDURE:

- 1. REMOVE CONTENTS FROM BOX. VERIFY ALL PARTS ARE PRESENT. READ INSTRUCTIONS CAREFULLY. USE ILLUSTRATION TO IDENTIFY BRACKETS AND RUNNING BOARDS.**
- Starting on the passenger side, front of the vehicle, remove the plastic plugs or hex bolts covering the (2) threaded holes in the body panel, **(Figures 1 & 2)**. Select the passenger side front Mounting Bracket, **(Figure 3)**. Attach the Bracket to the vehicle using the included (2) 8mm Hex Bolts, (2) 8mm Lock Washers and (2) 8mm Flat Washers, **(Figure 3)**. Do not tighten hardware at this time.
- Next, move to the next (2nd) mounting location, **(Figure 1)**. **NOTE:** The Tundra has (4) mounting locations along the bottom of the body. **Installation will use the 1st, 2nd and 4th** mounting locations only for the Running Board Brackets.
- Select the passenger side center Mounting Bracket, **(Figure 4)**. **IMPORTANT:** The Center and Rear Brackets look similar but each one is unique. Use the illustration above and **Figure 4** to help identify each Bracket. Repeat **Step 2** to install the center Mounting Bracket, **(Figure 5)**.
- Continue to the last mounting location at the back of the cab, **(Figure 6)**. Repeat **Step 2** to install the passenger side rear Bracket, **(Figures 4 & 7)**. When properly installed, the cradles for the Running Board will face toward the rear.
- Once all (3) Brackets have been fully installed, carefully unwrap (1) Running Board. Place the Running Board on top of the (3) Brackets. Locate the channels in the bottom of the Running Board. Select (3) 8mm Double Bolt Plates, **(Figure 8)**. Insert the Bolt Plates into the channels in the bottom of the Running Board closest to the Brackets, **(Figure 9)**. Lift the Running Board up and guide the studs down through the Brackets.

**P1 PLASTIC MOLDED RUNNING BOARDS
07-18 TOYOTA TUNDRA DOUBLE CAB/CREWMAX**

7. Attach the Running Board to the Mounting Brackets with the included (6) 6mm Flat Washers, (6) 6mm Lock Washers and (6) 6mm Hex Nuts, **(Figure 10)**. Do not tighten at this time.
8. Level and adjust the Running Board as desired and tighten all hardware.
9. Repeat **Steps 2—8** for driver side Running Board installation.
10. Do periodic inspections to the installation to make sure that all hardware is secure and tight.

To protect your investment, wax this product after installing. Regular waxing is recommended to add a protective layer over the finish. Do not use any type of polish or wax that may contain abrasives that could damage the finish. Mild soap may be used to clean the P1 Running Board.

Passenger Side Installation Pictured

Remove plastic plugs or factory hex bolts (if equipped)

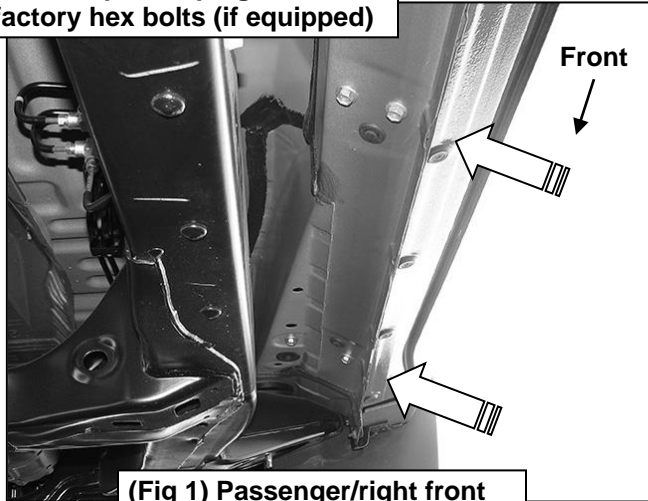

(Fig 1) Passenger/right front and center mounting location

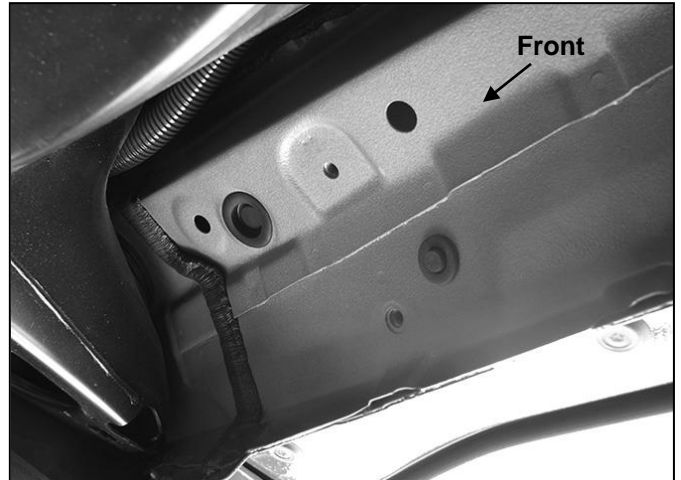

(Fig 2) Passenger/right front mounting location

- (2) 8mm Hex Bolts
- (2) 8mm Lock Washers
- (2) 8mm Flat Washers

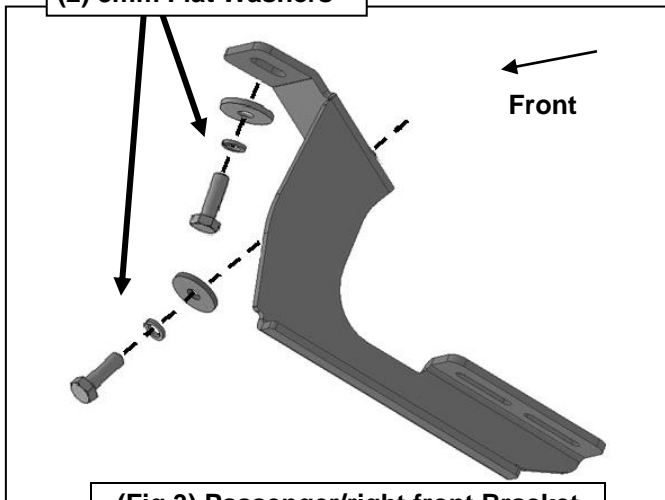

(Fig 3) Passenger/right front Bracket

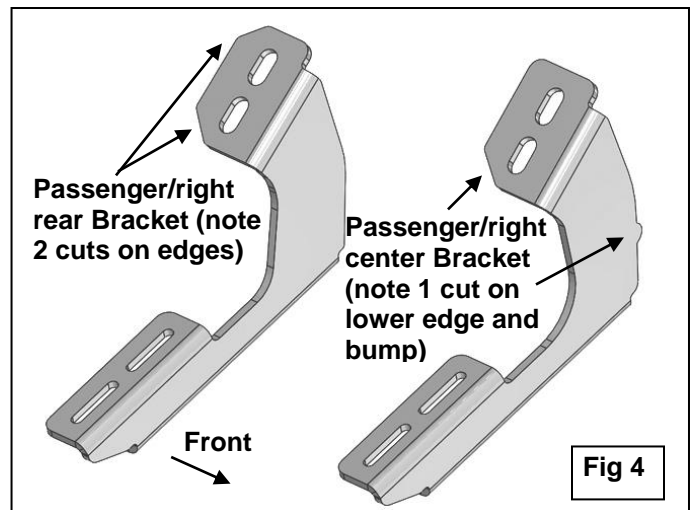
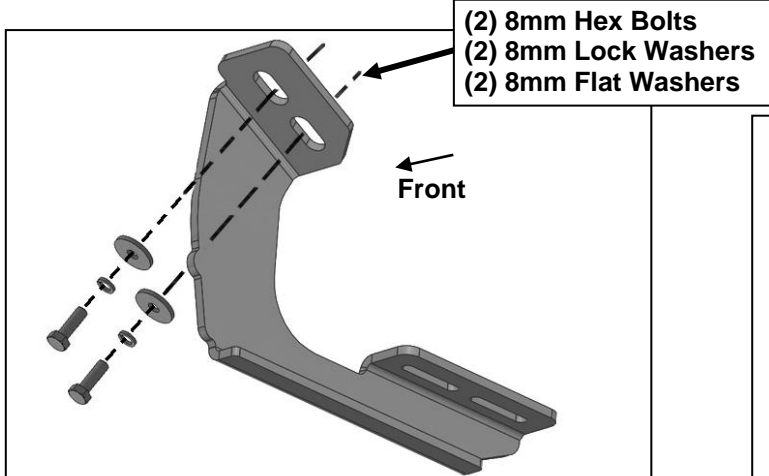

Fig 4

P1 PLASTIC MOLDED RUNNING BOARDS
07-18 TOYOTA TUNDRA DOUBLE CAB/CREWMAX

Passenger Side Installation Pictured



(Fig 5) Passenger/right center Bracket-note bump on back of bracket to identify center brackets only

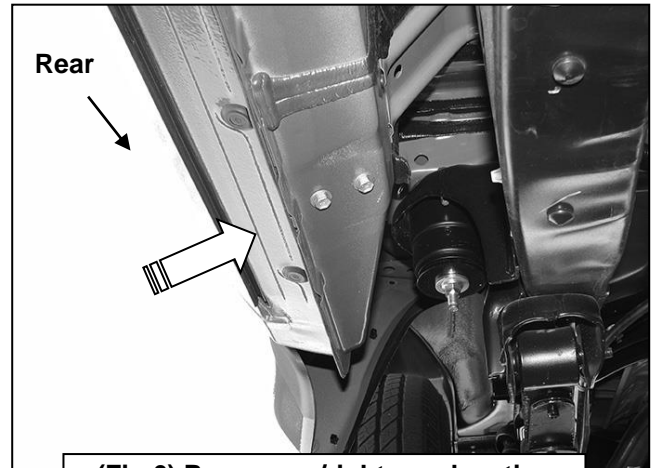

(Fig 6) Passenger/right rear location

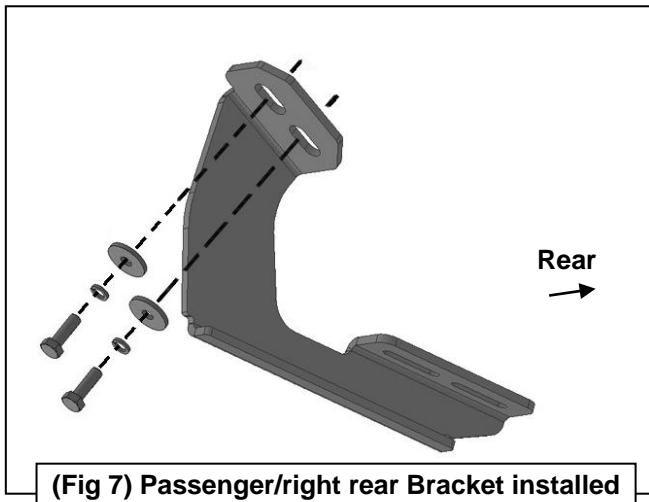

(Fig 7) Passenger/right rear Bracket installed

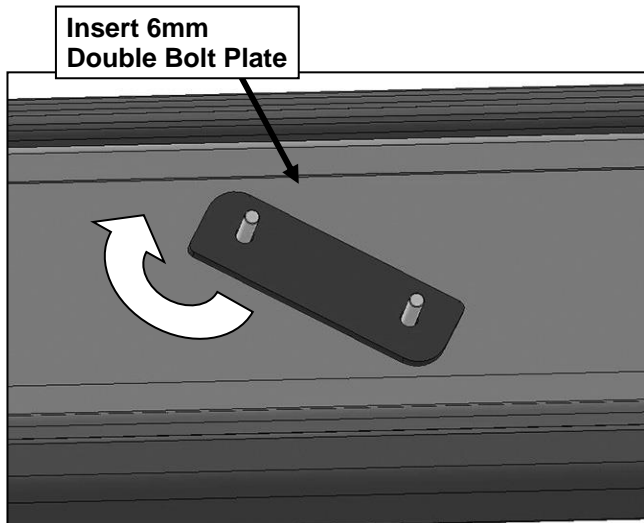

(Fig 9) Slide Double Bolt Plates into channels

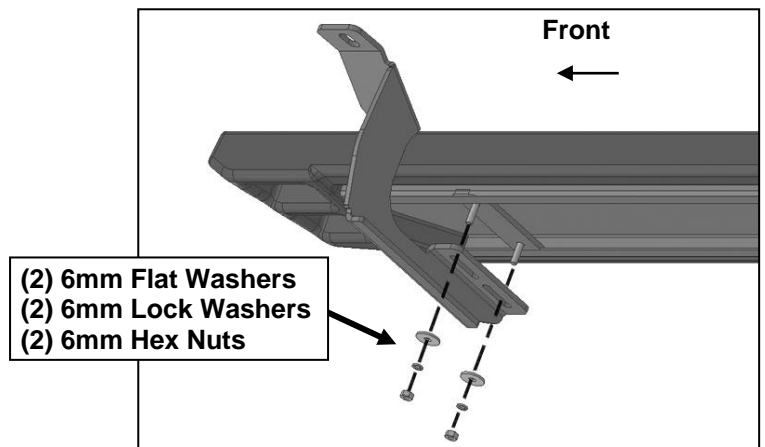

(Fig 10) Attach Running Board to Bracket