

**P1 PLASTIC MOLDED RUNNING BOARD
05-18 TACOMA DOUBLE CAB**

PARTS LIST:

2	78" P1 Running Boards	6	10mm x 27mm x 3mm Flat Washers
1	Driver/Left Front Mounting Bracket	4	10mm Lock Washers
1	Passenger/Right Front Mounting Bracket	4	10mm Hex Nuts
1	Driver/Left Center Mounting Bracket	12	8-1.25mm x 30mm Hex Bolts
1	Passenger/Right Center Mounting Bracket	12	8mm x 24mm x 2mm Flat Washers
1	Driver/Left Rear Mounting Bracket	12	8mm Lock Washers
1	Passenger/Right Rear Mounting Bracket	6	6mm Double Bolt Plates
1	Driver/Left Rear Support Bracket	12	6mm x 22mm x 2mm Flat Washers
1	Passenger/Right Rear Support Bracket	12	6mm Lock Washers
2	10mm Bolt Plates	12	6mm Hex Nuts
2	10-1.5mm x 30mm Hex Bolts		

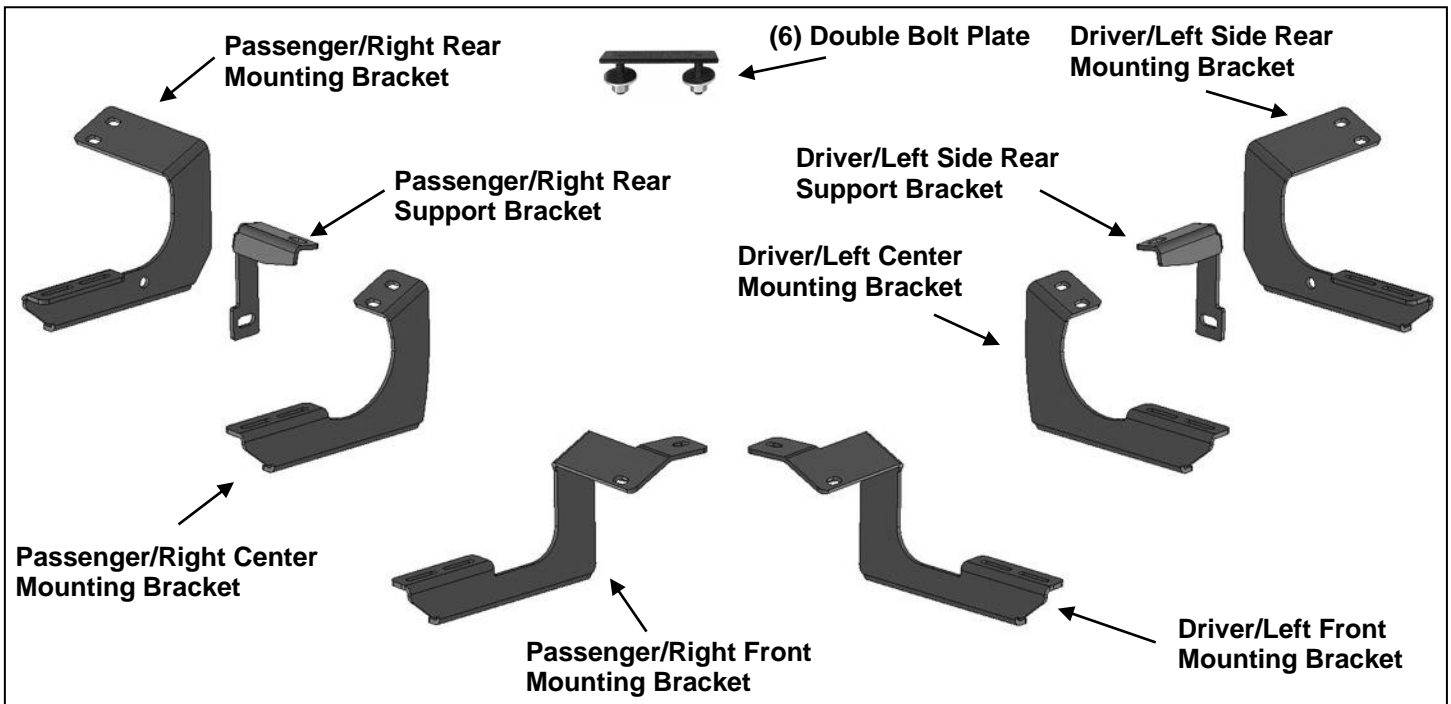

PROCEDURE:

- 1. REMOVE CONTENTS FROM BOX. VERIFY ALL PARTS ARE PRESENT. READ INSTRUCTIONS CAREFULLY. USE ILLUSTRATION TO IDENTIFY BRACKETS.**
- Starting on the passenger side front of the vehicle, remove the plastic plugs or hex bolts covering the (2) threaded holes in the body panel, **(Figure 1)**. Select the Passenger side Front Mounting Bracket, **(Figure 2)**. Bolt the Bracket to the body panel using the included (2) 8mm x 25mm Hex Bolts, (2) 8mm Lock Washers and (2) 8mm Flat Washers, **(Figure 2)**. Do not tighten hardware at this time.
- Next, move along the side of the vehicle to the next mounting location, **(Figure 3)**. Select the Passenger side Center Mounting Bracket, **(Figure 4)**. **IMPORTANT:** Use the picture above to help identify each Bracket. Repeat **Step 2** to install the Center Mounting Bracket, **(Figure 4)**.
- Continue to the last mounting location at the back of the cab, **(Figure 5)**. Repeat **Step 2** to install the Passenger side Rear Mounting Bracket, **(Figures 6 & 7)**. Select the Passenger side Rear Support Bracket. Insert (1) 10mm Bolt Plate into the hole in the pinch weld, **(Figure 7)**. Attach the Bracket to the Bolt Plate using (1) 10mm Flat Washer, (1) 10mm Lock Washer and (1) 10mm Hex Nut, **(Figures 6, 7 & 12)**. Attach the Bracket to the Rear Mounting Bracket using (1) 10mm Hex Bolt, (2) 10mm Flat Washers, (1) 10mm Lock Washer and (1) 10mm Hex Nut, **(Figures 6 & 12)**.

**P1 PLASTIC MOLDED RUNNING BOARD
05-18 TACOMA DOUBLE CAB**

5. Once all Brackets have been fully installed, select (1) Running Board. Locate the channels in the bottom of the Running Board. Select (3) 6mm Double Bolt Plates, **(Figure 8)**. Insert the Bolt Plates into the channels in the bottom of the Running Board closest to the Brackets, **(Figure 9)**. Lift the Running Board up and guide the studs through the Brackets.
6. Attach the Running Board to the Brackets with (6) 6mm Flat Washers, (6) 6mm Lock Washers and (6) 6mm Hex Nuts, **(Figure 10—12)**. **NOTE:** The Running Board is designed to fit close to the vehicle. It may be necessary to loosen the Bracket hardware slightly and tilt the Brackets downward to insert the Running Board between the Brackets and the body.
7. Level and adjust the Running Board as necessary and fully tighten all hardware.
8. Repeat **Steps 2—7** for driver side Running Board installation.
9. Do periodic inspections to the installation to make sure that all hardware is secure and tight.

To protect your investment, wax this product after installing. Regular waxing is recommended to add a protective layer over the finish. Do not use any type of polish or wax that may contain abrasives that could damage the finish. Mild soap may be used to clean the Running Board.

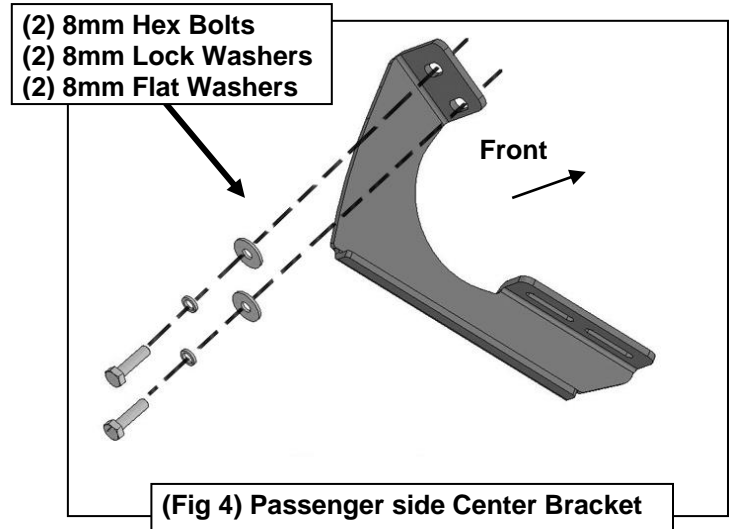
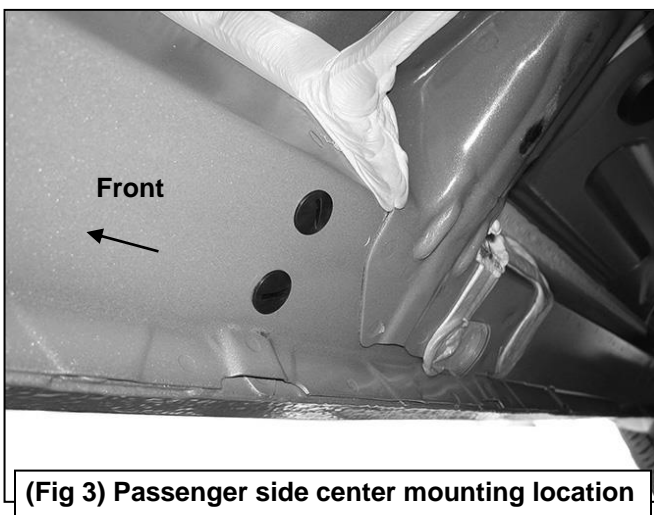
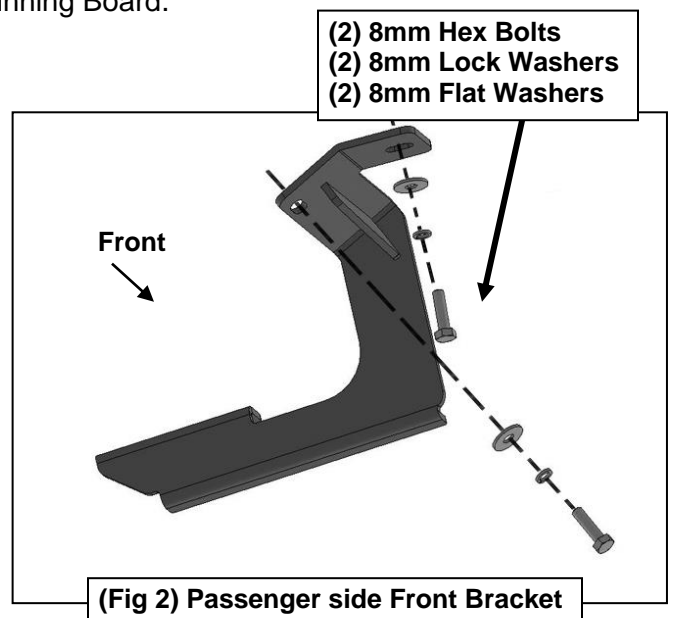
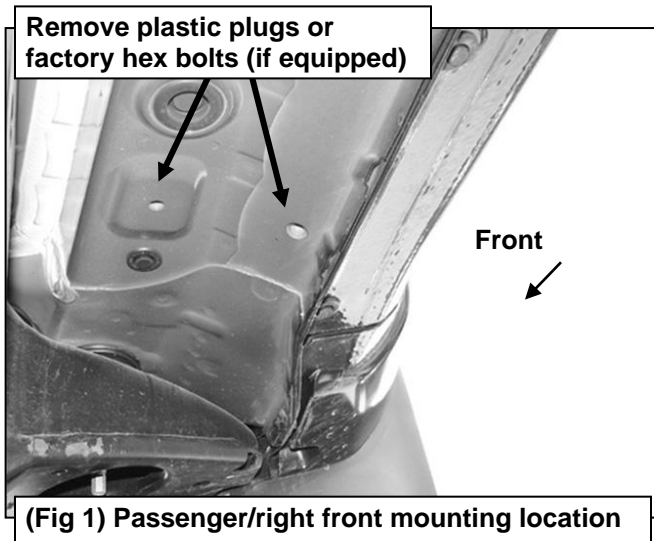

**P1 PLASTIC MOLDED RUNNING BOARD
05-18 TACOMA DOUBLE CAB**

Passenger Side Installation Pictured

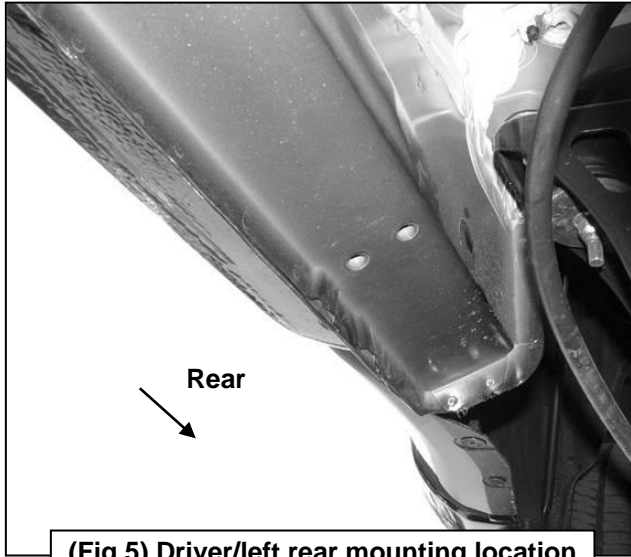

(Fig 5) Driver/left rear mounting location

Attach Bracket to pinch weld:
(1) 10mm Bolt Plate
(1) 10mm Flat Washer
(1) 10mm Lock Washer
(1) 10mm Hex Nut

(2) 8mm Hex Bolts
(2) 8mm Lock Washers
(2) 8mm Flat Washers

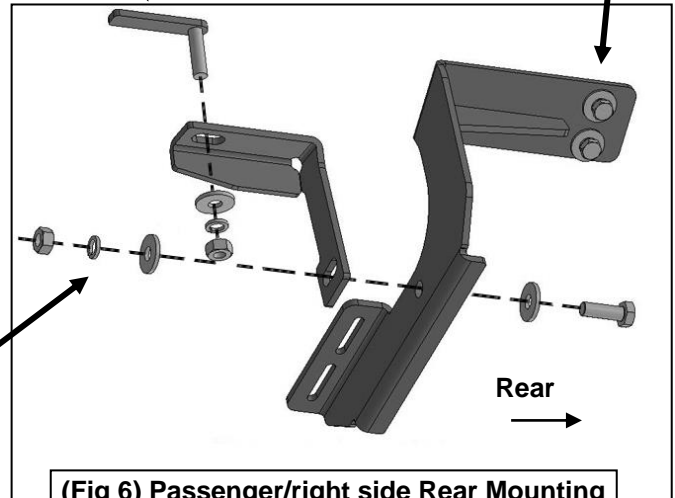

(Fig 6) Passenger/right side Rear Mounting and Support Bracket illustrated

Attach Bracket to Bracket:
(1) 10mm Hex Bolt
(2) 10mm Flat Washers
(1) 10mm Lock Washer
(1) 10mm Hex Nut

Insert 10mm Bolt Plate in through pinch weld hole

(2) 8mm Hex Bolts
(2) 8mm Lock Washers
(2) 8mm Flat Washers

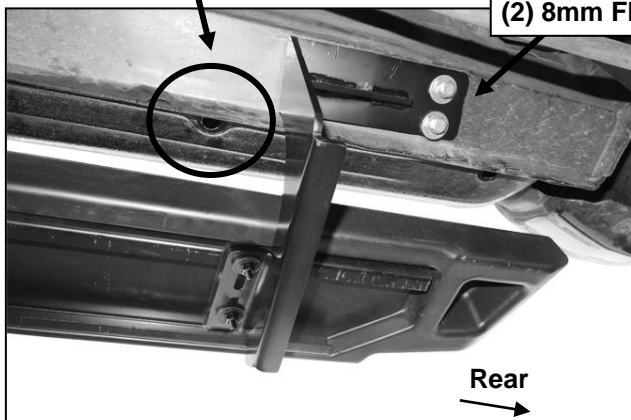

(Fig 7) Passenger side Rear Support Bracket mounting location on pinch weld



(Fig 8) 6mm Double Bolt Plate

**P1 PLASTIC MOLDED RUNNING BOARD
05-18 TACOMA DOUBLE CAB**

Passenger Side Installation Pictured

