

**PARTS LIST:**

2	91" S6 Running Boards	2	Passenger/Right Rear Mounting Brackets
1	Driver/Left Front Mounting Bracket	8	8-1.25mm x 35mm Double Bolt Plates
1	Passenger/Right Front Mounting Bracket	16	8-1.25 x 30mm Hex Bolts
1	Driver/Left Center Mounting Bracket	32	8mm x 24mm x 2mm Flat Washers
1	Passenger/Right Center Mounting Bracket	16	8mm Lock Washers
2	Driver/Left Rear Mounting Brackets	16	8-1.25mm Nylon Lock Nuts

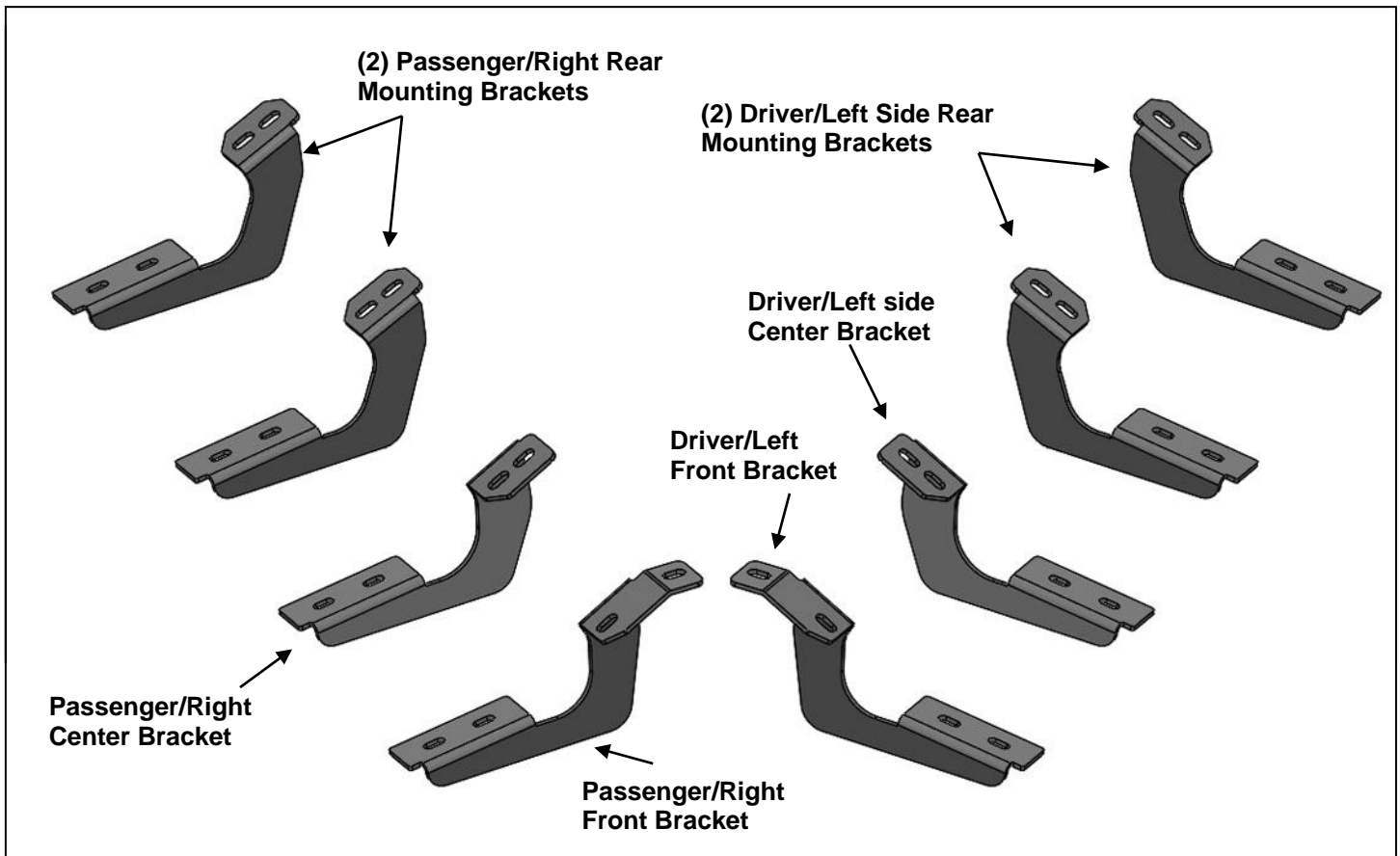

**PROCEDURE:**

1. REMOVE CONTENTS FROM BOX. VERIFY ALL PARTS ARE PRESENT. READ INSTRUCTIONS CAREFULLY. USE ILLUSTRATION TO IDENTIFY BRACKETS AND RUNNING BOARDS.
2. Starting on the driver side, front of the vehicle, remove the plastic plugs or hex bolts covering the (2) threaded holes in the body panel, **(Figure 1)**. Select the driver side Front Mounting Bracket, **(Figure 2)**. Attach the Bracket to the vehicle using the included (2) 8mm Hex Bolts, (2) 8mm Lock Washers and (2) 8mm Flat Washers, **(Figure 3)**. Do not tighten hardware at this time.
3. Next, move to the 2nd mounting location, **(Figure 5)**. Select the driver side center Mounting Bracket, **(Figure 4)**. **IMPORTANT:** The Center and Rear Brackets look similar but each one is unique. Use the illustration above and **Figure 4** to help identify each Bracket. Repeat **Step 2** to install the center Mounting Bracket, **(Figure 6)**.
4. Move along to the 3rd mounting location, **(Figures 7)**. Repeat **Step 2** to install (1) Driver side Rear Mounting Bracket, **(Figure 8)**.
5. Continue to the last, 4th, mounting location at the back of the cab, **(Figure 9)**. Repeat **Step 2** to install the (1) Driver side Rear Bracket, **(Figure 10)**. When properly installed, the cradles on the Brackets will face toward the rear.
6. Once all (4) Brackets have been fully installed, carefully unwrap (1) Running Board. Place the Running Board on top of the (4) Brackets. Locate the channel in the bottom of the Running Board. Select (3) 8mm Double Bolt Plates, **(Figure 11)**. Insert the Bolt Plates into the channel in the bottom of the

Running Board closest to the Brackets, **(Figure 12)**. Lift the Running Board up and guide the studs down through the Brackets.

7. Attach the Running Board to the Mounting Brackets with the included (8) 8mm Flat Washers and (8) 8mm Nylon Lock Nuts, **(Figures 13—17)**. Do not tighten at this time.
8. Level and adjust the Running Board as desired and tighten all hardware.
9. Repeat **Steps 2—8** for passenger/right side Running Board installation.
10. Do periodic inspections to the installation to make sure that all hardware is secure and tight.

**To protect your investment**, wax this product after installing. Regular waxing is recommended to add a protective layer over the finish. Do not use any type of polish or wax that may contain abrasives that could damage the finish. Mild soap may be used to clean the Running Board.

### Driver/left Side Installation Pictured

Remove plastic plugs or factory hex bolts (if equipped)

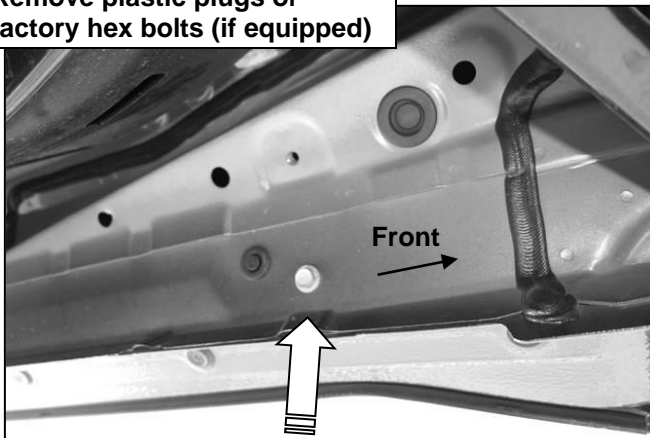

**(Fig 1) Driver/left side front mounting location**

(2) 8mm Hex Bolts  
(2) 8mm Lock Washers  
(2) 8mm Flat Washers

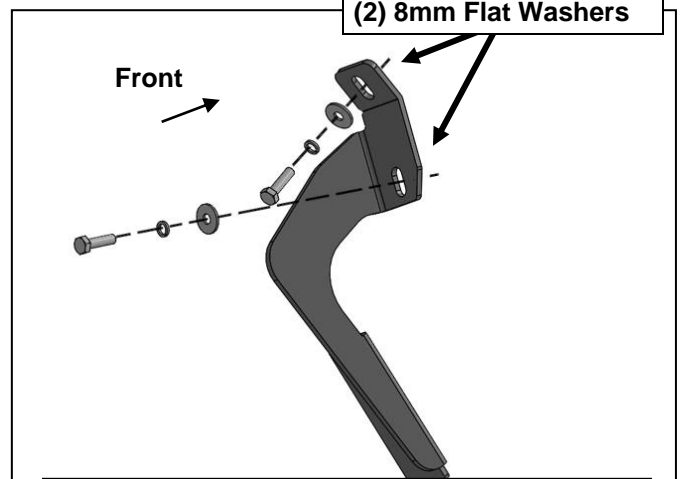

**(Fig 2) Driver/left side front mounting location**

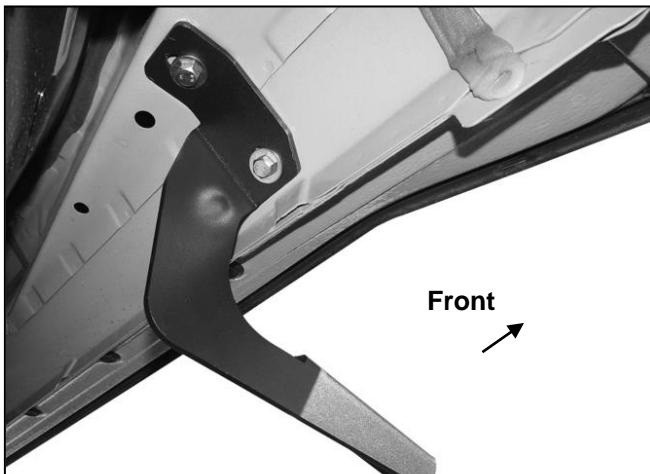

**(Fig 3) Driver/left side front Bracket installed**

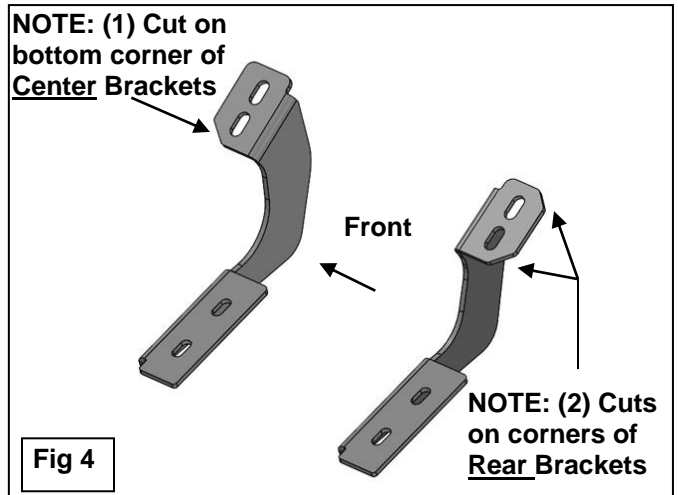

### Driver/left Side Installation Pictured

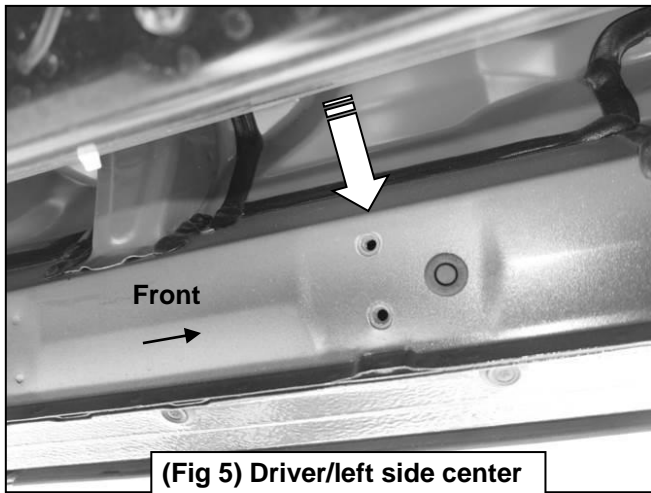

(Fig 5) Driver/left side center Bracket mounting location

- (2) 8mm Hex Bolts
- (2) 8mm Lock Washers
- (2) 8mm Flat Washers

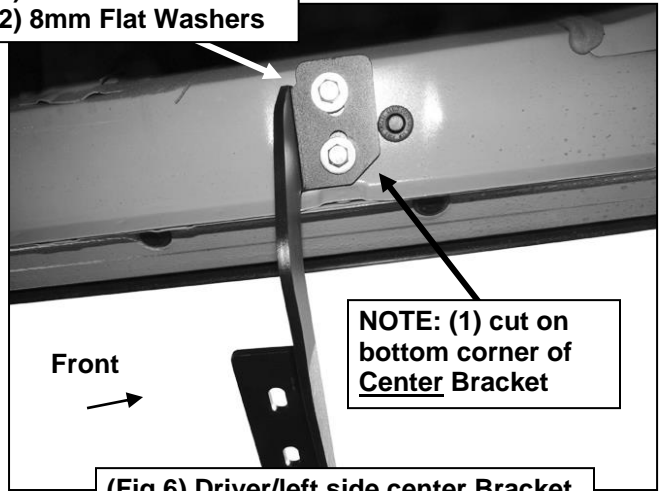

(Fig 6) Driver/left side center Bracket

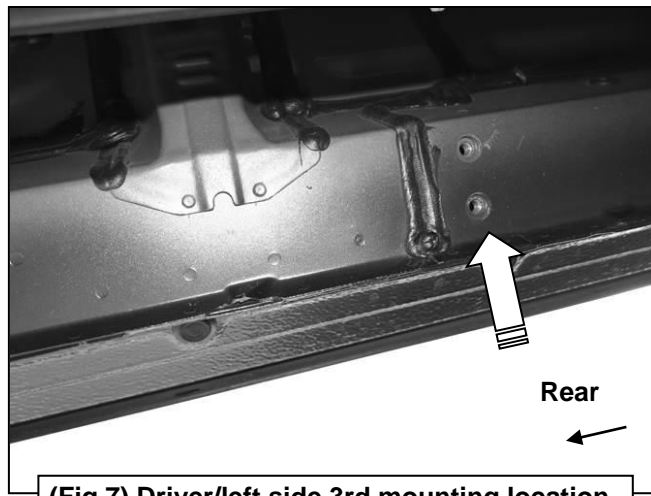

(Fig 7) Driver/left side 3rd mounting location

- NOTE: (2) Cuts on corners of Rear Brackets

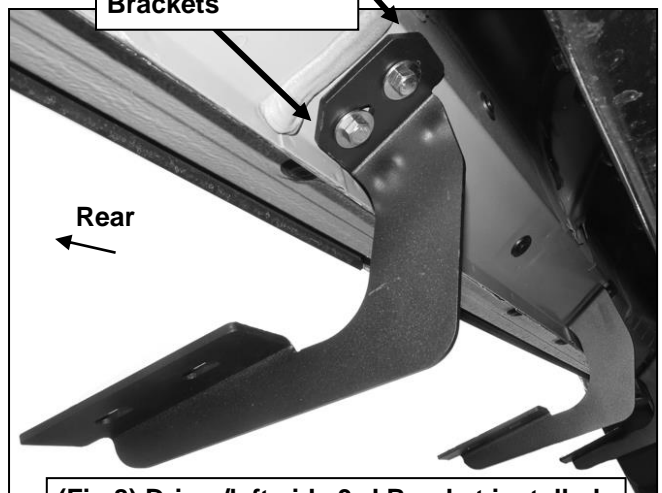

(Fig 8) Driver/left side 3rd Bracket installed

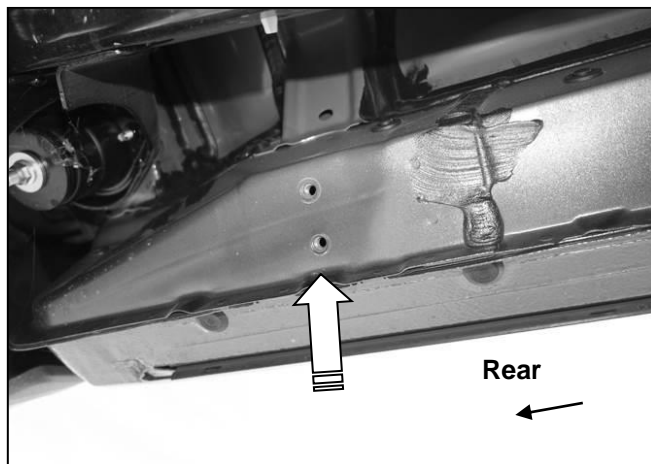

(Fig 9) Driver/left side 4th mounting location

### Driver/left Side Installation Pictured

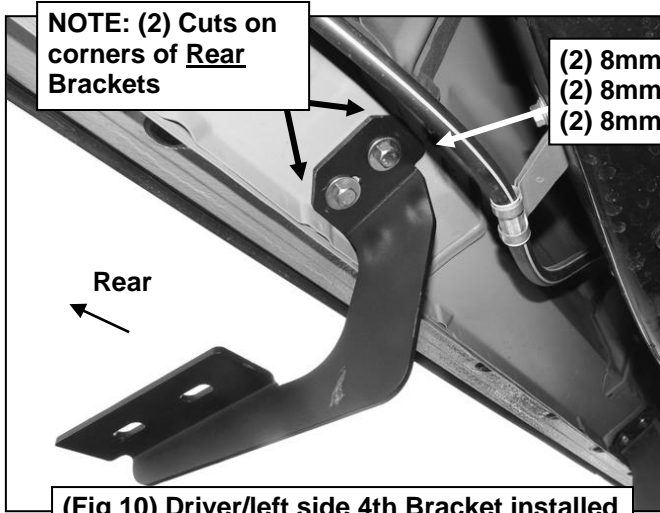

(Fig 10) Driver/left side 4th Bracket installed

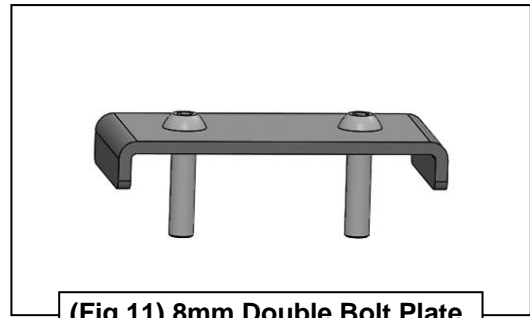

(Fig 11) 8mm Double Bolt Plate

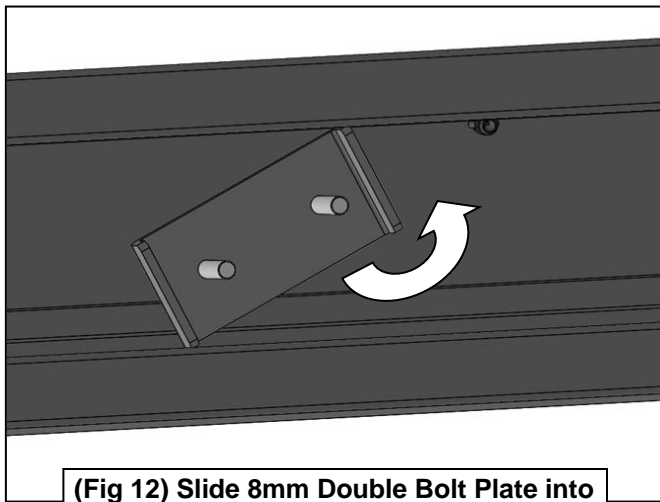

(Fig 12) Slide 8mm Double Bolt Plate into channel on bottom of Running Board

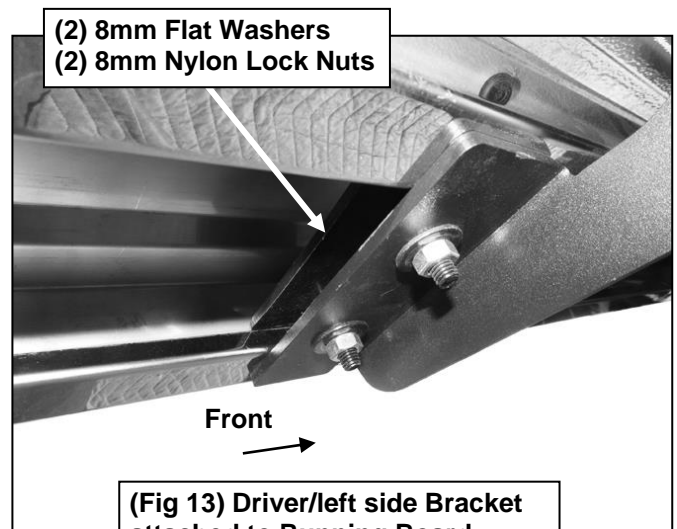

(Fig 13) Driver/left side Bracket attached to Running Board

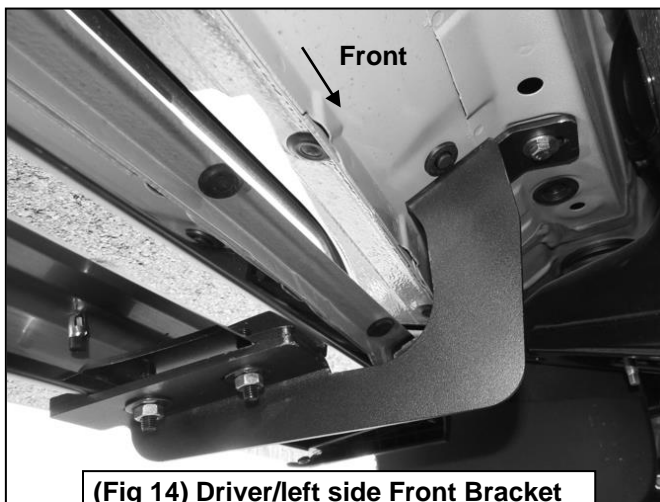

(Fig 14) Driver/left side Front Bracket attached to Running Board

### Driver/left Side Installation Pictured

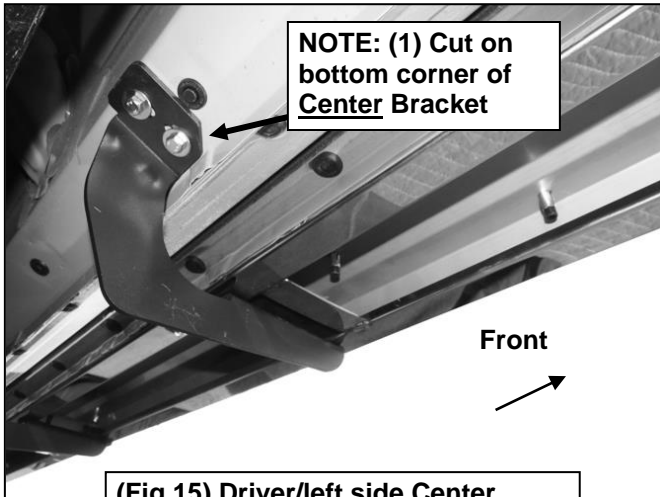

(Fig 15) Driver/left side Center Bracket attached to Running Board

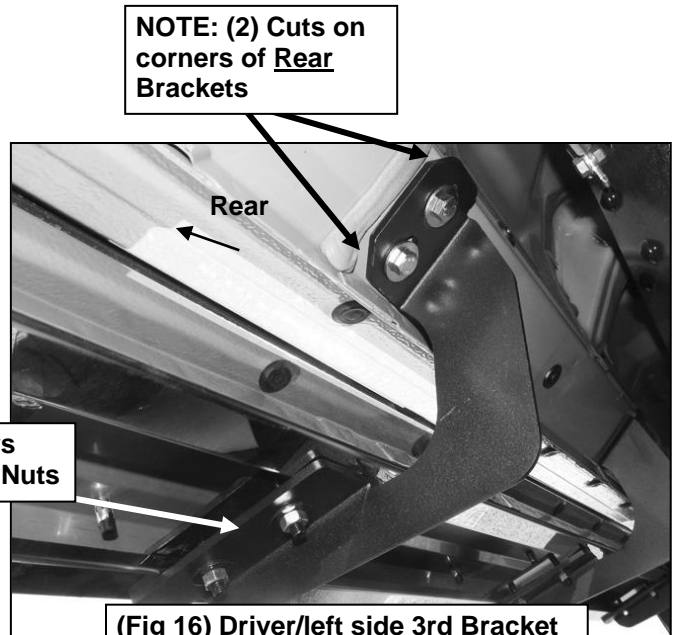

(Fig 16) Driver/left side 3rd Bracket attached to Running Board

- (2) 8mm Flat Washers
- (2) 8mm Nylon Lock Nuts

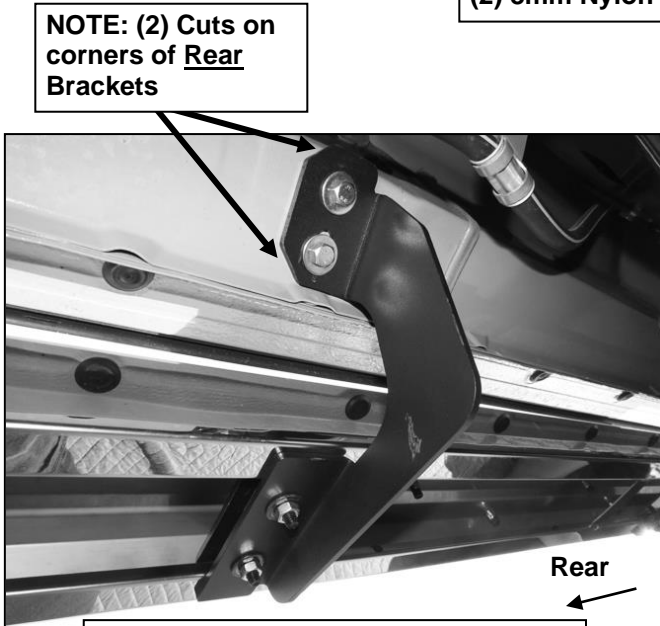

(Fig 17) Driver/left side 4th Bracket attached to Running Board

