

PARTS LIST:

1	Driver/Left S6 Running Board	6	8mm x 35mm Double Bolt Plates
1	Passenger/Right S6 Running Board	12	8mm x 30mm Hex Bolts
1	Driver/Left Front Mounting Bracket	12	8mm Lock Washers
1	Passenger/Right Front Mounting Bracket	24	8mm x 24mm OD x 2mm Flat Washers
2	Driver/Left Center and Rear Mounting Brackets	12	8mm Nylon Lock Nuts
2	Passenger/Right Center and Rear Mounting Brackets		

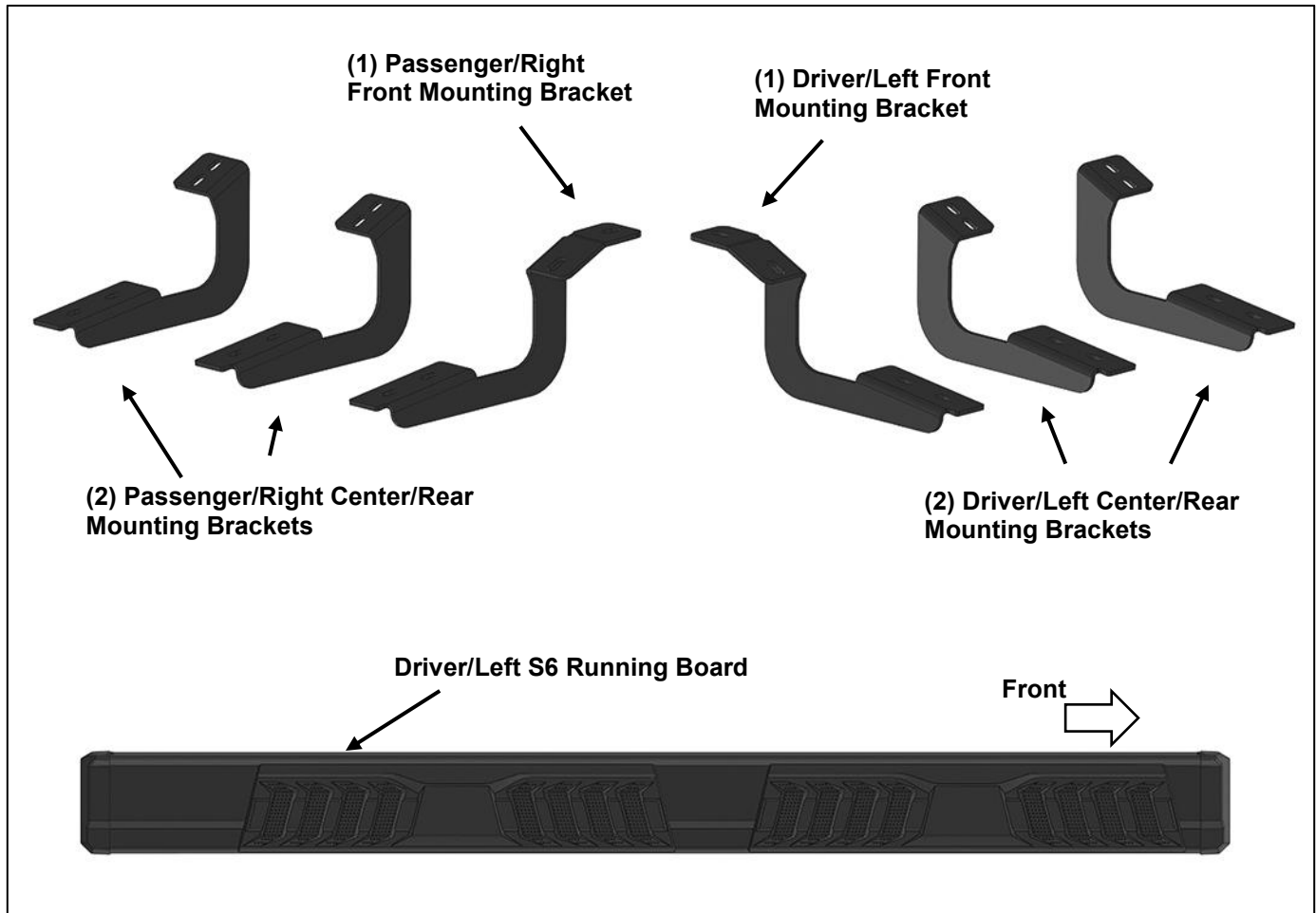

PROCEDURE:

1. REMOVE CONTENTS FROM BOX. VERIFY ALL PARTS ARE PRESENT. READ INSTRUCTIONS CAREFULLY. USE ILLUSTRATION TO IDENTIFY BRACKETS AND RUNNING BOARDS.
2. Starting on the Driver/Left front of the vehicle, remove the plastic plugs, (or hex bolts), covering the threaded holes in the body panel, **(Figure 1)**. Select the Driver/Left Front Mounting Bracket. Attach the Bracket to the vehicle with (2) 8mm Hex Bolts, (2) 8mm Lock Washers and (2) 8mm Flat Washers, **(Figure 2)**. Do not tighten hardware at this time.
3. Move along the body panel to the center mounting location. Select (1) Driver/Left Center/Rear Mounting Bracket. Repeat **Step 2** to install the Mounting Bracket, **(Figures 3 & 4)**. Do not tighten hardware.
4. Continue to the last mounting location at the back of the cab, **(Figure 5)**. Select the remaining (1) Driver/Left Center/Rear Mounting Bracket. Repeat **Step 2** to attach the Mounting Bracket. Do not tighten hardware.
5. Select (3) Double Bolt Plates. Insert the Bolt Plates into the channel in the bottom of the Running Board closest to the Brackets, **(Figure 6)**. Lift the Running Board up and guide the studs through the Brackets.
6. Select the Driver/Left S6 Running Board. Attach the Running Board to the Mounting Brackets with (6) 8mm Flat Washers and (6) 8mm Nylon Lock Nuts, **(Figure 7)**. Do not tighten hardware.
7. Level and adjust the Running Board and tighten all hardware.

8. Repeat **Steps 2—7** to attach the Passenger/Right S6 Running Board.
9. Do periodic inspections to the installation to make sure that all hardware is secure and tight.

To protect your investment, Do not use any type of polish or wax that may contain abrasives that could damage the finish. Mild soap may be used to clean the Running Boards.

Driver Side Installation Pictured

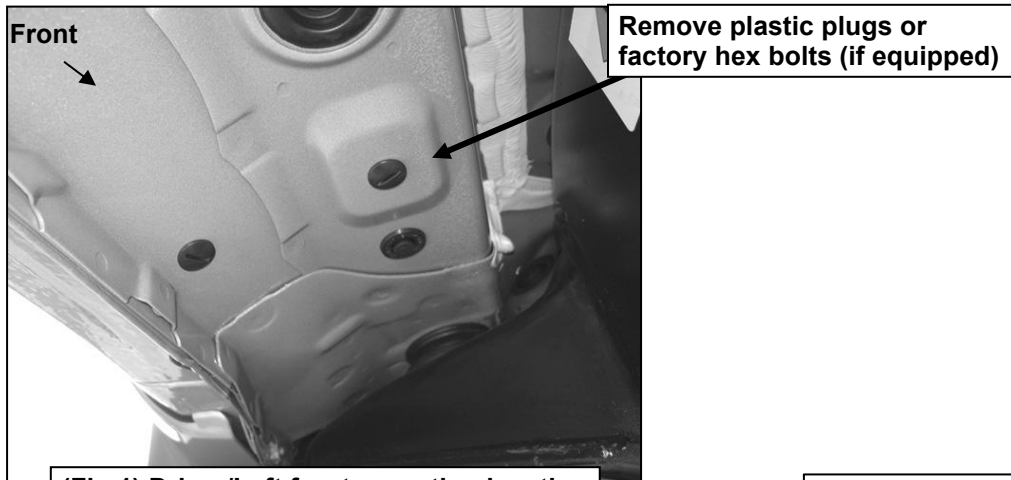

- (2) 8mm Hex Bolts
- (2) 8mm Lock Washers
- (2) 8mm Flat Washers

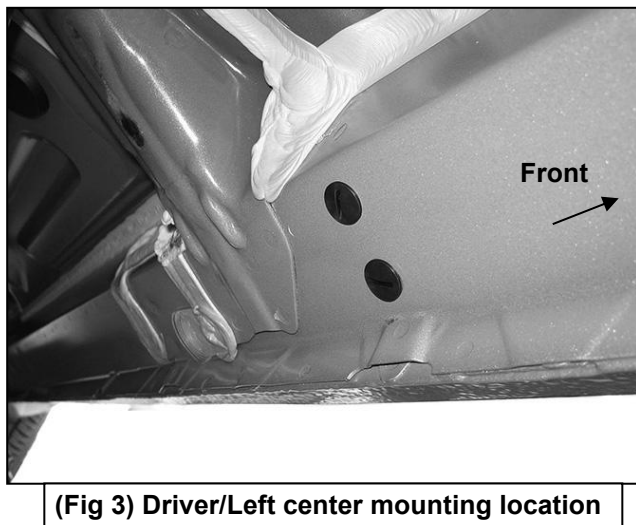
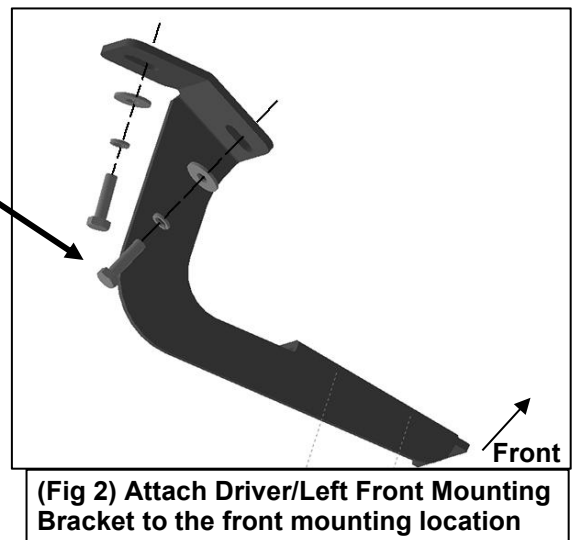

Driver Side Installation Pictured

- (2) 8mm Hex Bolts
- (2) 8mm Lock Washers
- (2) 8mm Flat Washers

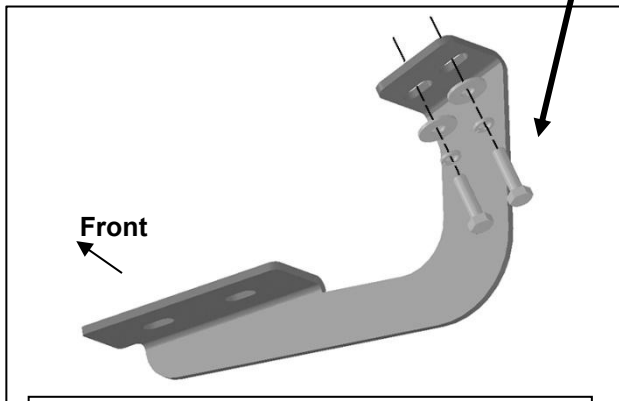

(Fig 4) Attach Driver/Left Center/Rear Mounting Brackets to the center and rear mounting locations

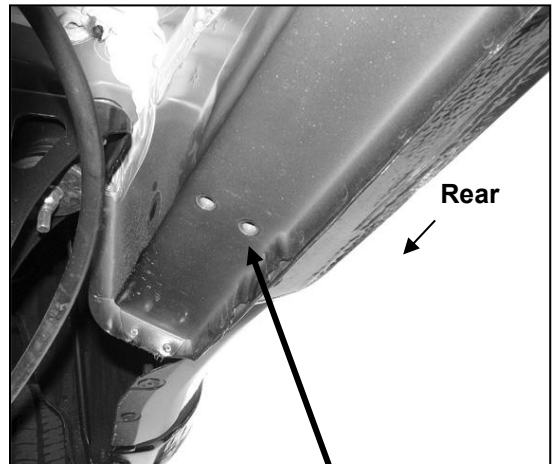

(Fig 5) Driver/Left rear mounting location

8mm Double Bolt Plate

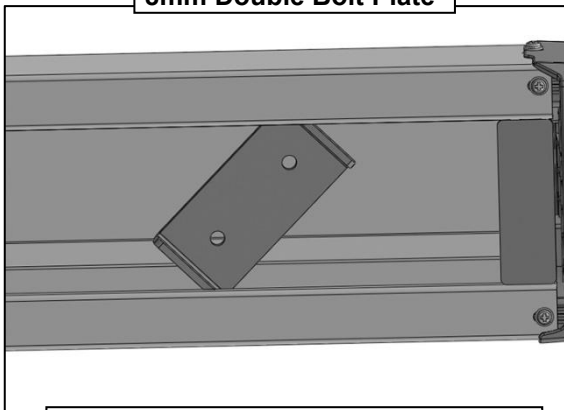

(Fig 6) Insert Bolt Plate in the bottom of the channel on the Running Board

- (2) 8mm Flat Washers
- (2) 8mm Nylon Lock Nuts

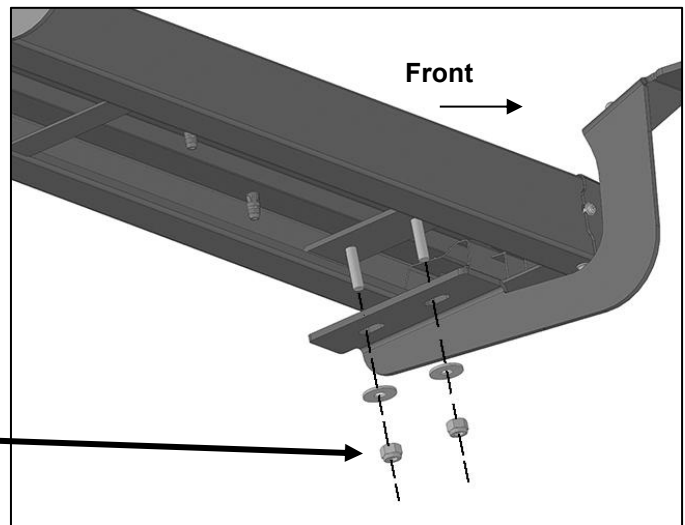

(Fig 7) Attach Driver/Left Running Board to the Mounting Brackets