

PARTS LIST:

1	Driver/Left Running Board	16	8mm x 30mm Hex Bolts
1	Passenger/Right Running board	16	8mm Lock Washers
1	Driver/Left Front Mounting Bracket	32	8mm x 24mm OD x 2mm Flat Washers
1	Passenger/Right Front Mounting Bracket	16	8mm Nylon Lock Nuts
3	Driver/Left Rear Mounting Brackets	8	8mm x 35mm Double Bolt Plates
3	Passenger/Right Rear Mounting Brackets		

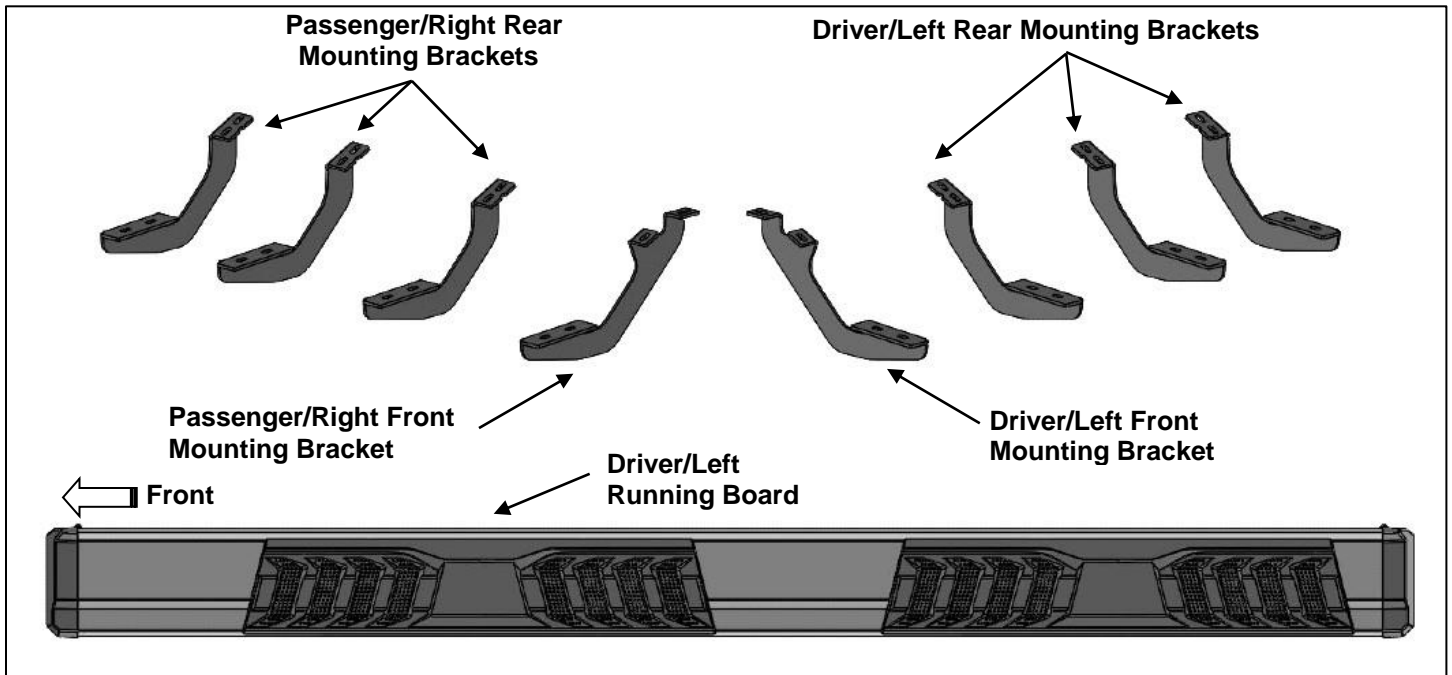

PROCEDURE:

1. REMOVE CONTENTS FROM BOX. VERIFY ALL PARTS ARE PRESENT. READ INSTRUCTIONS CAREFULLY. USE ILLUSTRATION TO IDENTIFY BRACKETS AND RUNNING BOARDS.
2. Starting on the Driver/Left front of the vehicle, remove the plastic plugs or hex bolts covering the (2) threaded holes in the floor panel, **(Figure 1)**.
3. Select Driver/Left Front Mounting Bracket, **(Figure 2)**. Attach the Bracket to the panel with (2) 8mm Hex Bolts, (2) 8mm Lock Washers and (2) 8mm Flat Washers, **(Figure 2)**. Do not tighten hardware.
4. Next, move to the second mounting location, **(Figure 3)**. Select (1) Driver/Left Rear Mounting Bracket. Repeat **Step 3** to attach the Bracket to the floor panel, **(Figure 4)**.
5. Continue to the rear mounting location, **(Figures 5 & 6)**. Repeat **Step 3** to attach (1) Driver/Left Rear Mounting Bracket to the 3rd and 4th mounting locations.
6. Select the Driver/Left Running Board. Select (4) Double Bolt Plates. Insert the Bolt Plates into the channel in the bottom of the Running Board closest to the Brackets, **(Figure 7)**. Lift the Running Board up and guide the studs through the Brackets.
7. Attach the Running Board to the Mounting Brackets with (8) 8mm Flat Washers and (8) 8mm Nylon Lock Nuts, **(Figure 8)**. Do not tighten hardware.
8. Level and adjust the Running Board and tighten all hardware.
9. Repeat **Steps 2—8** to attach the Passenger/Right Running Board.
10. Do periodic inspections to the installation to make sure that all hardware is secure and tight.

To protect your investment, Do not use any type of polish or wax that may contain abrasives that could damage the finish. Mild soap may be used to clean the Running Boards.

Driver/Left Side Installation Pictured

Remove plastic plugs or
factory hex bolts (if equipped)

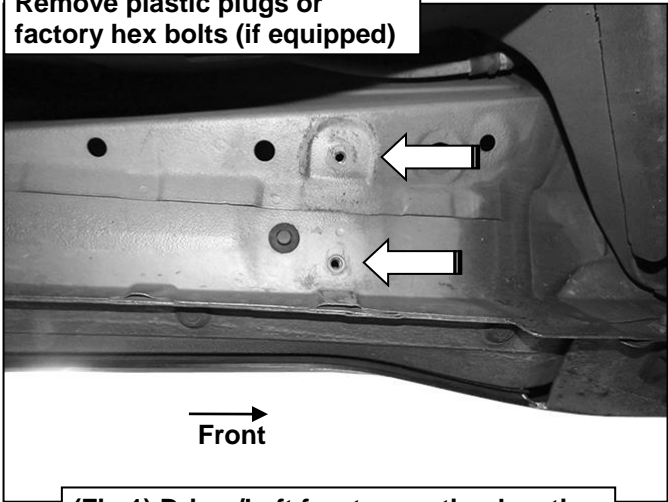

(Fig 1) Driver/Left front mounting location

- (2) 8mm Hex Bolts
- (2) 8mm Lock Washers
- (2) 8mm Flat Washers

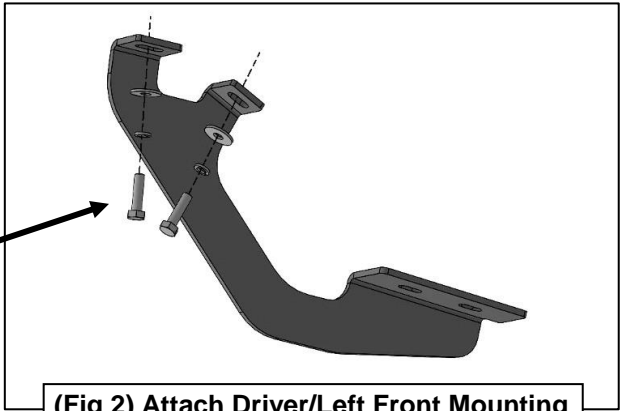

(Fig 2) Attach Driver/Left Front Mounting Bracket to the floor panel

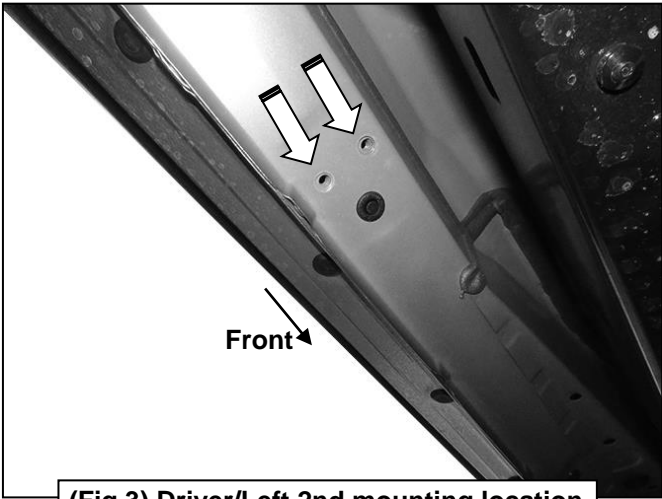

(Fig 3) Driver/Left 2nd mounting location

- (2) 8mm Hex Bolts
- (2) 8mm Lock Washers
- (2) 8mm Flat Washers

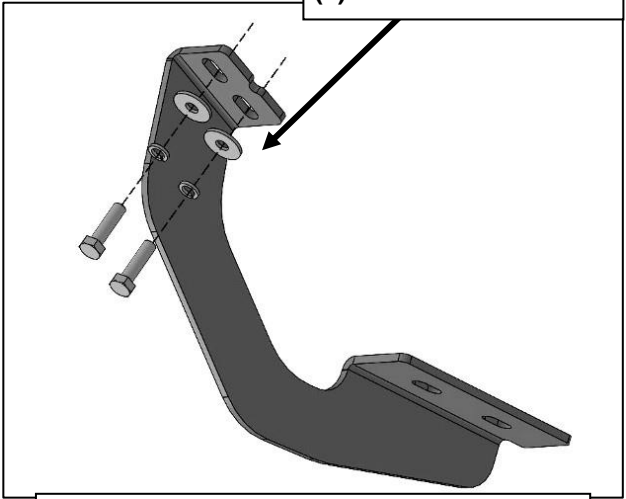

(Fig 4) Attach Driver/Left Rear Mounting Bracket to the floor panel

Driver/Left Side Installation Pictured

Remove plastic plugs or
factory hex bolts (if equipped)

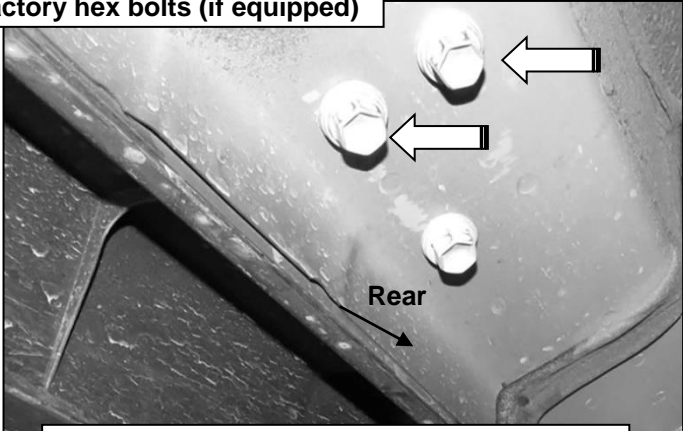

(Fig 5) Driver/Left 3rd rear mounting location

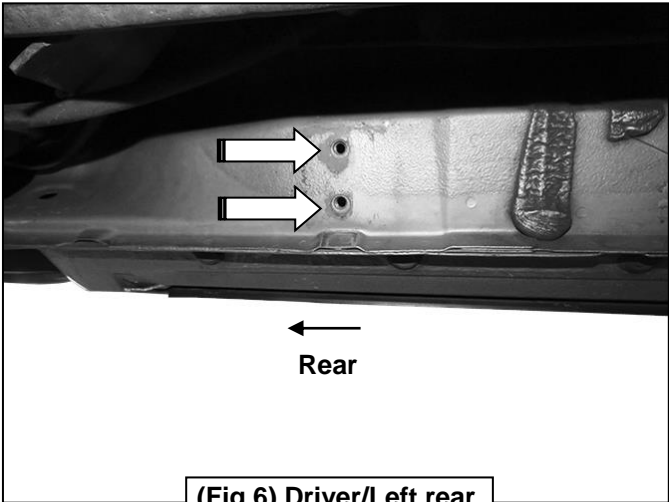

(Fig 6) Driver/Left rear
mounting location

8mm Double Bolt Plates

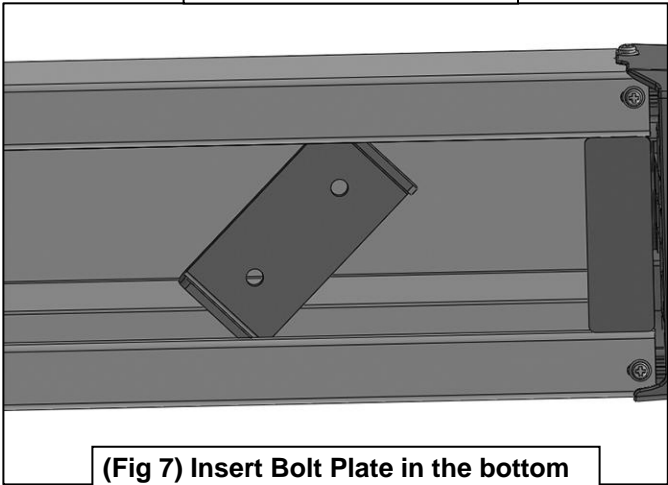

(Fig 7) Insert Bolt Plate in the bottom
of the channel on the Running Board

(2) 8mm Flat Washers
(2) 8mm Nylon Lock Nuts

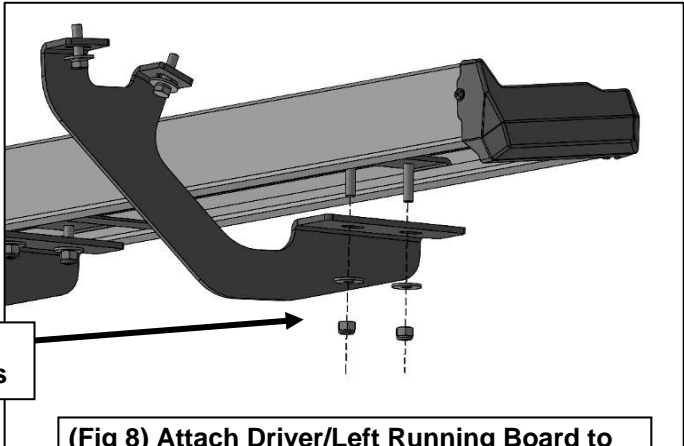

(Fig 8) Attach Driver/Left Running Board to
the Mounting Brackets