

PARTS LIST:

1	Driver/Left Tube	12	10mm x 30mm Hex Bolts
1	Passenger/Right Tube	24	10mm x 20mm OD x 2mm Flat Washers
4	Drop Steps	12	10mm Nylon Lock Nuts
1	Driver/Left Front Mounting Bracket	8	8mm Triangle Double Bolts Plates
1	Passenger/Right Front Mounting Bracket	12	8mm x 30mm Hex Bolts
1	Driver/Left Center Mounting Bracket	28	8mm x 22mm OD x 2mm Flat Washers
1	Passenger/Right Center Mounting Bracket	12	8mm Lock Washers
1	Driver/Left Rear Mounting Bracket	16	8mm Nylon Lock Nuts
1	Passenger/Right Rear Mounting Bracket		

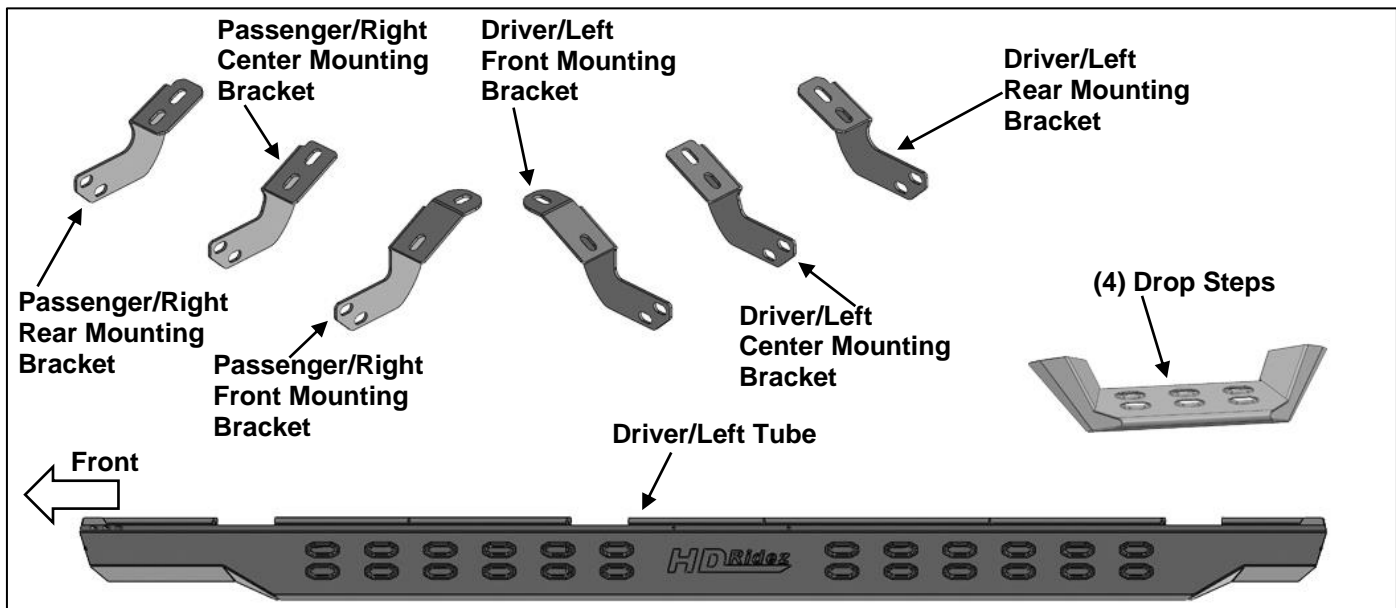

PROCEDURE:

- 1. REMOVE CONTENTS FROM BOX. VERIFY ALL PARTS ARE PRESENT. READ INSTRUCTIONS CAREFULLY. USE ILLUSTRATION TO IDENTIFY BRACKETS AND SIDE STEPS.**
- Starting on the Driver/Left front of the vehicle, remove the plastic plugs or hex bolts covering the (2) threaded holes in the floor panel, **(Figure 1)**.
- Select Driver/Left Front Mounting Bracket, **(Figure 2)**. Attach the Bracket to the panel with (2) 8mm Hex Bolts, (2) 8mm Lock Washers and (2) 8mm Flat Washers, **(Figure 2)**. Do not tighten hardware.
- Next, move to the second mounting location, **(Figure 3)**. Select (1) Center Mounting Bracket. Repeat **Step 3** to attach the Bracket to the floor panel, **(Figure 4)**.
- Continue to the rear mounting location. Repeat **Step 3** to attach (1) Rear Mounting Bracket to the floor panel.
- Select the Driver/Left Tube. Insert (2) 8mm Triangle Double Bolt Plates into the front (2) sets of (2) holes, **(Figure 5)**. Attach (1) Drop Step to the (2) Double Bolt Plates with (4) 8mm x 22mm Flat Washers and (4) 8mm Nylon Lock Nuts, **(Figure 6)**. Do not tighten hardware.
- With assistance, line up the mounting tabs in the Driver/Left Tube to the rear faces of the Mounting Brackets. Secure the Tube to the Mounting Brackets with (6) 10mm Hex Bolts, (12) 10mm x 20mm Flat Washers and (6) 10mm Nylon Lock Nuts, **(Figure 7)**. Do not tighten hardware.
- Level and adjust the Overland Step, then tighten all hardware.
- Repeat **Steps 1—8** to attach the Passenger/Right Overland Step.
- Do periodic inspections to the installation to make sure that all hardware is secure and tight.

To protect your investment, Do not use any type of polish or wax that may contain abrasives that could damage the finish. Mild soap may be used to clean the Overland Sliders.

Driver/Left Side Installation Pictured

Remove plastic plugs or
factory hex bolts (if equipped)

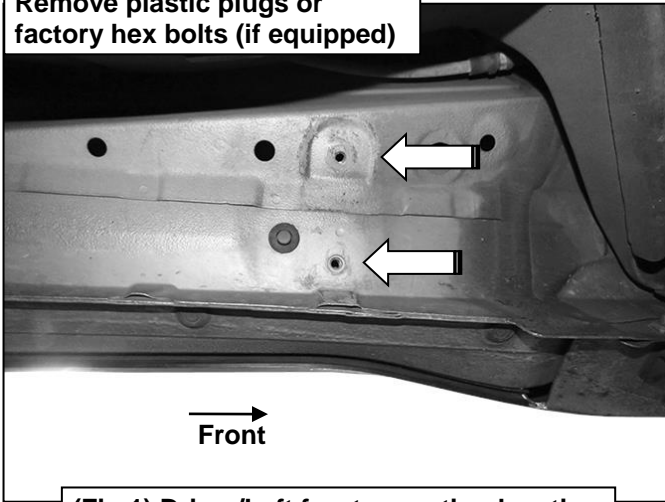

(Fig 1) Driver/Left front mounting location

(2) 8mm Hex Bolts
(2) 8mm Lock Washers
(2) 8mm Flat Washers

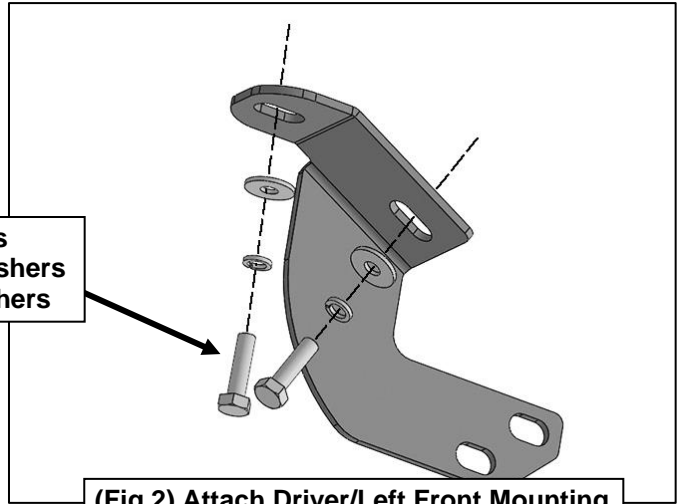

(Fig 2) Attach Driver/Left Front Mounting
Bracket to the floor panel

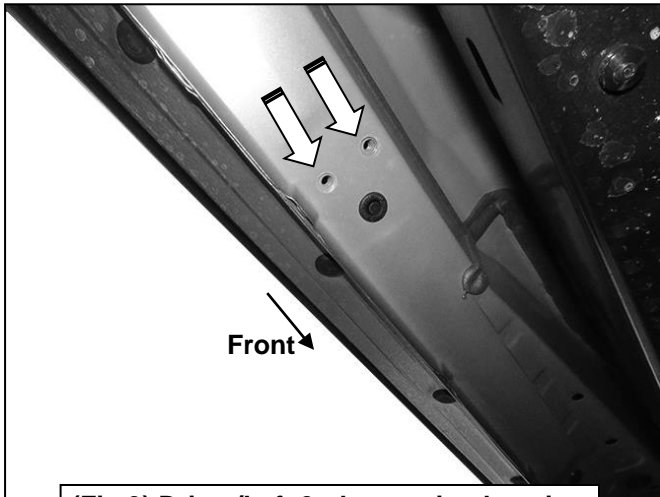

(Fig 3) Driver/Left 2nd mounting location

(2) 8mm Hex Bolts
(2) 8mm Lock Washers
(2) 8mm Flat Washers

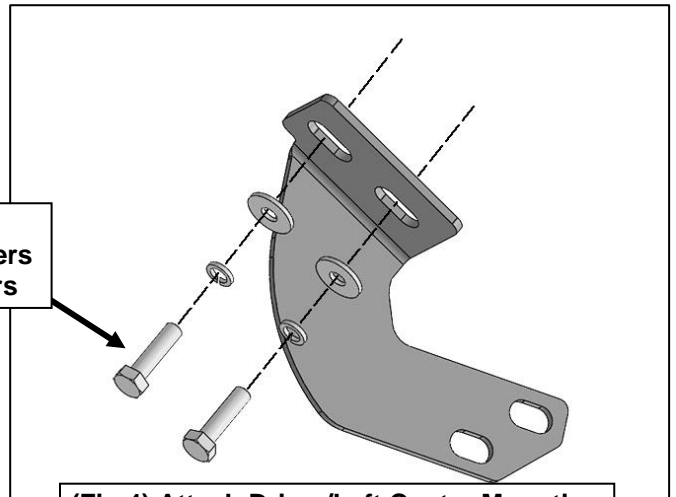

(Fig 4) Attach Driver/Left Center Mounting
Bracket to the floor panel

Driver/Left Side Installation Pictured

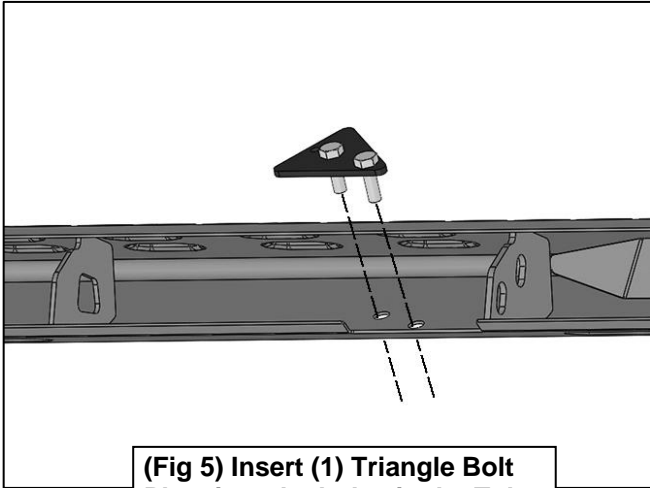

(Fig 5) Insert (1) Triangle Bolt Plate into the holes in the Tube

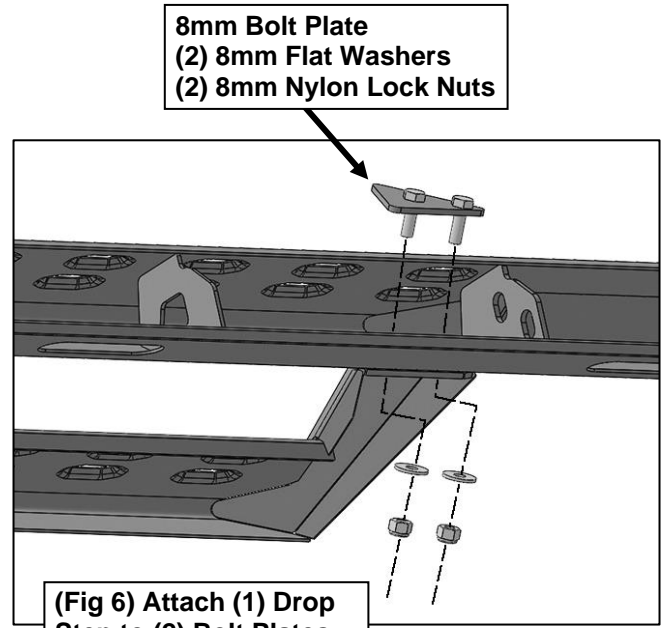

- 8mm Bolt Plate**
- (2) 8mm Flat Washers**
- (2) 8mm Nylon Lock Nuts**

(Fig 6) Attach (1) Drop Step to (2) Bolt Plates

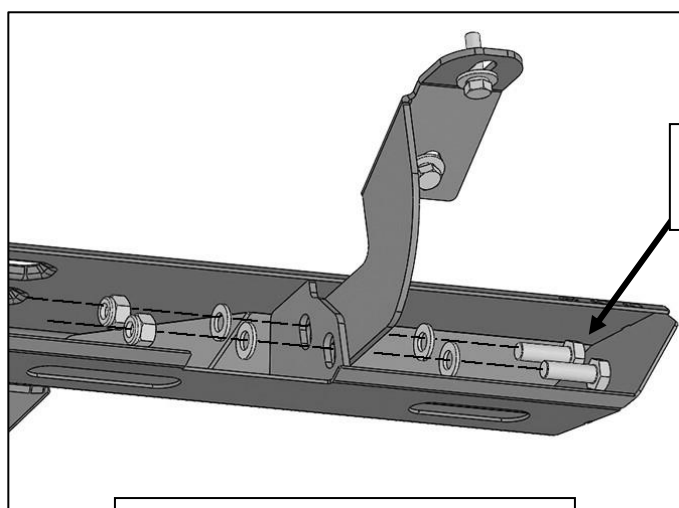

- (2) 10mm Hex Bolts**
- (4) 10mm Flat Washers**
- (2) 10mm Nylon Lock Nuts**

(Fig 7) Attach Driver/Left Overland Slider to the Mounting Brackets