

**PARTS LIST:**

1	Driver/Left Tube	24	10mm x 20mm OD x 2mm Flat Washers
1	Passenger/Right Tube	12	10mm Nylon Lock Nuts
4	Drop Steps	8	8mm x 25mm Triangle Double Bolt Plates
1	Driver/Left Front Mounting Bracket	12	8mm x 30mm Hex Bolts
1	Passenger/Right Front Mounting Bracket	12	8mm x 24mm OD x 2mm Flat Washers
2	Driver/Left Rear Mounting Brackets	16	8mm x 22mm OD x 2mm Flat Washers
2	Passenger/Right Rear Mounting Brackets	12	8mm Lock Washers
12	10mm x 30mm Hex Bolts	16	8mm Nylon Lock Nuts

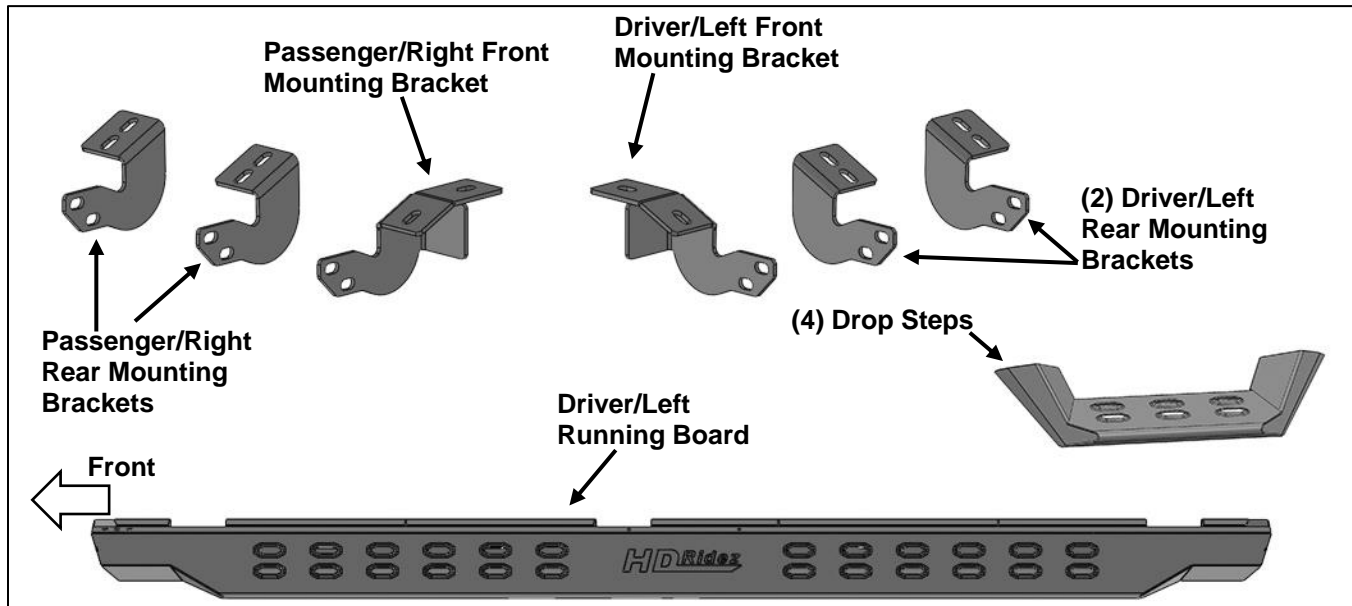

**PROCEDURE:**

- 1. REMOVE CONTENTS FROM BOX. VERIFY ALL PARTS ARE PRESENT. READ INSTRUCTIONS CAREFULLY. USE ILLUSTRATION TO IDENTIFY BRACKETS.**
- Starting on the Driver/Left front of the vehicle, remove the plastic plugs, (or hex bolts), covering the threaded holes in the body panel, **(Figure 1)**. Select the Driver/Left Front Mounting Bracket. Attach the Bracket to the vehicle with (2) 8mm Hex Bolts, (2) 8mm Lock Washers and (2) 8mm Flat Washers, **(Figure 2)**. Do not tighten hardware.
- Move along the body panel to the center mounting location. Select (1) Driver/Left Rear Mounting Bracket. Repeat **Step 2** to install the Mounting Bracket, **(Figures 3 & 4)**. Do not tighten hardware.
- Continue to the last mounting location at the back of the cab, **(Figure 5)**. Select the remaining (1) Driver/Left Rear Mounting Bracket. Repeat **Step 2** to attach the Bracket to the rear mounting location. Do not tighten hardware.
- Select the Driver/Left Tube. Insert (2) 8mm Triangle Double Bolt Plates into the front (2) sets of (2) holes, **(Figure 6)**. Attach (1) Drop Step to the (2) Double Bolt Plates with (4) 8mm x 22mm Flat Washers and (4) 8mm Nylon Lock Nuts, **(Figure 7)**. Do not tighten hardware.
- With assistance, line up the mounting tabs in the Driver/Left Tube to the rear faces of the Mounting Brackets. Secure the Tube to the Mounting Brackets with (6) 10mm Hex Bolts, (12) 10mm x 20mm Flat Washers and (6) 10mm Nylon Lock Nuts, **(Figure 8)**. Do not tighten hardware.
- Level and adjust the Overland Step, then tighten all hardware.
- Repeat **Steps 1—7** to attach the Passenger/Right Overland Step.
- Do periodic inspections to the installation to make sure that all hardware is secure and tight.

**To protect your investment,** Do not use any type of polish or wax that may contain abrasives that could damage the finish. Mild soap may be used to clean the Overland Steps.

### Driver Side Installation Pictured

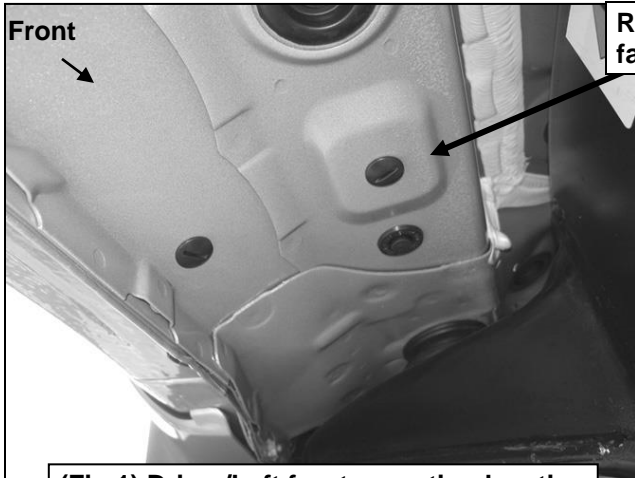

(Fig 1) Driver/Left front mounting location

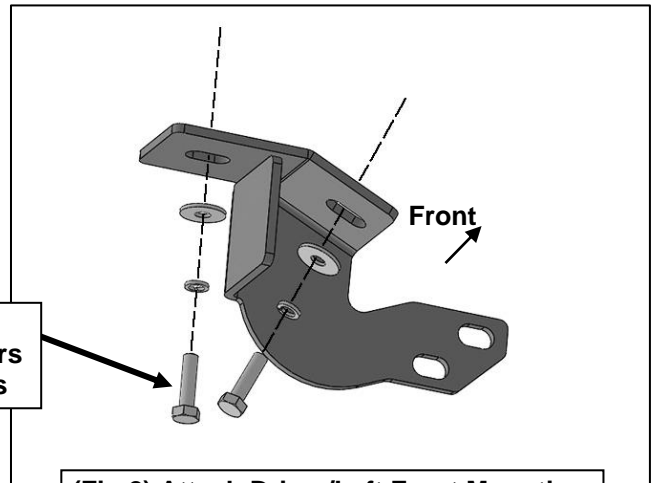

(Fig 2) Attach Driver/Left Front Mounting Bracket to the front mounting location

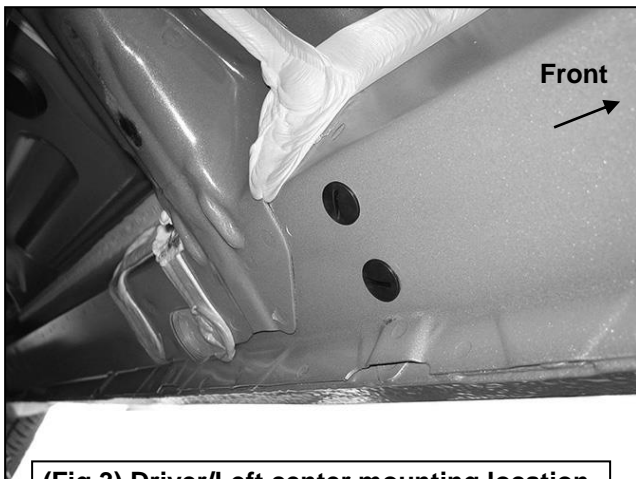

(Fig 3) Driver/Left center mounting location

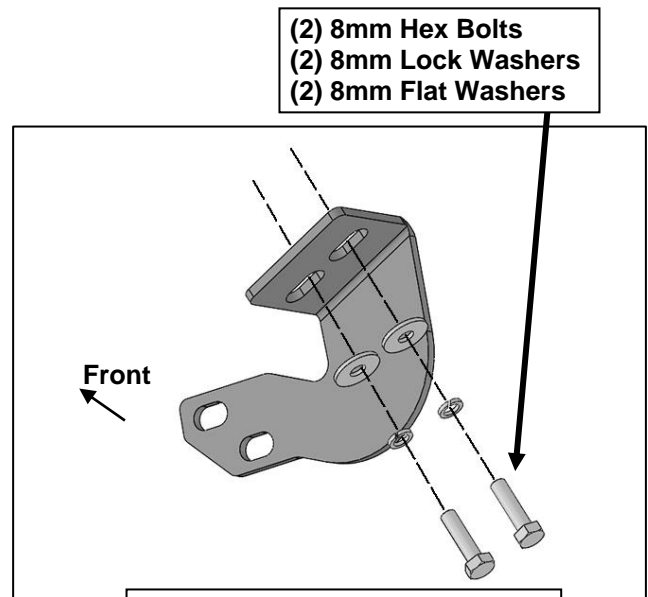

(Fig 4) Attach Driver/Left Rear Mounting Brackets to the center and rear mounting locations

### Driver Side Installation Pictured

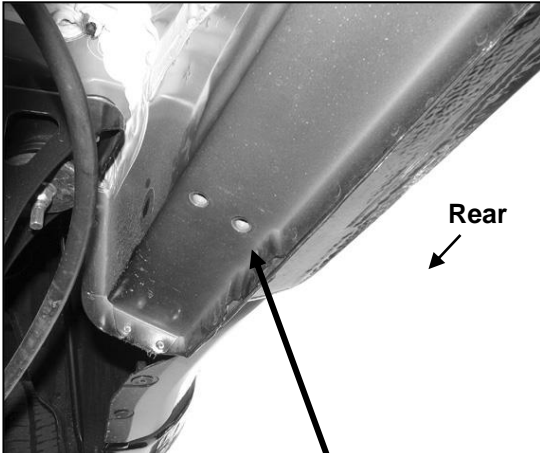

(Fig 5) Driver/Left rear mounting location

- 8mm Triangle Bolt Plate
- (2) 8mm Flat Washers
- (2) 8mm Nylon Lock Nuts

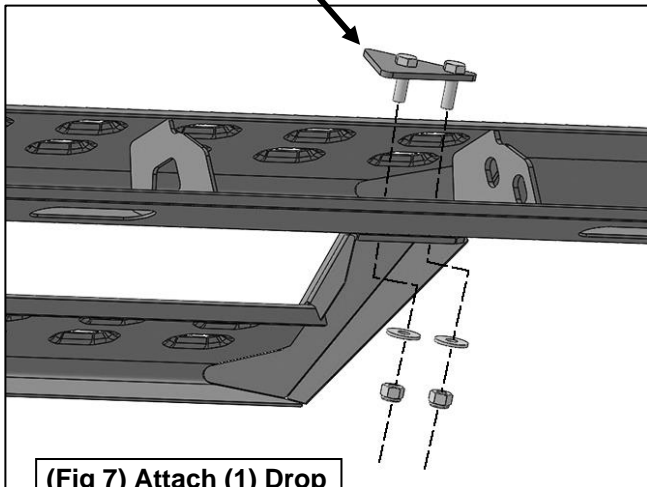

(Fig 7) Attach (1) Drop Step to (2) Bolt Plates

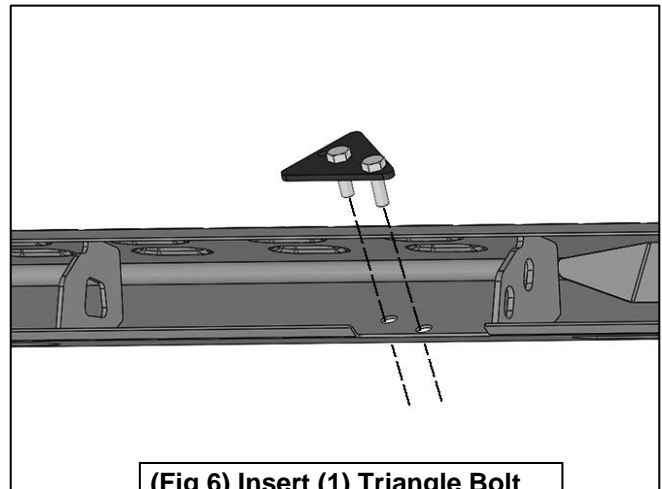

(Fig 6) Insert (1) Triangle Bolt Plate into the holes in the Tube

- (2) 10mm Hex Bolts
- (4) 10mm Flat Washers
- (2) 10mm Nylon Lock Nuts

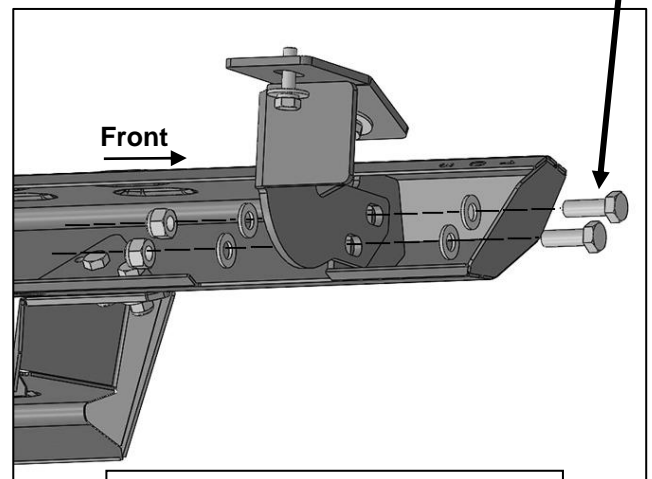

(Fig 8) Attach Driver/Left Running Board to the Mounting Brackets