

**PARTS LIST:**

1	Driver/Left side S6 Running Board	12	8mm x 30mm Hex Bolts
1	Passenger/Right side S6 Running Board	24	8mm x 24mm OD 2mm Flat Washers
3	Driver/Left side Mounting Brackets	18	8mm Nylon Lock Nuts
3	Passenger/Right side Mounting Brackets	12	8mm Lock Washers
6	8mm x 35mm Double Bolt Plates		

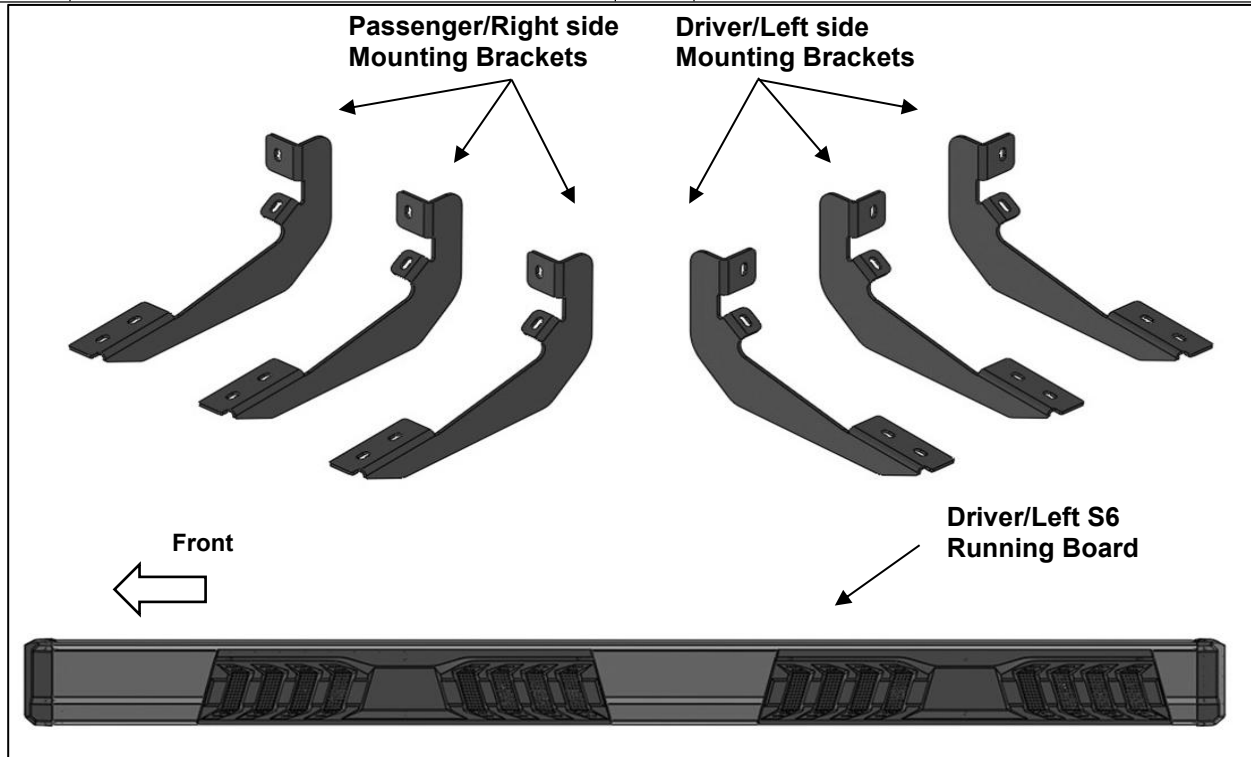

**PROCEDURE:**

**REMOVE CONTENTS FROM BOX. VERIFY ALL PARTS ARE PRESENT. READ INSTRUCTIONS CAREFULLY BEFORE STARTING INSTALLATION.**

1. Start installation at the front of the driver side of the vehicle and locate the factory threaded stud and the threaded hole located on the side of the inner body panel, **(Figure 1 & 2)**. There are (4) mounting locations along the body panel. Bracket installation will use the 1st, 2nd and 4th mounting locations.  
**NOTE:** Remove the plastic plug or any insulation on the side panel to locate the threaded holes.
2. Select (1) Driver/Left Mounting Bracket. Attach the Bracket to the mounting location with:
  - a. **Models with threaded stud:** Attach Bracket to stud with (1) 8mm x 24mm Flat Washer and (1) 8mm Nylon Lock Nut. Next, use (1) 8mm Hex Bolt, (1) 8mm Lock Washer and (1) 8mm x 24mm Flat Washer to attach the Bracket to the threaded insert hole on the body panel, **(Figure 3)**. Do not tighten hardware.
  - b. **Models without threaded stud, (Figure 2):** Attach Bracket to the upper threaded hole with (1) 8mm Hex Bolt, (1) 8mm Lock Washer and (1) 8mm x 24mm Flat Washer. Attach Bracket to the lower threaded hole with (1) 8mm Hex Bolt, (1) 8mm Lock Washer and (1) 8mm x 24mm Flat Washer, **(Figure 3)**. Do not tighten hardware.
3. Repeat **Steps 1 & 2** to install the center and rear Mounting Brackets.
4. Select the Driver/Left S6 Running Board. Select (3) Double Bolt Plates. Insert the Bolt Plates into the channel in the bottom of the Running Board closest to the Brackets, **(Figure 4)**. Lift the Running Board up and guide the studs through the Brackets. **IMPORTANT:** Do not slide, (front to back), the Running Board on the Brackets or damage to the finish may result.
5. Attach the Running Board to the Brackets with (6) 8mm x 24mm Flat Washers and (6) 8mm Nylon Lock Nuts, **(Figure 5)**. Do not tighten hardware.
6. Level and adjust the Running Board and tighten all hardware.

7. Repeat **Steps 1—6** to attach the Passenger/Right Running Board.
8. Do periodic inspections of the installation to make sure that all hardware is secure and tight.

**To protect your investment:** Do not use any type of polish or wax that may contain abrasives that could damage the finish. Mild soap may be used to clean the Running Board.

### Driver/Left Side Installation Pictured

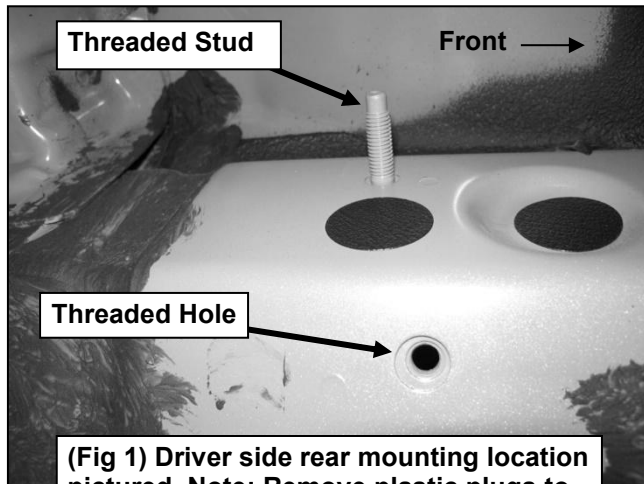

(Fig 1) Driver side rear mounting location pictured. Note: Remove plastic plugs to locate factory threaded holes

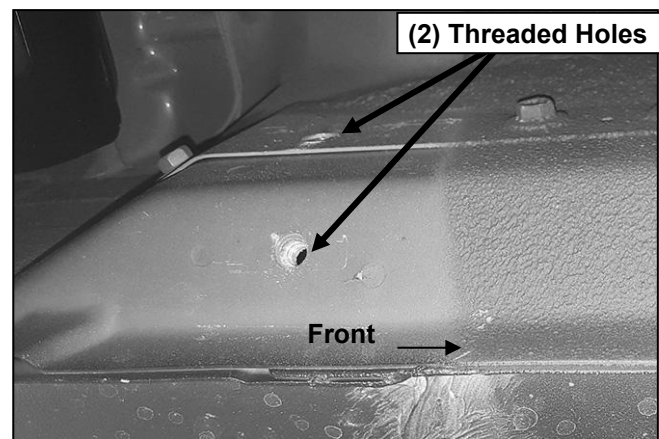

(Fig 2) 2016-on driver side rear mounting location pictured. Note: two factory threaded holes only

**Driver/Left Side Installation Pictured**

- 8mm x 30mm Hex Bolt
- 8mm Lock Washer
- 8mm x 24mm Flat Washer
- Or
- 8mm x 24mm Flat Washer
- 8mm Nylon Lock Nut

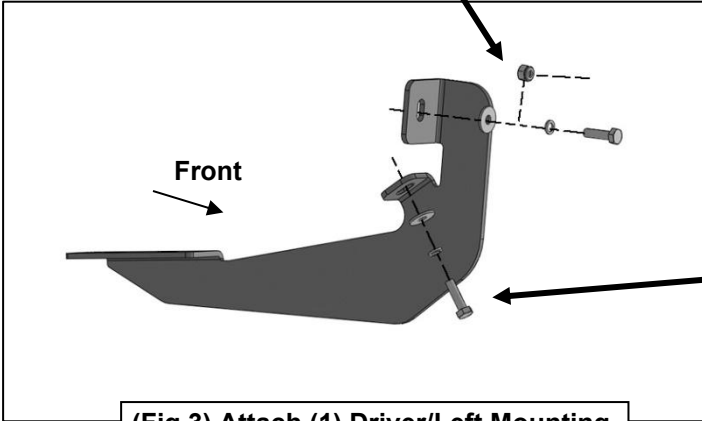

**NOTE:** For models with threaded studs, use the Nylon Lock Nuts. For models with threaded holes, use the Hex Bolts and Lock Washers

- 8mm x 30mm Hex Bolt
- 8mm Lock Washer
- 8mm x 24mm Flat Washer

**(Fig 3) Attach (1) Driver/Left Mounting Bracket to the front location**

**8mm Double Bolt Plate**

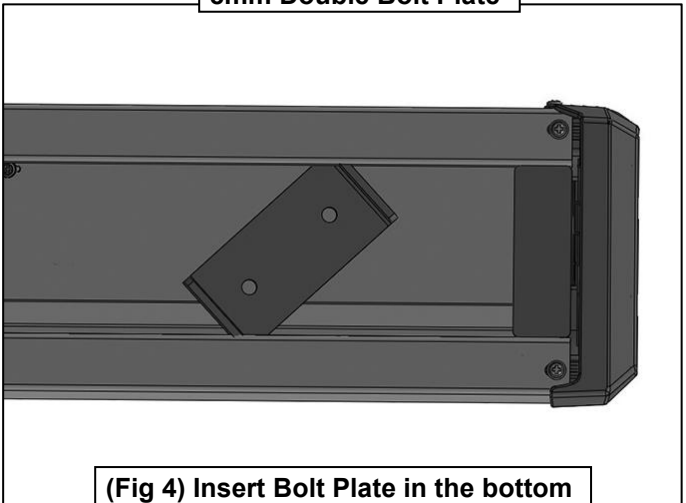

**(Fig 4) Insert Bolt Plate in the bottom of the channel on the Running Board**

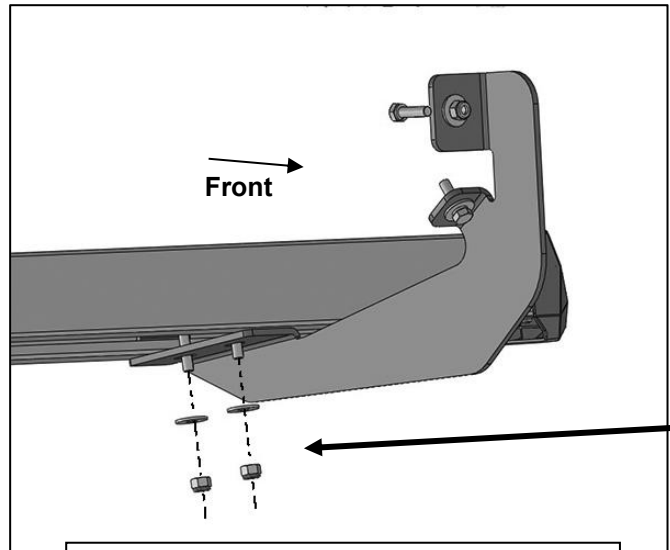

- (2) 8mm x 24mm Flat Washers
- (2) 8mm Nylon Lock Nuts

**(Fig 5) Attach the Driver/Left S6 Running Board to the Mounting Brackets**