

PARTS LIST:

1	Driver/Left S6 Running Board	3	10mm Lock Washers
1	Passenger/Right S6 Running Board	3	10mm x 30mm OD x 2.5mm Flat Washers
1	Driver/Left Front Mounting Bracket	1	10mm x 27mm OD x 3mm Flat Washer
1	Passenger/Right Front Mounting Bracket	1	10mm Hex Nut
1	Driver/Left Center Mounting Bracket	1	10mm Threaded Insert
1	Passenger/Right Center Mounting Bracket	1	10mm Insert Tool
1	Driver/Left Rear Mounting Bracket	6	8mm x 35mm Double Bolt Plates
1	Passenger/Right Rear Mounting Bracket	12	8mm x 24mm OD x 2mm Flat Washers
3	12mm x 50mm Hex Bolts	12	8mm Nylon Lock Nuts
3	12mm Lock Washers	6	6mm x 30mm Hex Bolts
3	12mm x 32mm OD x 3mm Flat Washers	12	6mm x 18mm OD x 1.6mm Flat Washers
3	10mm x 50mm Hex Bolts	6	6mm Lock Washers
1	10mm x 40mm Hex Bolt	6	6mm Hex Nuts

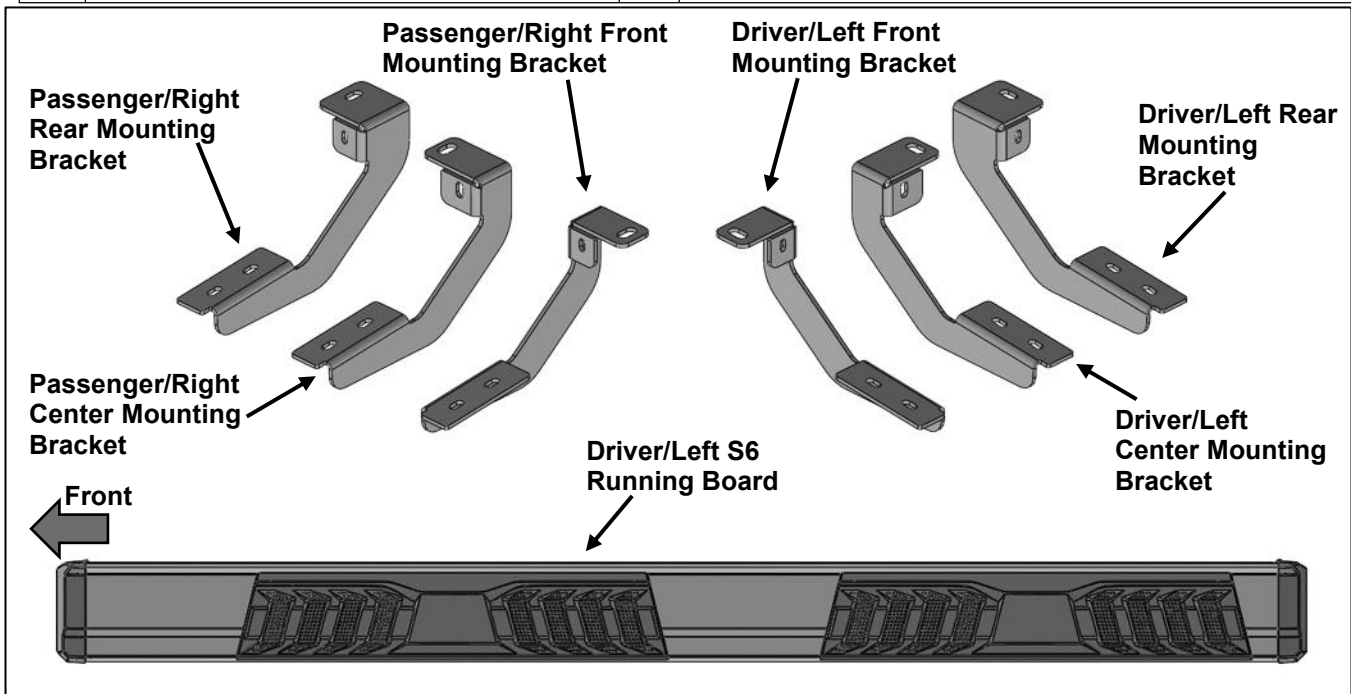

PROCEDURE:

- 1. REMOVE CONTENTS FROM BOX. VERIFY ALL PARTS ARE PRESENT. READ INSTRUCTIONS CAREFULLY. USE ILLUSTRATION TO IDENTIFY BRACKETS AND SIDEBARS.**
- Starting on the Driver/Left front of the vehicle, remove the cover on the bottom of the vehicle. Select the Driver/Left Front Mounting Bracket. Attach the Mounting Bracket to the threaded insert in the front location with (1) 12mm Hex Bolt, (1) 12mm Lock Washer and (1) 12mm Flat Washer, **(Figures 1 & 2)**. Do not tighten hardware.
- Attach the Mounting Bracket to the pinch trim with (1) 6mm Hex Bolts, (2) 6mm Flat Washers, (1) 6mm Lock Washers and (1) 6mm Hex Nut, **(Figure 3)**. Do not tighten hardware.
- Move along the body panel to the center mounting location, **(Figure 4)**. Select the Driver/Left Center Mounting Bracket. Repeat **Step 2** to install the Bracket, **(Figures 3 & 4)**. Do not tighten hardware.
- Continue to the rear mounting location in front of the rear tire, **(Figure 5)**. Select the Driver/Left Rear Mounting Bracket. Attach the Bracket to the threaded insert with (1) 10mm Hex Bolt, (1) 10mm Lock Washer and (1) 10mm Flat Washer, **(Figures 5 & 6)**. Do not tighten hardware. Repeat **Step 3** to attach the Bracket to the pinch trim.
- Unwrap the Driver/Left S6 Running Board. Select (3) 8mm Double Bolt Plates, **(Figure 7)**. Insert the Bolt Plates into the channel in the bottom of the Running Board.
- Place the Running Board on top of the (3) Mounting Brackets. Lift the Running Board up and guide the studs down through the Brackets. **IMPORTANT:** Do not slide the Running Board on the Brackets, (front to back or rotate), or the finish on the Running Board may be damaged.

8. Attach the Running Board to the Brackets with (6) 8mm Flat Washers and (6) 8mm Nylon Lock Nuts, **(Figure 8)**. Do not tighten hardware.
9. Level and adjust the S6 Running Board and tighten all hardware.
10. Move to the Passenger/Right side. Repeat **Steps 1,2 & 5** to attach the Passenger/Right Front and Rear Mounting Brackets.
11. Locate the center mounting location, **(Figure 9)**. Select the Passenger/Right Center Mounting Bracket. Hold the Bracket and line up to the hole in the pinch trim to the lower slot in the top of the Bracket. Mark where the top slot is located on the floor panel. Using a 1/2" drill bit, (not included) to drill through only the bottom layer of the floor panel.
12. Select the 10mm Threaded Insert and the 10mm Insert Tool. Push the Tool and Insert assembly into the factory hole. **NOTE:** If Insert fits too tight, lightly tap it into place with a small hammer.
13. Firmly hold the handle on the Tool and tighten the hex bolt in the Insert until it is fully collapsed and locked in place, **(Figures 10 & 11)**. **NOTE:** Do not over tighten the Insert or a pull out may occur. Once Insert is collapsed, remove the tool from the Insert.
14. Attach the Passenger/Right Center Mounting Bracket to the Threaded insert with (1) 10mm Hex Bolt, (1) 10mm Lock Washer and (1) 10mm Flat Washer. Do not tighten hardware. Repeat **Step 3** to attach the Bracket to the pinch trim.
15. Repeat **Steps 6—9** to attach the Passenger/Right S6 Running Board. Do not tighten hardware.
16. Level and adjust the Running Board and tighten all hardware.
17. Do periodic inspections to the installation to make sure that all hardware is secure and tight.

To protect your investment, Do not use any type of polish or wax that may contain abrasives that could damage the finish. Mild soap may be used to clean the Running Boards.

Driver Side Installation Pictured

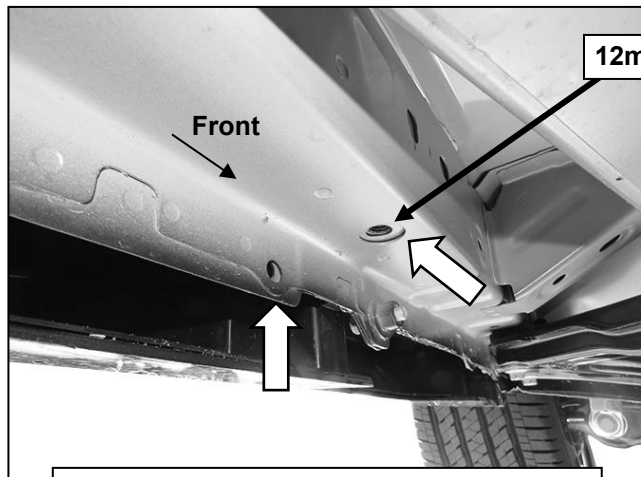

(Fig 1) Driver/Left front mounting location

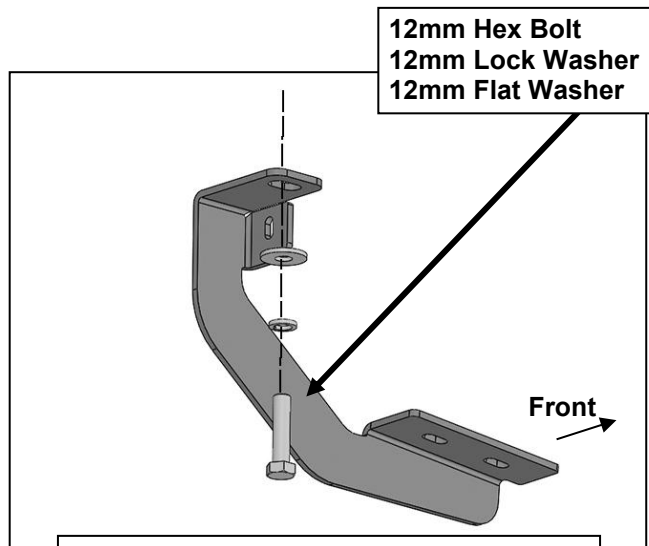

(Fig 2) Attach Driver/Left Front Mounting Bracket to the front mounting location

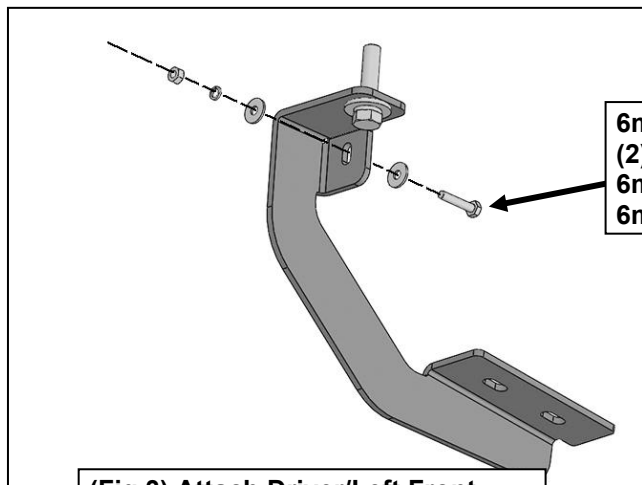

(Fig 3) Attach Driver/Left Front Mounting Bracket to the pinch trim

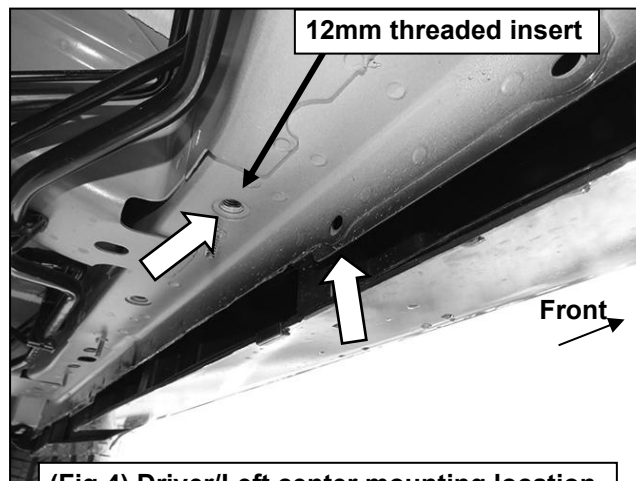

(Fig 4) Driver/Left center mounting location

Driver Side Installation Pictured

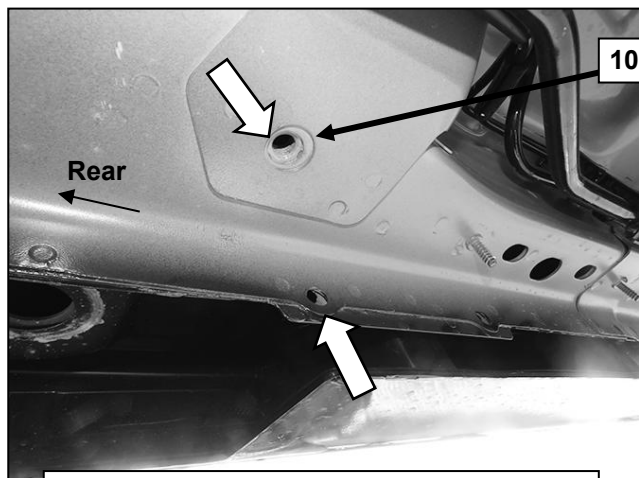

(Fig 5) Driver/Left rear mounting location. The threaded insert is smaller than the front and center locations

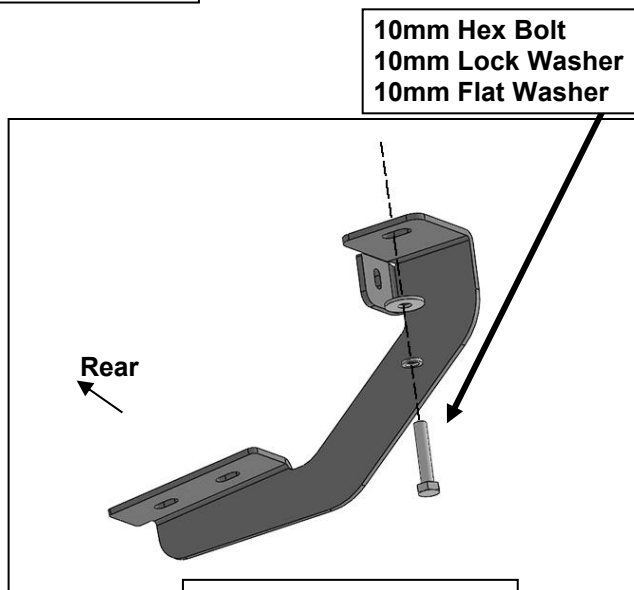

(Fig 6) Attach Driver/Left Rear Mounting Bracket

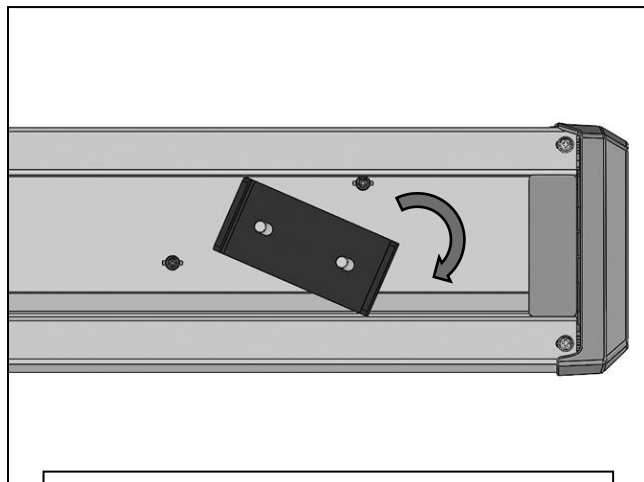

(Fig 7) Insert 8mm Double Bolt Plates into tracks on the bottom of the Running Board

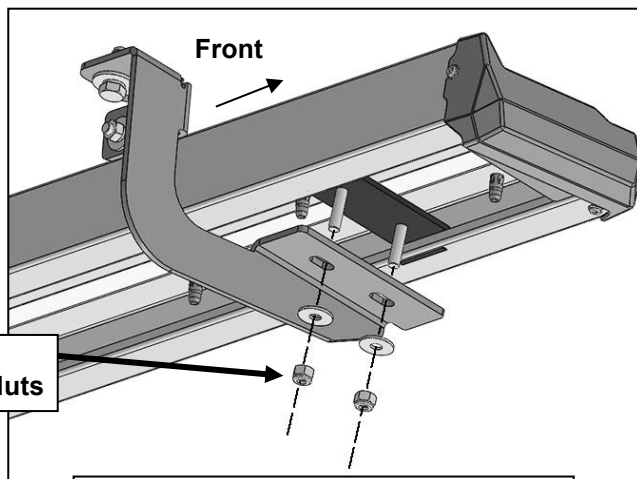

(Fig 8) Attach the Driver/Left Running Board to the Bolt Plate

Passenger Side Installation Pictured

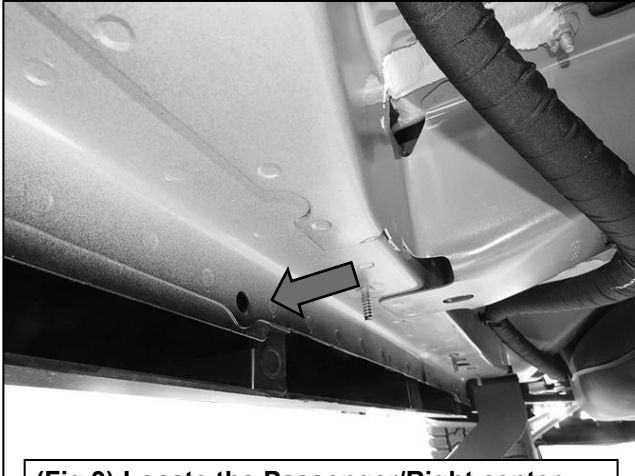

(Fig 9) Locate the Passenger/Right center mounting location. Line up the top of the Passenger/Right Center Mounting Bracket to the hole in the pinch trim. Mark the top slot for drilling. Use a 1/2" drill bit, not included

(10-A) Select Insert Tool and (1) Insert. Thread Insert onto end of Insert Tool. Hand tighten only, do not tighten hex bolt

(10-B) Firmly hold assembly and push Insert into drilled hole.

(10-C) Hold Tool Assembly up tight in body panel. Turn hex bolt in Tool clockwise to expand insert in body panel. Remove Tool once Insert is fully tightened. Do not overtighten or Insert may be damaged.

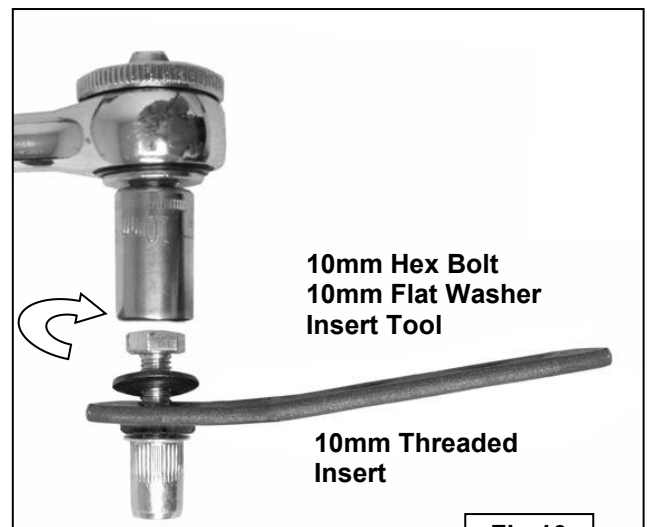

Fig 10



(Fig 11) Threaded Insert installed in the floor panel