

INSTALLATION INSTRUCTIONS

S6 RUNNING BOARD

2018-2023 Jeep Wrangler JL 2DR

PART#WB-JS116BD

Parts List:

2	S6 Running Board	4	10mm Nylon Lock Nuts
1	Driver/Left Front Mounting Bracket	4	8mm x 35mm Double Bolt Plates
1	Passenger/Right Front Mounting Bracket	4	8mm x 35mm Hex Bolts
1	Driver/Left Rear Mounting Bracket	4	8mm x 28mm OD x 3mm Flat Washers
1	Passenger/Right Rear Mounting Bracket	8	8mm x 24mm OD x 2mm Flat Washers
1	Driver/Left Front Support Bracket	8	8mm Nylon Lock Nuts
1	Passenger/Right Front Support Bracket	4	8mm Lock Washers
1	Driver/Left Rear Support Bracket	8	6mm x 25mm Hex Bolts
1	Passenger/Right Rear Support Bracket	16	6mm x 22mm OD x 2mm Flat Washers
4	10mm x 30mm Hex Bolts	8	6mm Nylon Lock Nuts
8	10mm x 24mm OD x 2.2m Flat Washers		

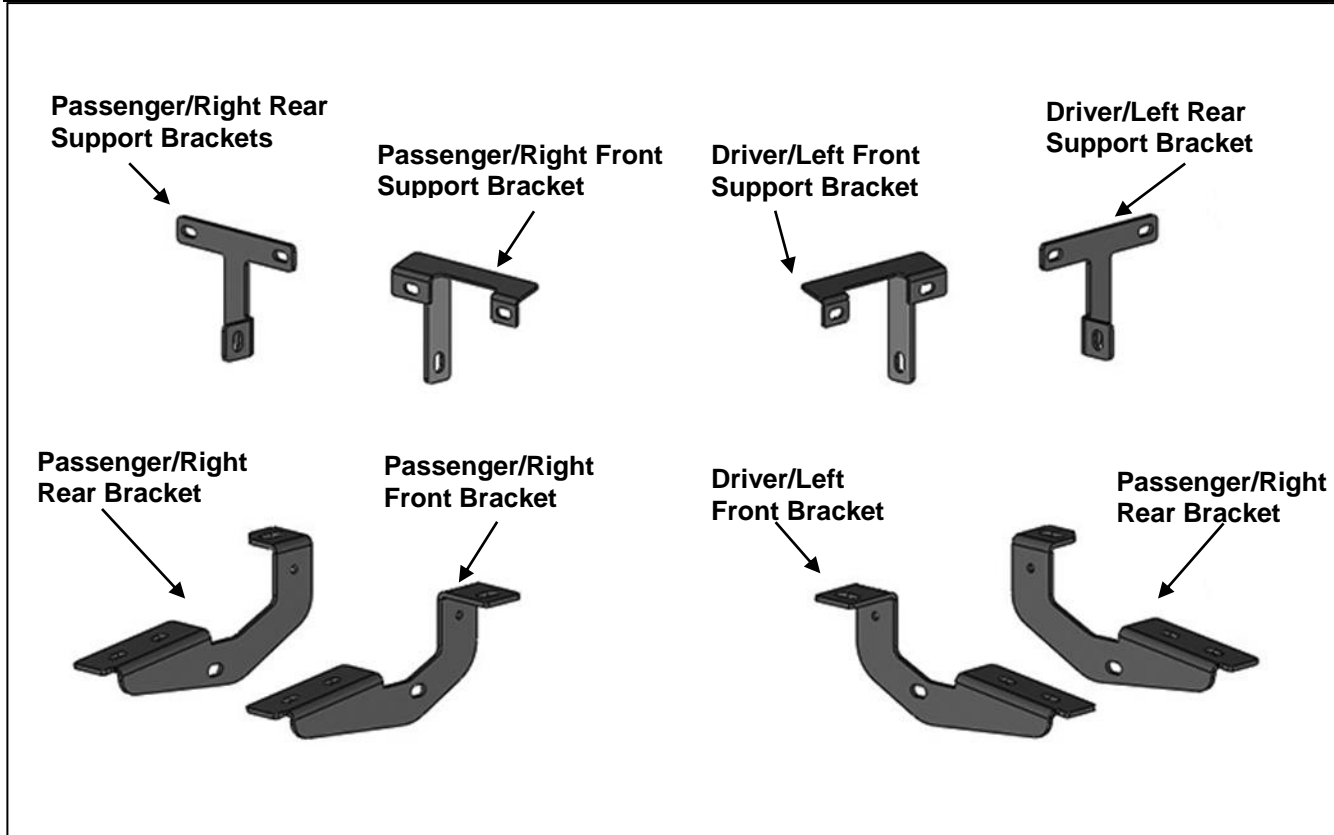

PROCEDURE:

1. REMOVE CONTENTS FROM BOX. VERIFY ALL PARTS ARE PRESENT. READ INSTRUCTIONS CAREFULLY BEFORE STARTING INSTALLATION. SIDE STEPS OR RUNNING BOARDS MUST BE REMOVED BEFORE INSTALLATION.
2. Start installation on the Passenger/Right front of the of the vehicle. Find the front threaded insert located in between the first pair of holes along the pinch weld, **(Figure 1)**.
3. Select the Passenger/Right Front Mounting Bracket. Attach the Mounting Bracket to the threaded insert using (1) 8mm Hex Bolt, (1) 8mm Lock Washer and (1) 8mm x 28mm Flat Washer, **(Figure 2)**. Do not tighten hardware.
4. Select the Passenger/Right Front Support Bracket. Attach the Support Bracket to the pinch weld using (2) 6mm Hex Bolts, (4) 6mm Flat Washers and (2) 6mm Nylon Lock Nuts, **(Figure 3)**. **NOTE: Insert Bolts from the outside of the pinch weld.** Attach the Support Bracket to the Mounting Bracket with (1) 10mm Hex Bolt, (2) 10mm Flat Washers and (1) 10mm Nylon Lock Nut, **(Figure 4)**. Do not tighten hardware.
5. Move to the rear mounting location on the rocker panel and locate the threaded insert and pair of holes in the pinch weld, **(Figure 5)**. Repeat **Steps 3 & 4** to attach the Passenger/Right Rear Mounting Bracket and (1) Rear Support Bracket. Do not tighten hardware.

6. Select (1) S6 Running Board. Select (2) Double Bolt Plates. Insert the Bolt Plates into the channel in the bottom of the Running Board closest to the Brackets, **(Figure 6)**. Lift the Running Board up and guide the studs through the Brackets. **IMPORTANT:** Do not slide, (front to back), the Running Board on the Brackets or damage to the finish may result.
7. Carefully place Running Board onto the Mounting Brackets. Attach the Running Board to the Mounting Brackets with (4) 8mm x 24mm Flat Washers and (4) 8mm Nylon Lock Nuts, **(Figure 7)**. Do not tighten hardware.
8. Level and adjust the S6 Running Board and tighten all hardware.
9. Repeat **Steps 1—8** for the other S6 Running Board installation.
10. Do periodic inspections to the installation to make sure that all hardware is secure and tight.

To protect your investment, Do not use any type of polish or wax that may contain abrasives that could damage the finish. Mild soap may be used to clean Running Boards.

Passenger/Right Side Installation Pictured

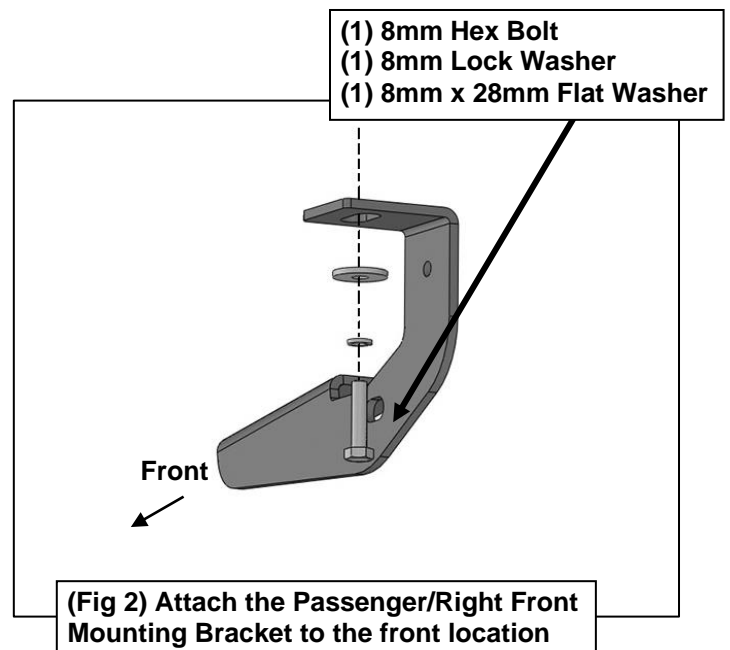
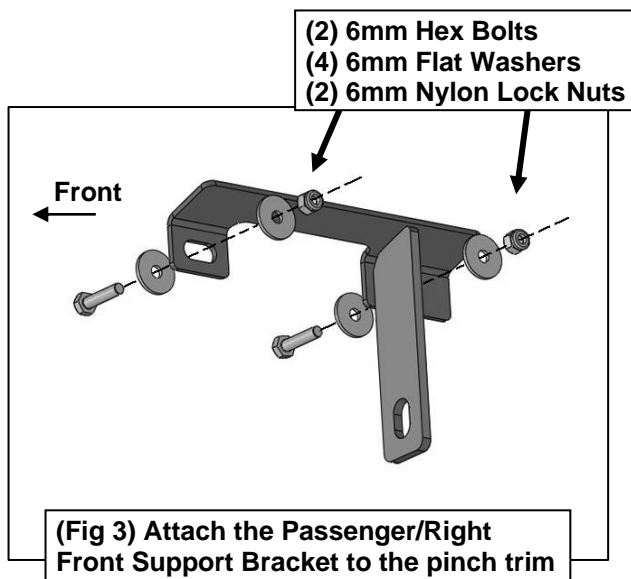
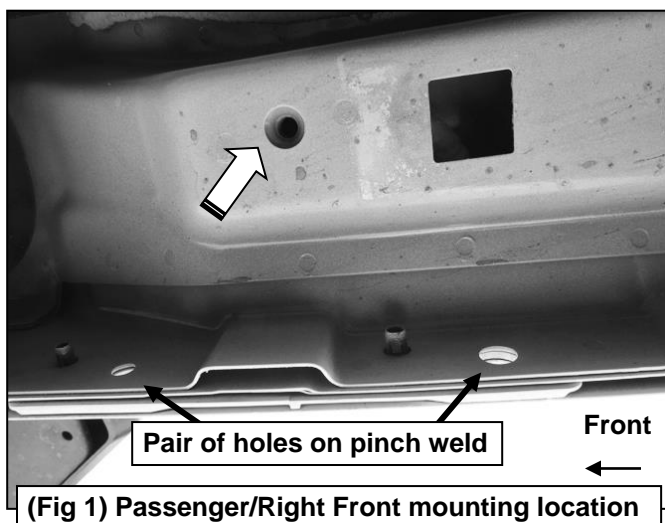

Passenger/Right Side Installation Pictured

- (1) 10mm Hex Bolt
- (2) 10mm Flat Washers
- (1) 10mm Nylon Lock Nut

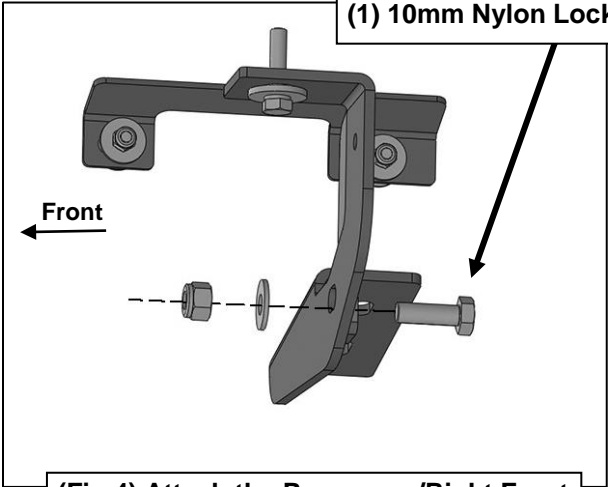

(Fig 4) Attach the Passenger/Right Front Support Bracket to the pinch weld

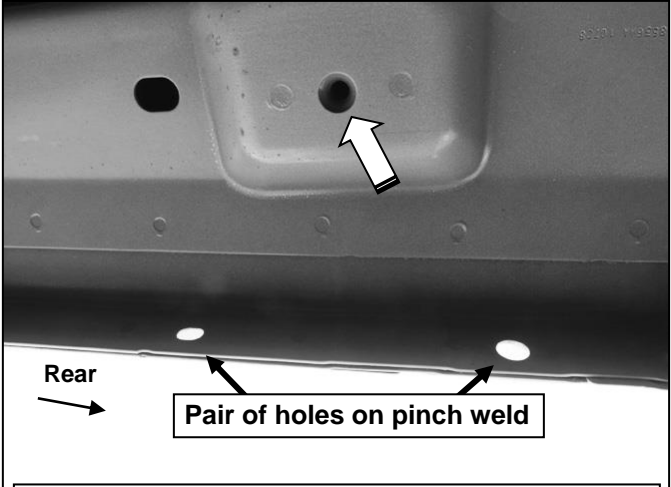

(Fig 5) Passenger/Right Rear mounting location

8mm Double Bolt Plate

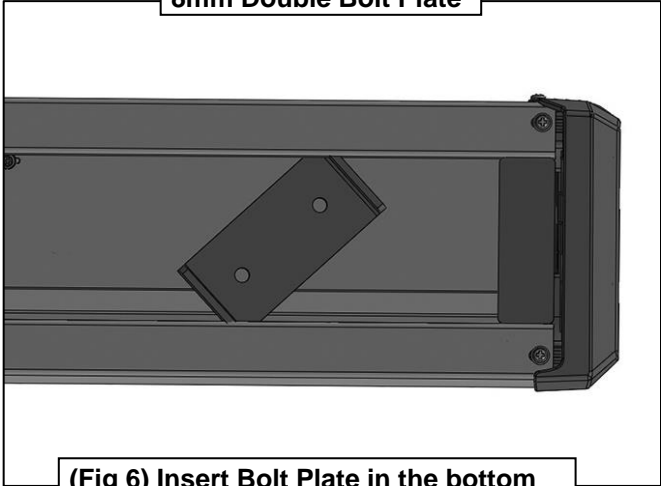

(Fig 6) Insert Bolt Plate in the bottom of the channel on the Running Board

- (4) 8mm x 24mm Flat Washers
- (4) 8mm Nylon Lock Nuts

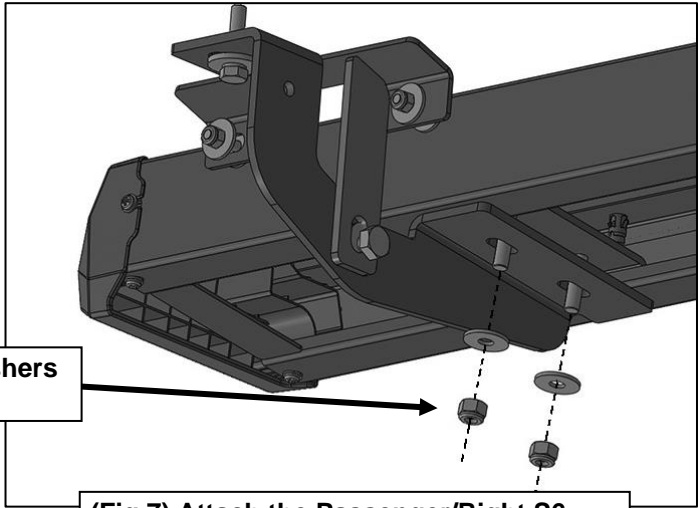

(Fig 7) Attach the Passenger/Right S6 Running Board to the Mounting Brackets