

**PARTS LIST:**

1	Driver/Left Tube	36	10mm x 20mm OD x 2mm Flat Washers
1	Passenger/Right Tube	6	10mm Lock Washers
4	Drop Steps	18	10mm Nylon Lock Nuts
1	Driver/Left Front Mounting Bracket	6	10mm Nut Plates
1	Passenger/Right Front Mounting Bracket	8	8mm Triangle Double Bolt Plates
1	Driver/Left Center Mounting Bracket	6	8mm x 35mm Hex Bolts
1	Passenger/Right Center Mounting Bracket	6	8mm x 28mm OD x 3mm Flat Washers
1	Driver/Left Rear Mounting Bracket	16	8mm x 22mm OD x 2mm Flat Washers
1	Passenger/Right Rear Mounting Bracket	6	8mm Lock Washers
3	Driver/Left Support Brackets	16	8mm Nylon Lock Nuts
3	Passenger/Right Support Brackets	12	6mm x 25mm Hex Bolts
6	10mm x 35mm Hex Bolts	24	6mm x 22mm OD x 2mm Flat Washers
18	10mm x 30mm Hex Bolts	12	6mm Nylon Lock Nuts
6	10mm x 34mm OD x 3mm Flat Washers		

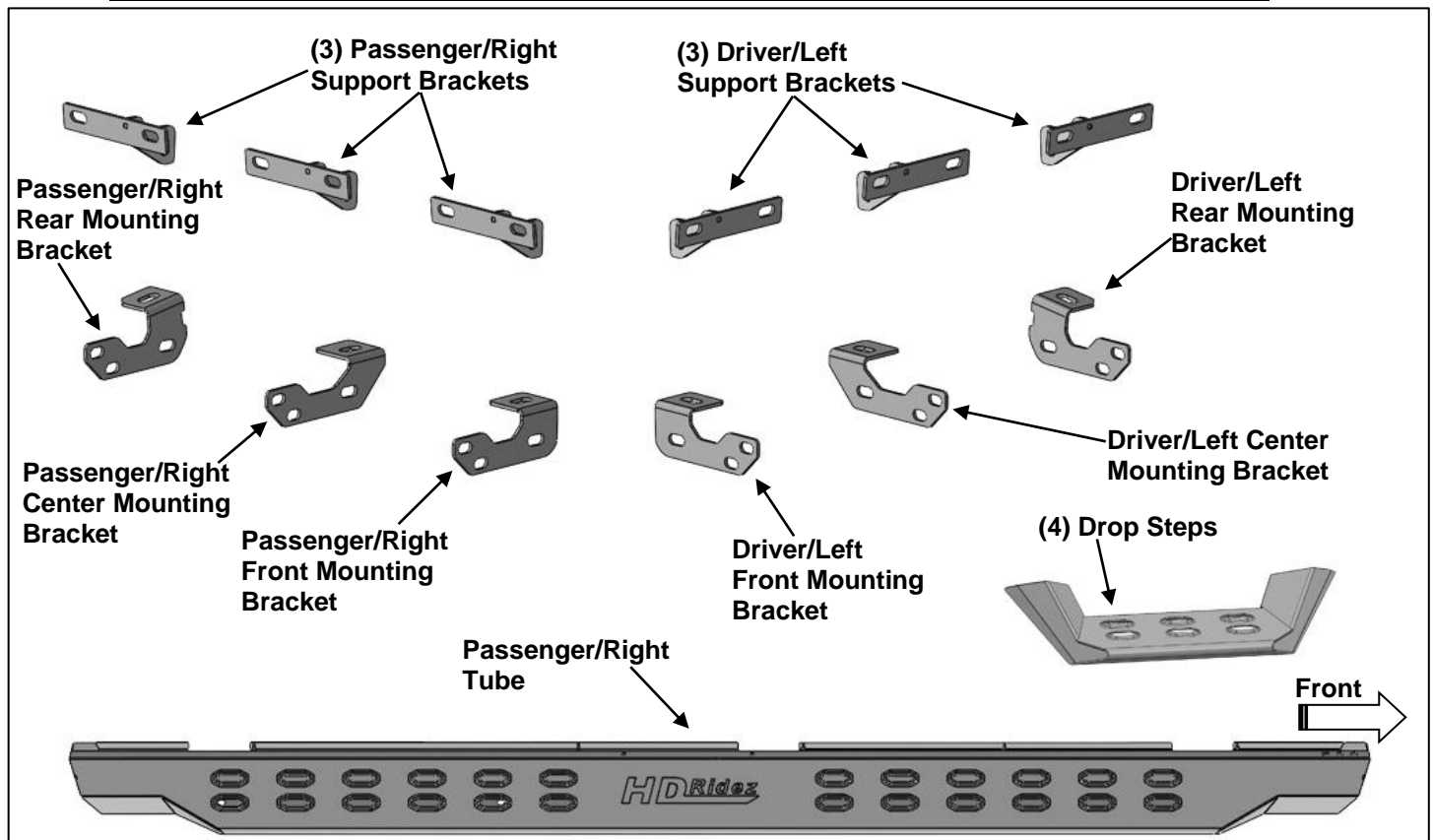

**PROCEDURE:**

1. REMOVE CONTENTS FROM BOX. VERIFY ALL PARTS ARE PRESENT. READ INSTRUCTIONS CAREFULLY. FACTORY INSTALLED OR AFTERMARKET PRODUCT MUST BE REMOVED.
2. Start installation toward the front of the Passenger/Right side of the vehicle, (Figure 1).
3. Determine if vehicle is equipped with threaded mounting inserts  
**Vehicles without threaded inserts:**
  - a. Insert (1) 10mm Nut Plate into the large square opening in the floor panel. Line up the threaded nut with the hole in between the pair of holes on the pinch weld, (Figures 2A & 2B).
  - b. Select the Passenger/Right Front Mounting Bracket.
  - c. Attach the Bracket to the Nut Plate with (1) 10mm x 35mm Hex Bolt, (1) 10mm Lock Washer and (1) 10mm x 34mm Flat Washer, (Figure 3). Do not tighten hardware.

**Vehicles with factory threaded hole in floor panel:**

- a. Locate the front, center and rear mounting locations, **(Figure 1)**.
- b. Select the Passenger/Right Front Mounting Bracket.
- c. Attach the Bracket to the front mounting location with (1) 8mm Hex Bolt, (1) 8mm Lock Washer and (1) 8mm Flat Washer, **(Figure 4)**. Do not tighten hardware.
4. Select (1) Passenger/Right Support Bracket. Attach the Support Bracket to the pinch weld with (2) 6mm Hex Bolts, (4) 6mm Flat Washers and (2) 6mm Nylon Lock Nuts, **(Figure 5)**. Attach the Support Bracket to the Mounting Bracket with (1) 10mm x 30mm Hex Bolt, (2) 10mm x 20mm Flat Washers and (1) 10mm Nylon Lock Nuts, **(Figure 6)**. Do not tighten hardware.
5. Repeat **Steps 3 & 4** to attach the Passenger/Right Mounting Brackets and Support Brackets to the center and rear locations, **(Figures 7A, 7B & 8)**. Do not tighten hardware.
6. Select the Passenger/Right Tube. Insert (2) 8mm Triangle Double Bolt Plates into the front (2) sets of (2) holes, **(Figure 9)**. Attach (1) Drop Step to the (2) Double Bolt Plates with (4) 8mm x 22mm Flat Washers and (4) 8mm Nylon Lock Nuts, **(Figure 10)**. Do not tighten hardware.
7. With assistance, line up the mounting tabs in the Passenger/Right Tube to the rear faces of the Mounting Brackets. Secure the Tube to the Mounting Brackets with (6) 10mm Hex Bolts, (12) 10mm x 20mm Flat Washers and (6) 10mm Nylon Lock Nuts, **(Figure 11)**. Do not tighten hardware.
8. Level and adjust the Overland Step, then tighten all hardware.
9. Repeat **Steps 1—8** to attach the Driver/Left Overland Slider.
10. Do periodic inspections to the installation to make sure that all hardware is secure and tight.

**To protect your investment,** Do not use any type of polish or wax that may contain abrasives that could damage the finish. Mild soap may be used to clean the Overland Sliders.

**Passenger/Right Side Installation Pictured**

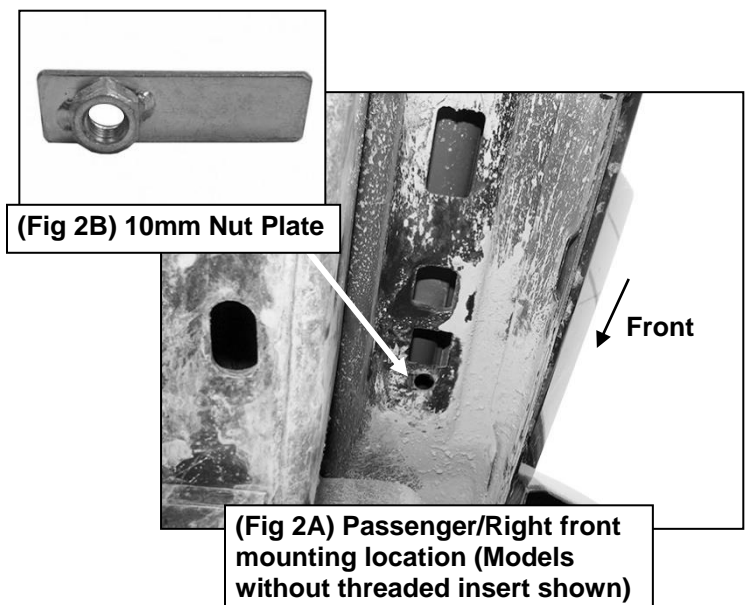
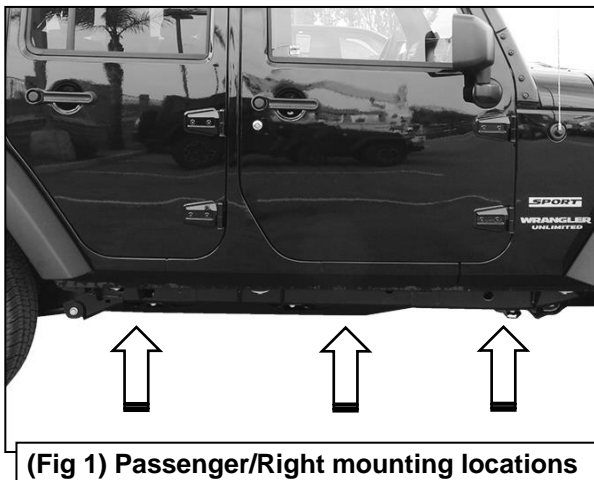

### Passenger/Right Side Installation Pictured

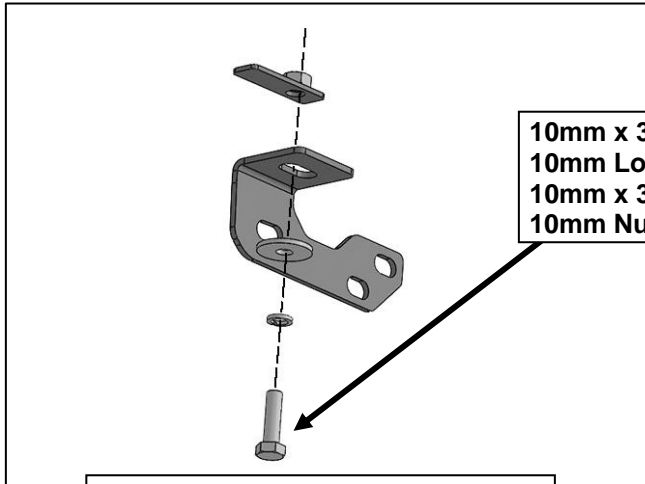

- 10mm x 35mm Hex Bolt
- 10mm Lock Washer
- 10mm x 34mm Flat Washer
- 10mm Nut Plate

(Fig 3) Attach the Passenger/Right Front Mounting Bracket to the Nut Plate in the front location

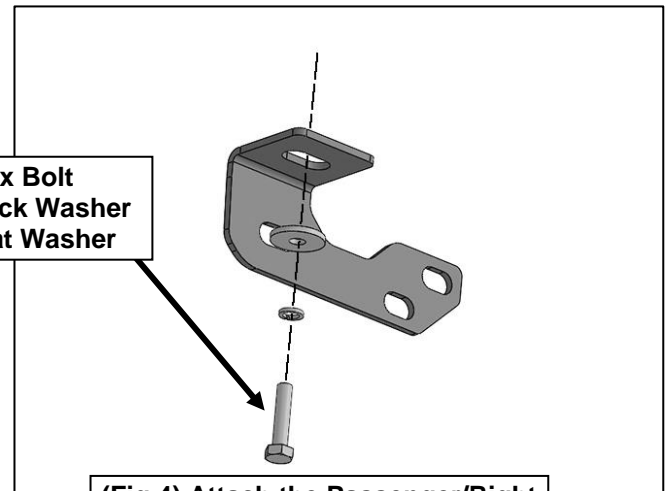

- 8mm Hex Bolt
- 8mm Lock Washer
- 8mm Flat Washer

(Fig 4) Attach the Passenger/Right Front Mounting Bracket to the threaded hole in the front location

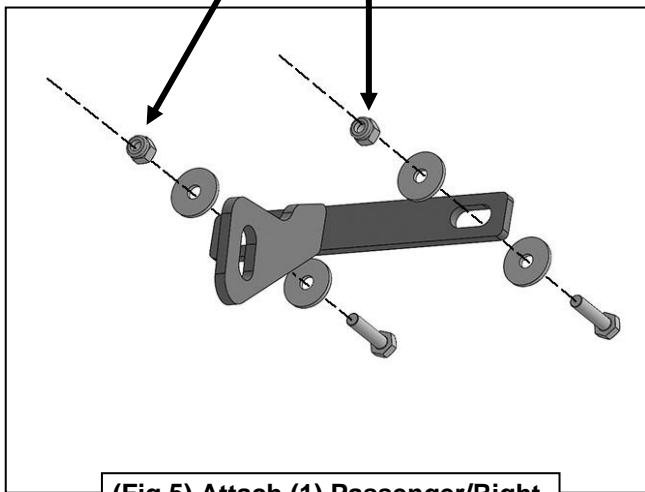

- (2) 6mm Hex Bolts
- (4) 6mm Flat Washers
- (2) 6mm Nylon Lock Nuts

(Fig 5) Attach (1) Passenger/Right Support Bracket to the (2) holes in the pinch trim in the front location

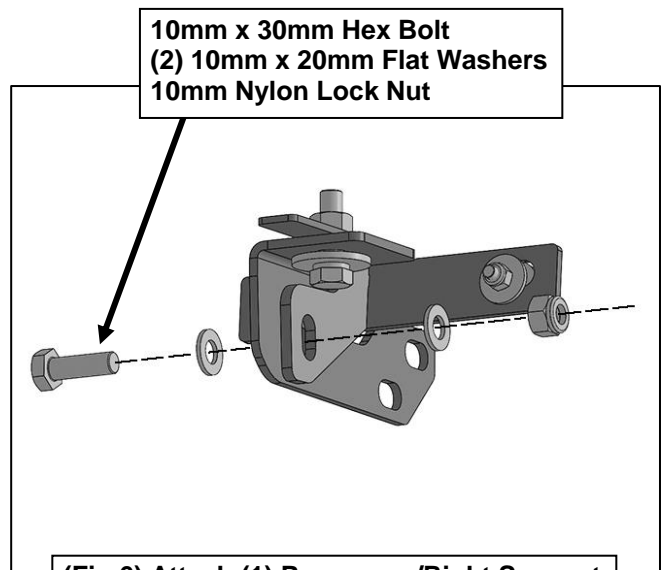

- 10mm x 30mm Hex Bolt
- (2) 10mm x 20mm Flat Washers
- 10mm Nylon Lock Nut

(Fig 6) Attach (1) Passenger/Right Support Bracket to the Front Mounting Bracket

### Passenger/Right Side Installation Pictured

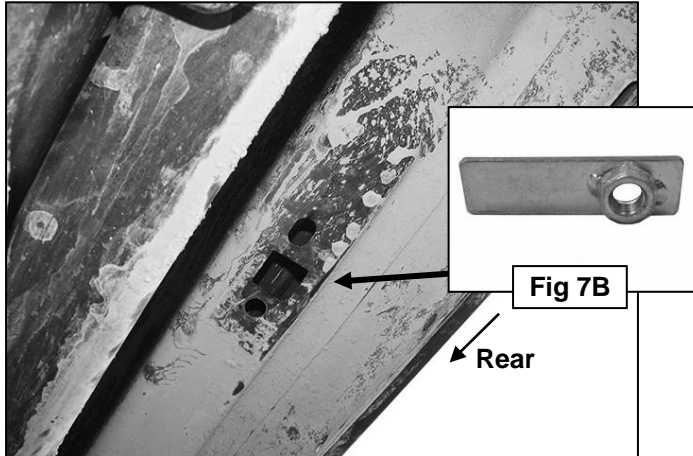

(Fig 7A) Passenger/Right center mounting location (Model without threaded insert shown)

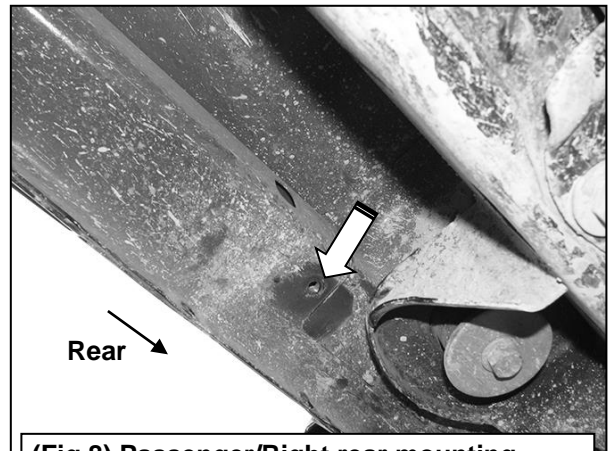

(Fig 8) Passenger/Right rear mounting location (Model with threaded inset shown)

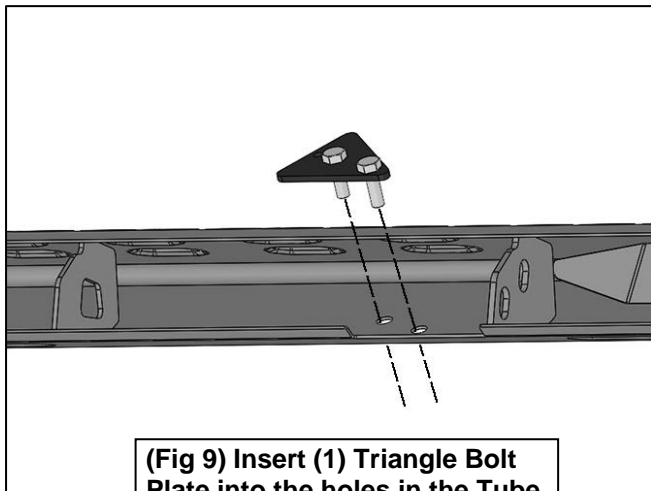

(Fig 9) Insert (1) Triangle Bolt Plate into the holes in the Tube

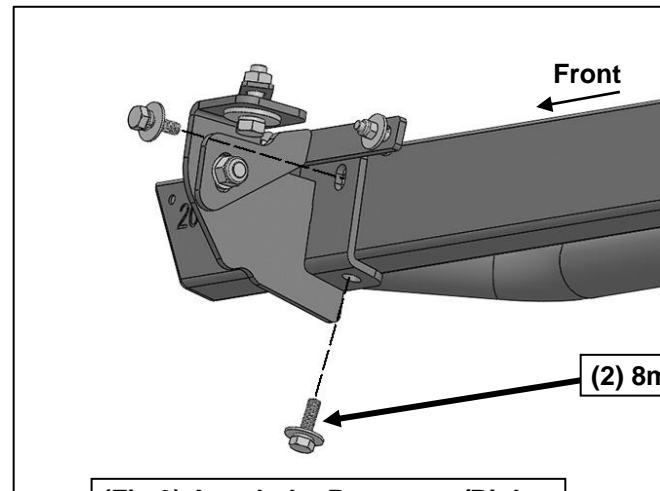

(Fig 9) Attach the Passenger/Right Side Step to the Mounting Brackets

- 8mm Bolt Plate
- (2) 8mm x 22mm Flat Washers
- (2) 8mm Nylon Lock Nuts

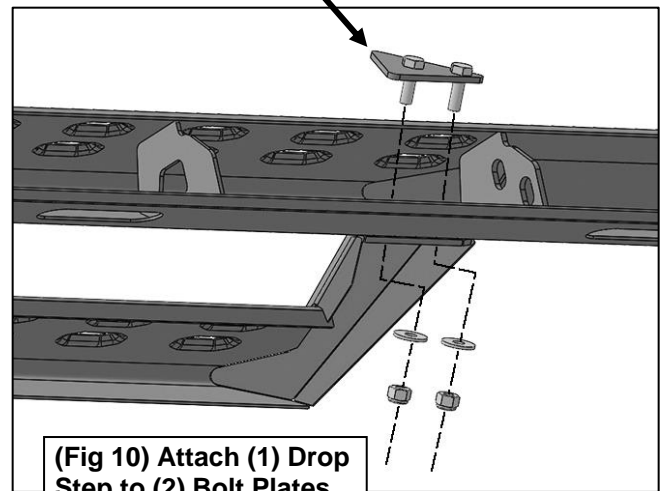

(Fig 10) Attach (1) Drop Step to (2) Bolt Plates