

Parts List:

1	Driver/Left Tube	24	10mm x 20mm OD x 2mm Flat Washers
1	Passenger/Right Tube	12	10mm Nylon Lock Nuts
2	Drop Steps	4	8mm x 25mm Triangle Double Bolt Plates
1	Driver/Left Front Mounting Bracket	4	8mm x 35mm Hex Bolts
1	Passenger/Right Front Mounting Bracket	4	8mm Lock Washers
1	Driver/Left Rear Mounting Bracket	4	8mm x 28mm OD x 3mm Flat Washers
1	Passenger/Right Rear Mounting Bracket	8	8mm x 22mm OD x 2mm Flat Washers
1	Driver/Left Front Support Bracket	8	8mm Nylon Lock Nuts
1	Passenger/Right Front Support Bracket	4	6mm Double Bolt Plates
1	Driver/Left Rear Support Bracket	8	6mm x 22mm OD x 2mm Flat Washers
1	Passenger/Right Rear Support Bracket	8	6mm Nylon Lock Nuts
12	10mm x 30mm Hex Bolts		

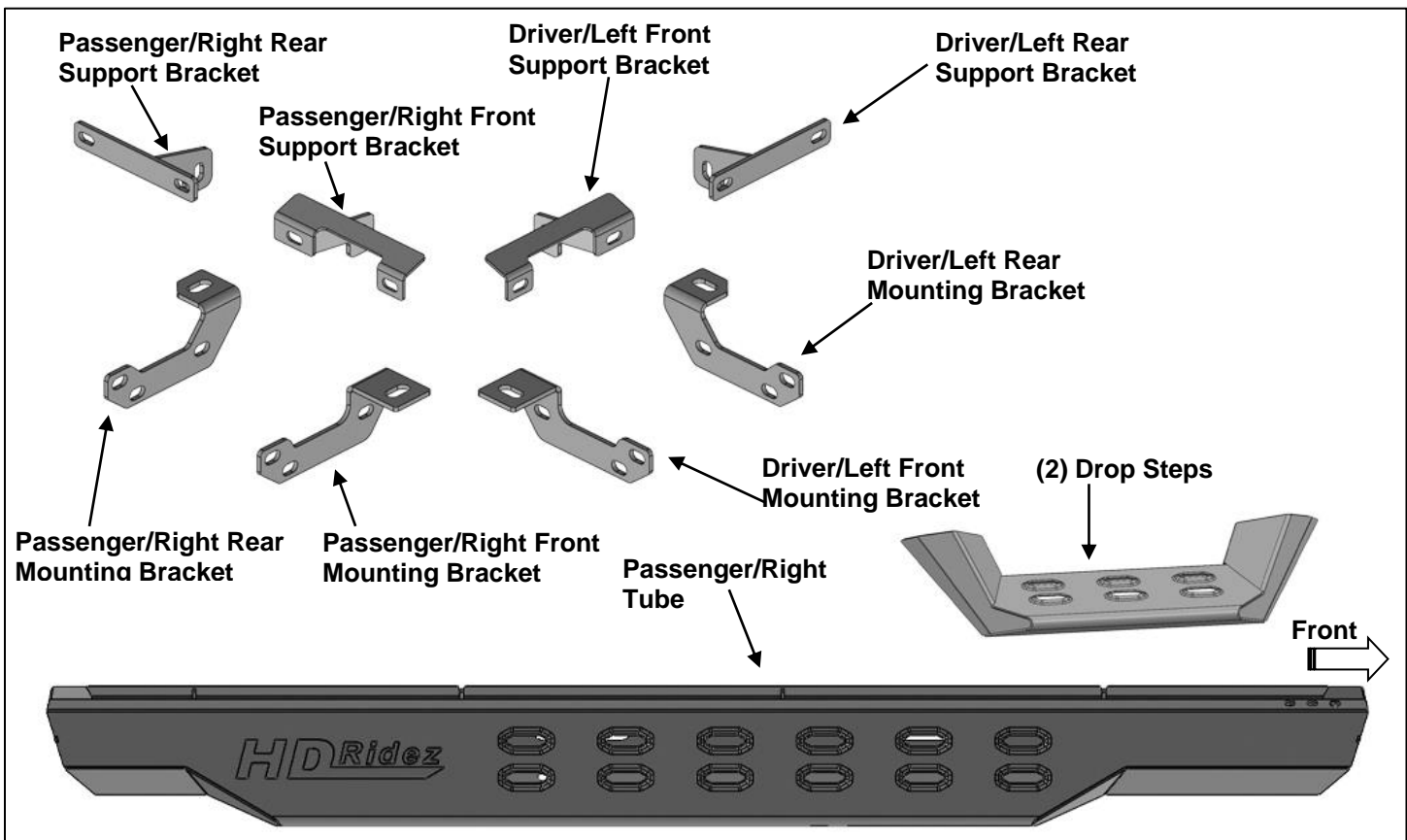

PROCEDURE:

- 1. REMOVE CONTENTS FROM BOX. VERIFY ALL PARTS ARE PRESENT. READ INSTRUCTIONS CAREFULLY BEFORE STARTING INSTALLATION. FACTORY INSTALLED OR AFTERMARKET SIDE PRODUCTS MUST BE REMOVED.**
2. Start installation toward the front of the Passenger/Right side of the vehicle and find the front threaded insert located in between the first pair of holes along the pinch weld, **(Figure 1)**.
3. Select the Passenger/Right Front Mounting Bracket, **(Figure 2)**. Attach the Bracket to the threaded insert using (1) 8mm Hex Bolt, (1) 8mm Lock Washer and (1) 8mm Flat Washer, **(Figure 2)**. Do not tighten hardware.
4. Next, select the Passenger/Right Front Support Bracket, **(Figure 3)**. Attach the Support Bracket to the pinch weld with (2) 6mm Double Bolt Plates, (4) 6mm Flat Washers and (2) 6mm Nylon Lock Nuts, **(Figure 3)**. Attach the Support Bracket to the Mounting Bracket with (1) 10mm Hex Bolt, (2) 10mm Flat Washers and (1) 10mm Nylon Lock Nut, **(Figure 4)**. **NOTE:**

Insert bolts from the outside of the pinch weld and through the Bracket. Do not tighten hardware.

5. Move to the rear mounting location and locate the threaded insert and pair of holes on the pinch weld, **(Figure 5)**. Repeat **Steps 3 & 4** to install the Rear Brackets.
6. Select the Passenger/Right Tube. Insert (2) 8mm Double Bolt Plates into the front (2) sets of (2) holes, **(Figure 6)**. Attach (1) Drop Step to the (2) Double Bolt Plates with (4) 8mm x 22mm Flat Washers and (4) 8mm Nylon Lock Nuts, **(Figure 7)**. Do not tighten hardware.
7. With assistance, line up the mounting tabs in the Passenger/Right Tube to the rear faces of the Mounting Brackets. Secure the Tube to the Mounting Brackets with (4) 10mm Hex Bolts, (8) 10mm x 20mm Flat Washers and (4) 10mm Nylon Lock Nuts, **(Figure 8)**. Do not tighten hardware.
8. Level and adjust the Overland Step, then tighten all hardware.
9. Repeat **Steps 1—8** to attach the Driver/Left Overland Step.
10. Do periodic inspections to the installation to make sure that all hardware is secure and tight.

To protect your investment, Do not use any type of polish or wax that may contain abrasives that could damage the finish. Mild soap may be used to clean Overland Sliders.

Passenger/Right Side Installation Pictured

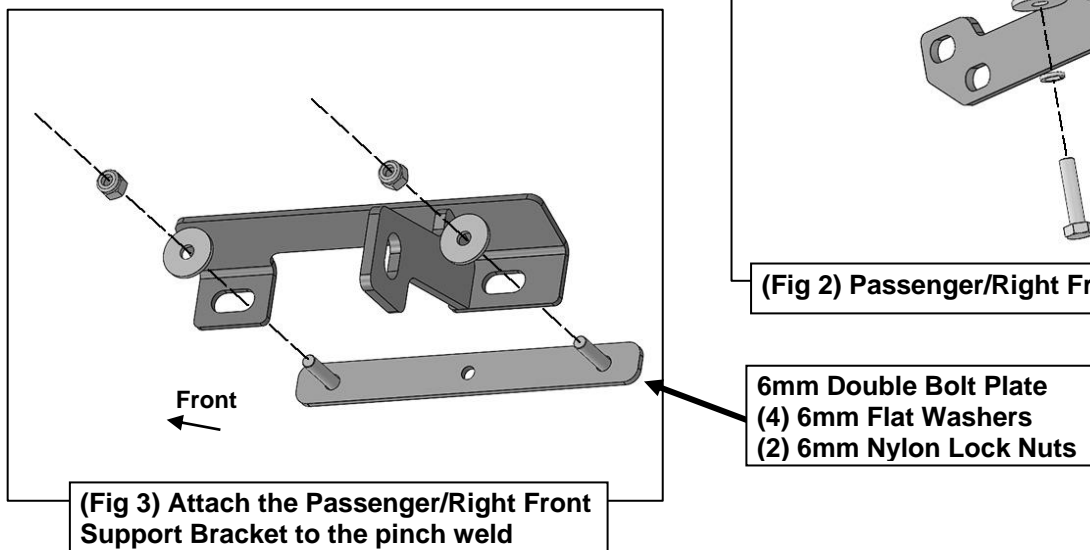
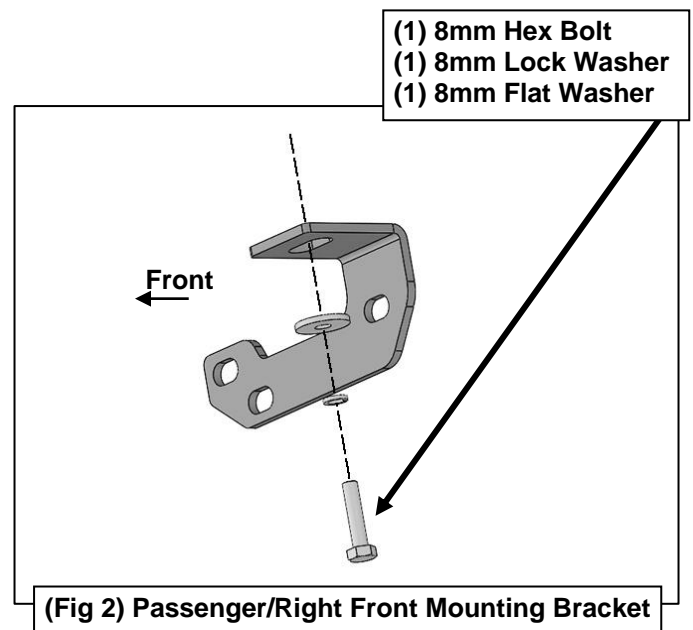
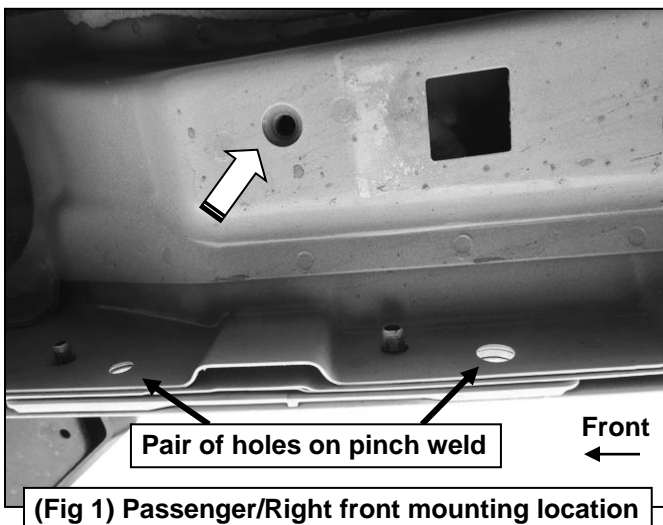

Passenger/Right Side Installation Pictured

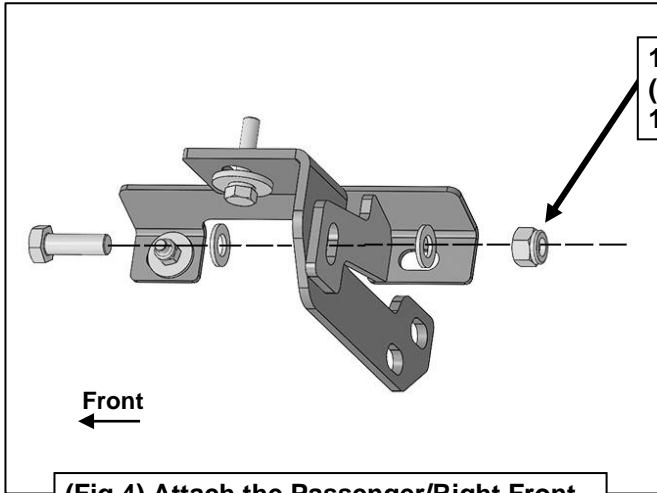

10mm Hex Bolt
(2) 10mm Flat Washers
10mm Nylon Lock Nut

(Fig 4) Attach the Passenger/Right Front Support Bracket to the Mounting Bracket

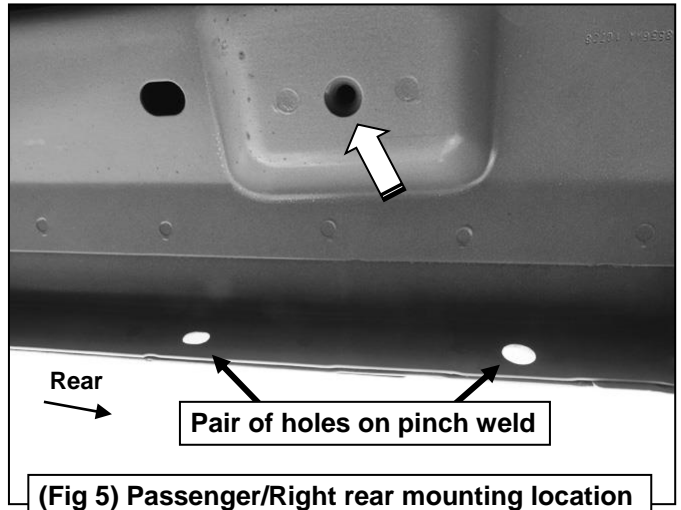

(Fig 5) Passenger/Right rear mounting location

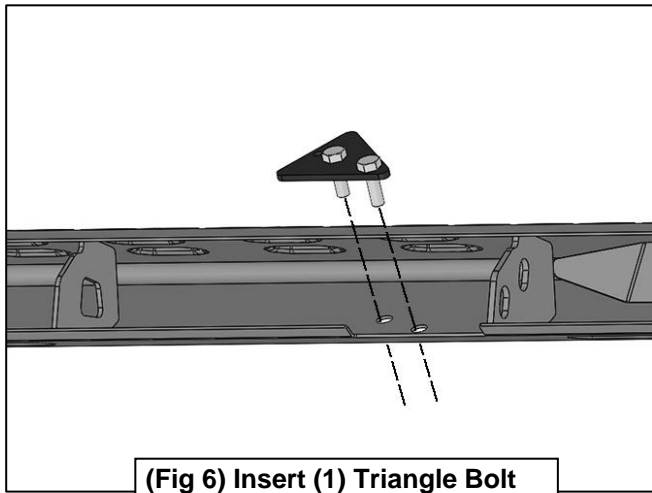

(Fig 6) Insert (1) Triangle Bolt Plate into the holes in the Tube

8mm Triangle Bolt Plate
(2) 8mm Flat Washers
(2) 8mm Nylon Lock Nuts

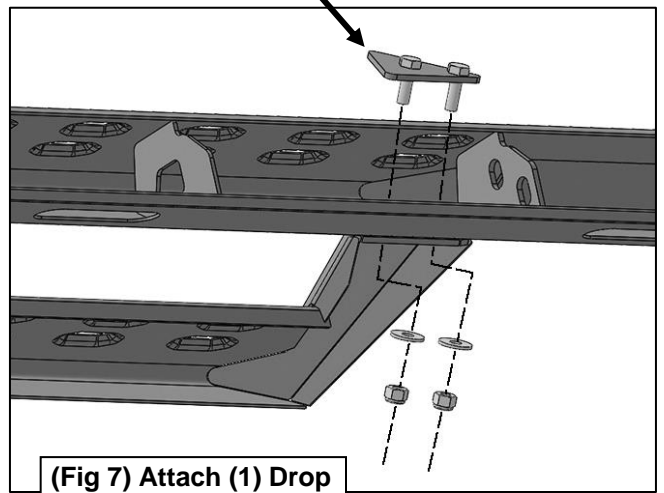

(Fig 7) Attach (1) Drop Step to (2) Bolt Plates

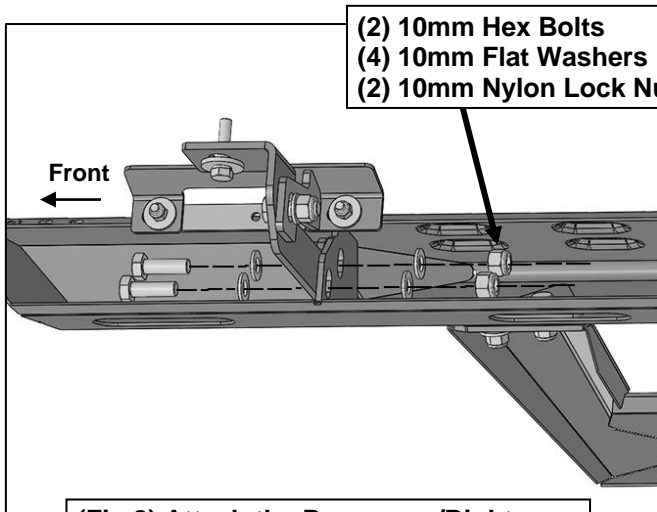

(Fig 8) Attach the Passenger/Right Overland Slider the Mounting Brackets