

**Parts List:**

1	Driver/Left Main Tube	8	8mm x 25mm Double Bolt Plates
1	Passenger/Right Main Tube	6	6mm Double Bolt Plate
4	Drop Steps	18	10mm x 30mm Hex Bolts
1	Driver/Left Front Mounting Bracket	18	10mm Nylon Lock Nuts
1	Passenger/Right Front Mounting Bracket	36	10mm x 20mm OD x 2mm Flat Washers
1	Driver/Left Center Mounting Bracket	6	8mm x 35mm Hex Bolts
1	Passenger/Right Center Mounting Bracket	6	8mm Lock Washers
1	Driver/Left Rear Mounting Bracket	6	8mm x 28mm OD x 3mm Flat Washers
1	Passenger/Right Rear Mounting Bracket	16	8mm Nylon Lock Nuts (Drop Step Assembly)
1	Driver/Left Front Support Bracket	16	8mm x 22mm OD x 2mm Flat Washers (Drop Step Assembly)
1	Passenger/Right Front Support Bracket	12	6mm Nylon Lock Nuts
2	Driver/Left Center/Rear Support Brackets	12	6mm x 22mm OD x 2mm Flat Washers
2	Passenger/Right Center/Rear Support Brackets		

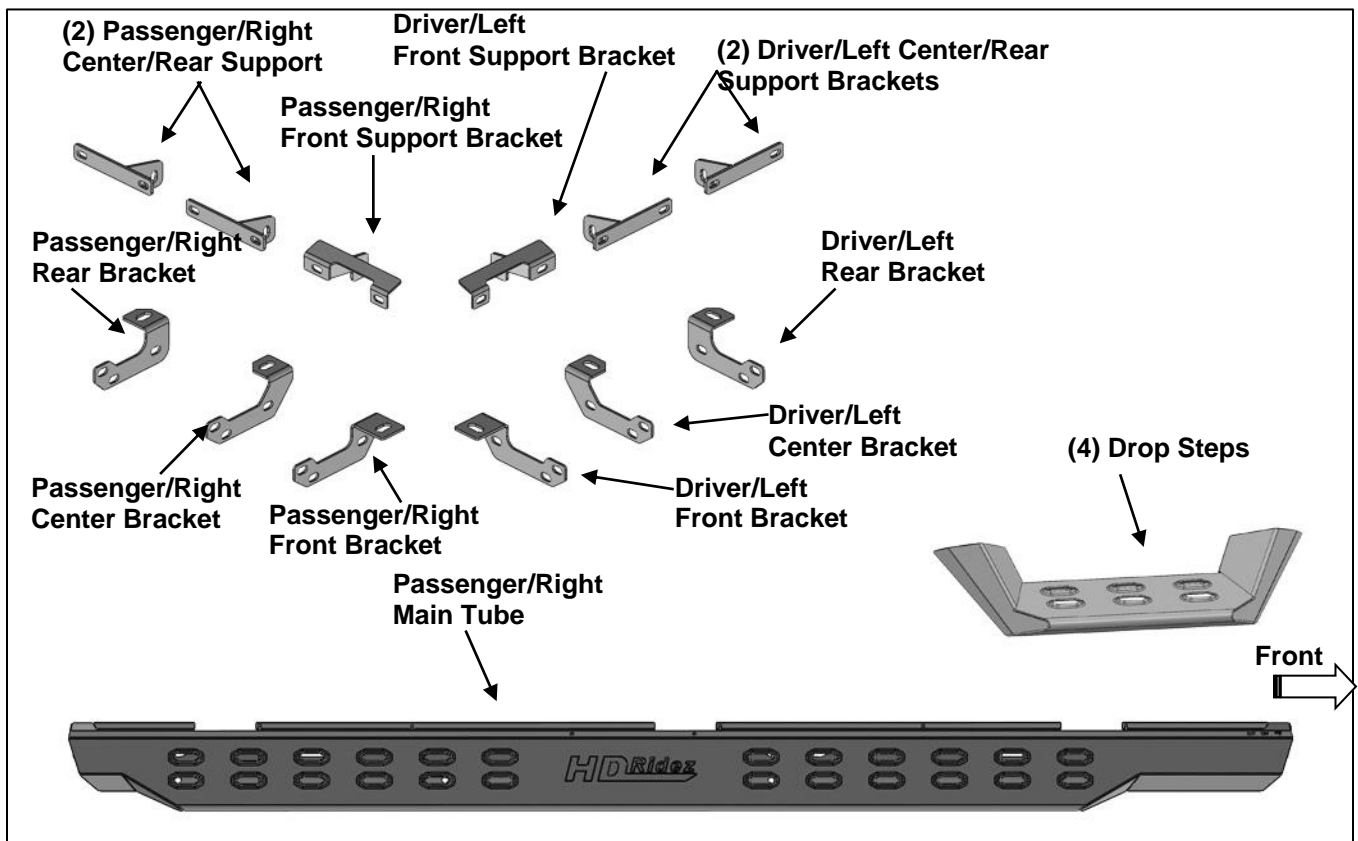

**PROCEDURE:**

1. REMOVE CONTENTS FROM BOX. VERIFY ALL PARTS ARE PRESENT. READ INSTRUCTIONS CAREFULLY BEFORE STARTING INSTALLATION. SIDE STEPS OR RUNNING BOARDS MUST BE REMOVED BEFORE INSTALLATION.
2. Start installation on the Passenger/Right front of the vehicle. Find the front threaded insert located in between the first pair of holes along the pinch weld, **(Figure 1)**.
3. Select the Passenger/Right Front Mounting Bracket. **IMPORTANT:** Use the illustration above to properly identify the Mounting Bracket. Attach the Mounting Bracket to the threaded insert using (1) 8mm Hex Bolt, (1) 8mm Lock Washer and (1) 8mm x 28mm Flat Washer, **(Figure 2)**. Do not tighten hardware.
4. Select the Passenger/Right Front Support Bracket. **IMPORTANT:** Use the illustration above to help identify the correct Support Bracket. Attach the Support Bracket to the pinch weld using (1) 6mm

Double Bolt Plate, (2) 6mm Flat Washers and (2) 6mm Nylon Lock Nuts, **(Figure 3)**. **NOTE: Insert Bolt Plate from the outside of the pinch weld.** Attach the Support Bracket to the Mounting Bracket with (1) 10mm Hex Bolt, (2) 10mm Flat Washers and (1) 10mm Nylon Lock Nut, **(Figure 4)**. Do not tighten hardware.

5. Move to the center mounting location and locate the threaded insert and pair of holes in the pinch weld, **(Figure 5)**. Repeat **Steps 3 & 4** to attach the Passenger/Right Center Mounting Bracket and (1) Passenger/Right Center/Rear Support Bracket, **(Figures 5 - 8)**. Do not tighten hardware.
6. Move to the rear mounting location on the rocker panel and locate the threaded insert and pair of holes in the pinch weld, **(Figure 9)**. Repeat **Steps 3 & 4** to attach the Passenger/Right Rear Mounting Bracket and (1) Passenger/Right Center/Rear Support Bracket, **(Figures 9 - 12)**. Do not tighten hardware.
7. Select the Passenger/Right Main Tube. **IMPORTANT:** Use the illustration above to help identify the correct Main Tube. Insert (2) 8mm Bolt Plates into the front (2) sets of (2) holes, **(Figure 13)**. Attach (1) Drop Step to the (2) Bolt Plates with (4) 8mm x 22mm Flat Washers and (4) 8mm Nylon Lock Nuts, **(Figure 14)**. Do not tighten hardware.
8. With assistance, line up the holes in the mounting tabs on the Running Board to the rear facing slots in the Mounting Brackets. Attach the Passenger/Right Main Tube to the Mounting Brackets with (6) 10mm Hex Bolts, (12) 10mm Flat Washers and (6) 10mm Nylon Lock Nuts, **(Figure 15)**. Do not tighten hardware.
9. Level and adjust the Passenger/Right Main Tube and tighten all hardware.
10. Repeat **Steps 1—9** for the Driver/Left Main Tube installation.
11. Do periodic inspections to the installation to make sure that all hardware is secure and tight.

**To protect your investment,** Do not use any type of polish or wax that may contain abrasives that could damage the finish. Mild soap may be used to clean Slider Drop Step.

### Passenger/Right Side Installation Pictured

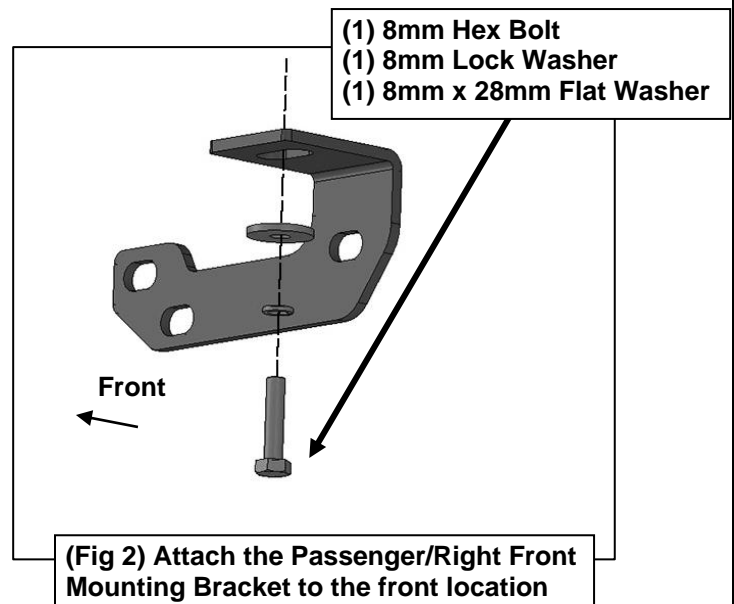
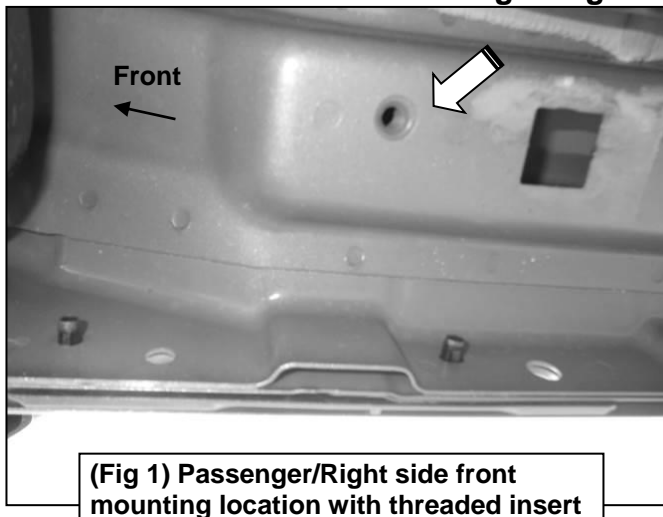

### Passenger/Right Side Installation Pictured

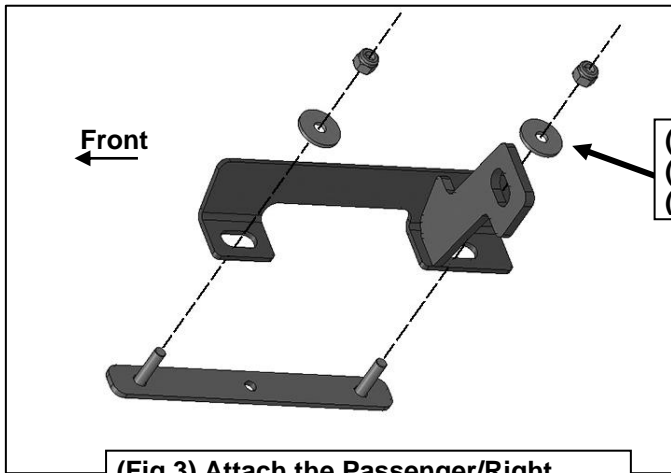

(Fig 3) Attach the Passenger/Right Front Support Bracket to the pinch trim

- (1) 6mm Double Bolt Plate
- (2) 6mm Flat Washers
- (2) 6mm Nylon Lock Nuts

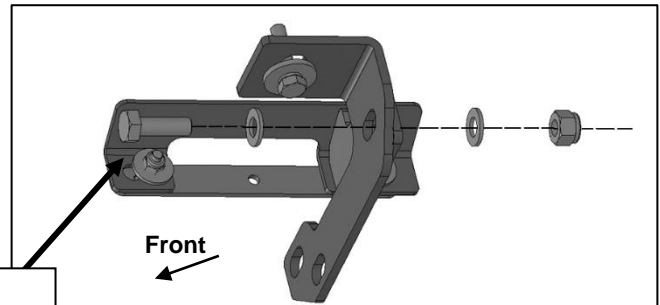

(Fig 4) Attach the Passenger/Right Front Support Bracket to the pinch weld

- (1) 10mm Hex Bolt
- (2) 10mm Flat Washers
- (1) 10mm Nylon Lock Nut

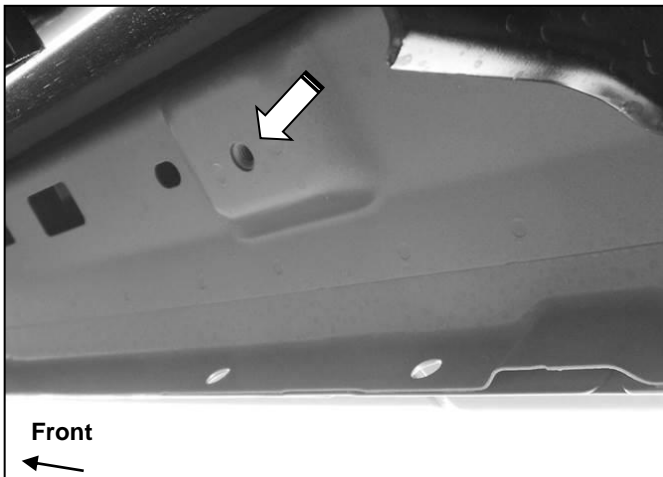

(Fig 5) Passenger/Right center mounting location

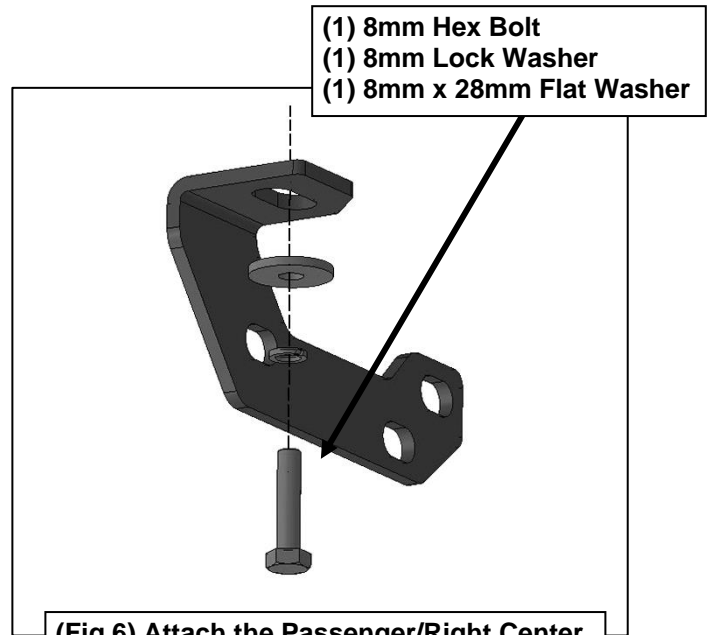

(Fig 6) Attach the Passenger/Right Center Mounting Bracket to the center location

- (1) 8mm Hex Bolt
- (1) 8mm Lock Washer
- (1) 8mm x 28mm Flat Washer

### Passenger/Right Side Installation Pictured

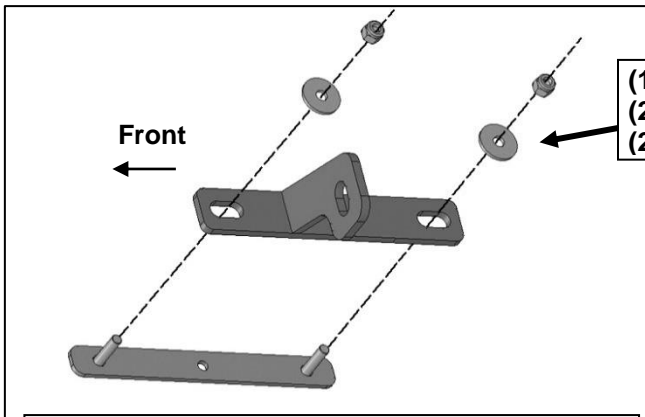

- (1) 6mm Double Bolt Plate
- (2) 6mm Flat Washers
- (2) 6mm Nylon Lock Nuts

(Fig 7) Attach the Passenger/Right Center/Rear Support Bracket to the pinch trim

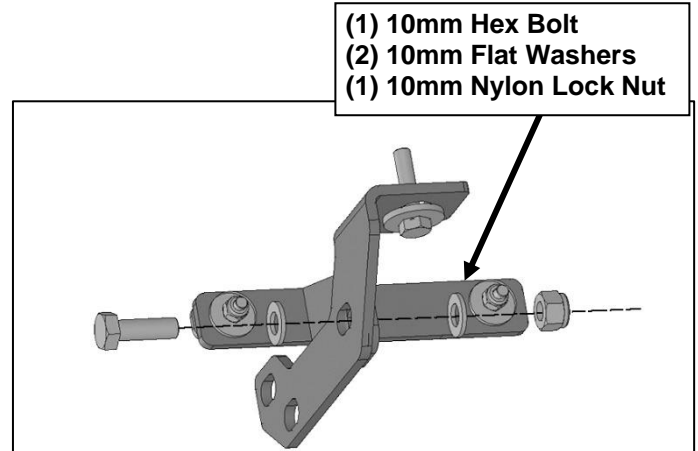

- (1) 10mm Hex Bolt
- (2) 10mm Flat Washers
- (1) 10mm Nylon Lock Nut

(Fig 8) Attach the Passenger/Right Center/Rear Support Bracket to the pinch weld

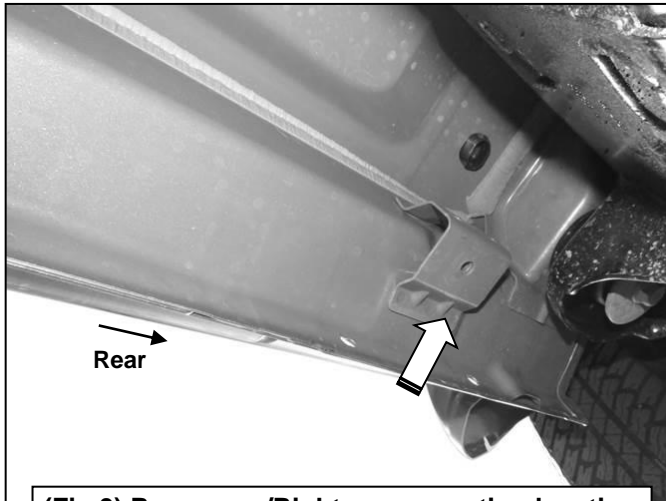

(Fig 9) Passenger/Right rear mounting location

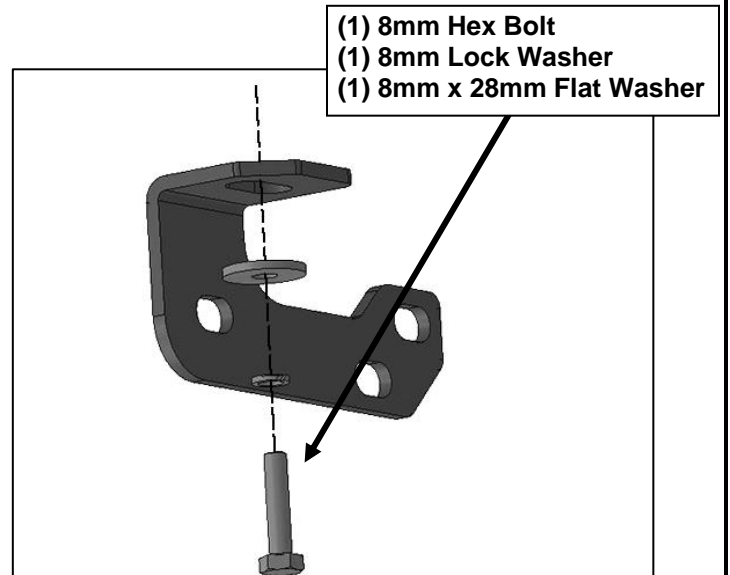

- (1) 8mm Hex Bolt
- (1) 8mm Lock Washer
- (1) 8mm x 28mm Flat Washer

(Fig 10) Attach the Passenger/Right Rear Mounting Bracket to the rear location

### Passenger/Right Side Installation Pictured

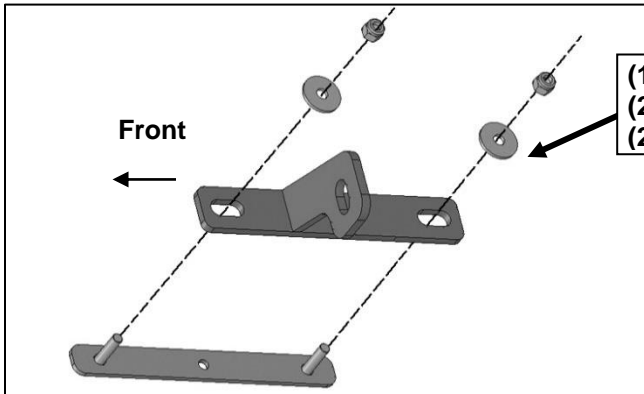

- (1) 6mm Double Bolt Plate
- (2) 6mm Flat Washers
- (2) 6mm Nylon Lock Nuts

(Fig 11) Attach the Passenger/Right Center/Rear Support Bracket to the pinch trim

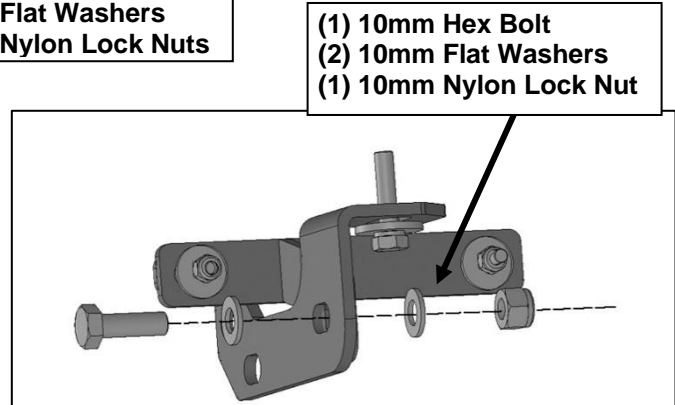

- (1) 10mm Hex Bolt
- (2) 10mm Flat Washers
- (1) 10mm Nylon Lock Nut

(Fig 12) Attach the Passenger/Right Center/Rear Support Bracket to the pinch weld

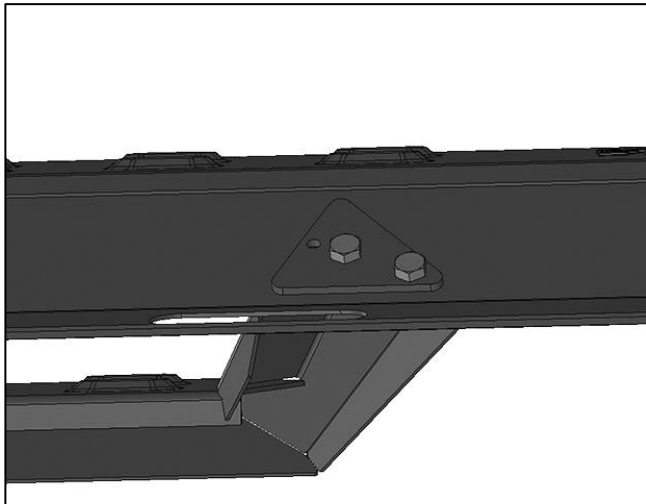

(Fig 13) Insert (1) Bolt Plate into the holes in the Tube

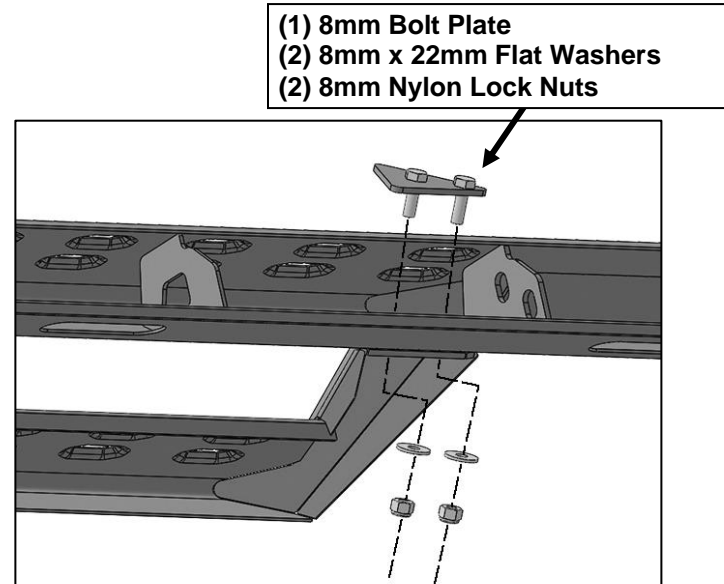

- (1) 8mm Bolt Plate
- (2) 8mm x 22mm Flat Washers
- (2) 8mm Nylon Lock Nuts

(Fig 14) Attach (1) Drop Step to (2) Bolt Plates

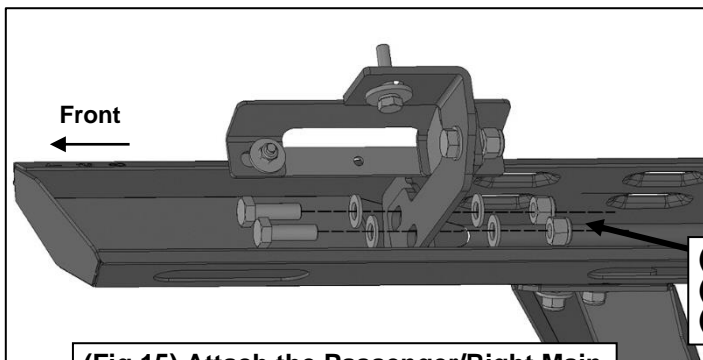

- (2) 10mm Hex Bolts
- (4) 10mm Flat Washers
- (2) 10mm Nylon Lock Nuts

(Fig 15) Attach the Passenger/Right Main Tube to the Mounting Brackets