

**PARTS LIST:**

1	Driver/Left DS4 Running Board	12	10mm x 30mm Hex Bolts
1	Passenger/Right DS4 Running Board	24	10mm x 20mm OD x 2mm Flat Washers
1	Driver/Left Front Mounting Bracket	12	10mm Nylon Lock Nuts
1	Passenger/Right Front Mounting Bracket	4	8mm x 35mm Hex Bolts
1	Driver/Left Rear Mounting Bracket	4	8mm Lock Washers
1	Passenger/Right Rear Mounting Bracket	4	8mm x 28mm OD x 3mm Flat Washers
1	Driver/Left Front Support Bracket	4	6mm Double Bolt Plates
1	Passenger/Right Front Support Bracket	8	6mm x 22mm OD x 2mm Flat Washers
1	Driver/Left Rear Support Bracket	8	6mm Nylon Lock Nuts
1	Passenger/Right Rear Support Bracket		

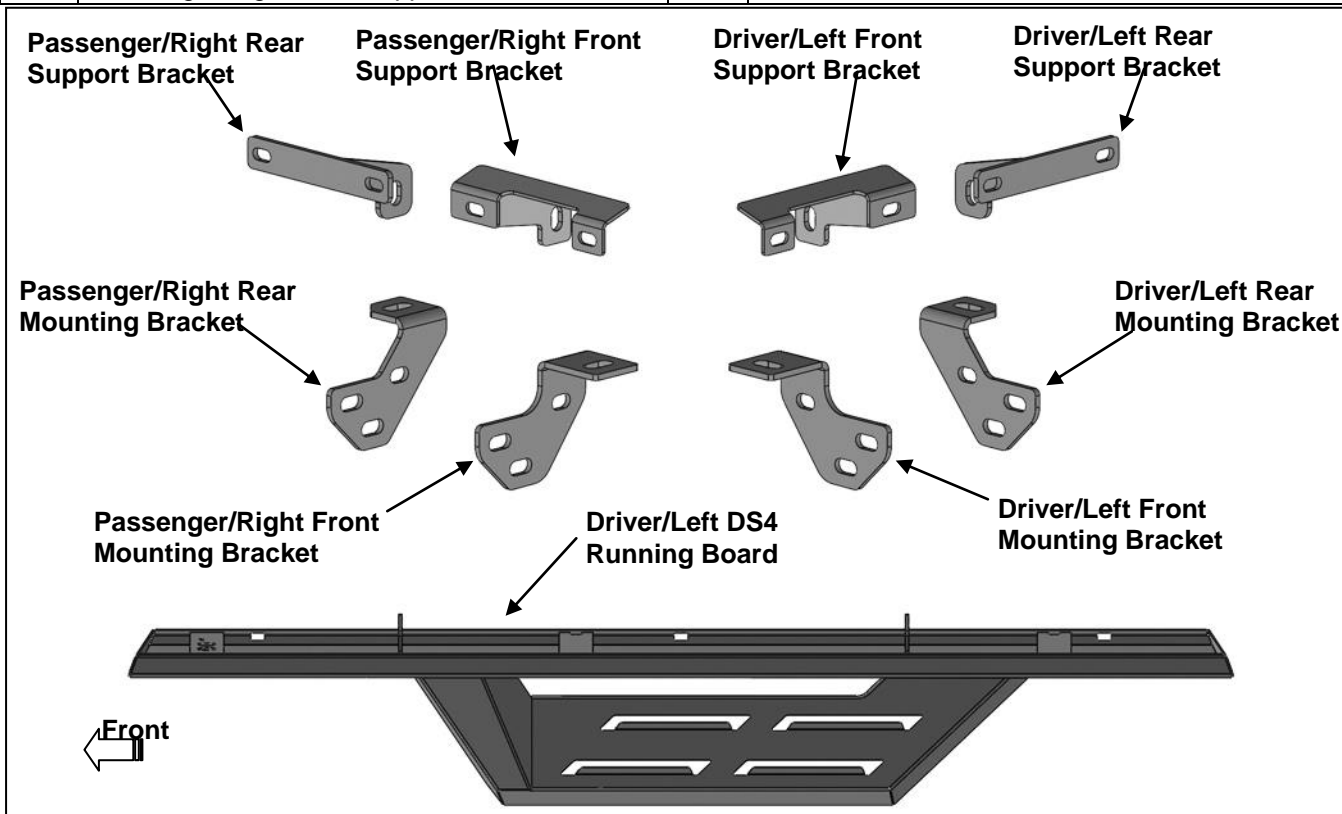

**PROCEDURE:**

**REMOVE CONTENTS FROM BOX. VERIFY ALL PARTS ARE PRESENT. READ INSTRUCTIONS CAREFULLY. FACTORY INSTALLED OR AFTERMARKET "ROCK RAILS," SIDE STEPS OR RUNNING BOARDS MUST BE REMOVED. ASSISTANCE IS HIGHLY RECOMMENDED.**

1. Start installation on the Driver/Left side of the vehicle. Locate the (3) pairs of factory mounting holes along the pinch weld, **(Figures 1 & 5)**.
2. Select the Driver/Left Front Mounting Bracket. Attach the Mounting Bracket to the front location with (1) 8mm Hex Bolt, (1) 8mm Lock Washer and (1) 8mm Flat Washer, **(Figures 1 & 2)**. Do not tighten hardware.
3. Select the Driver/Left Front Support Bracket. Attach the Support Bracket to the pinch trim with (1) 6mm Double Bolt Plate, (2) 6mm Flat Washers and (2) 6mm Nylon Lock Nuts, **(Figure 3)**. Attach the Support Bracket to the Mounting Bracket with (1) 10mm Hex Bolt, (2) 10mm Flat Washers and (1) 10mm Nylon Lock Nut, **(Figure 4)**. Do not tighten hardware.
4. Repeat **Steps 1—3** to attach the Driver/Left Rear Mounting Bracket and Support Bracket.

5. Select the Driver/Left DS4 Running Board. With assistance, attach the Running Board to the rear faces of the Mounting Brackets with (4) 10mm Hex Bolts, (8) 10mm Flat Washers and (4) 10mm Nylon Lock Nuts, **(Figure 6)**. Do not tighten hardware.
6. Level and adjust the Running Board and tighten all hardware.
7. Repeat **Steps 1—6** to attach the Passenger/Right DS4 Running Board.
8. Do periodic inspections to the installation to make sure that all hardware is secure and tight.

**To protect your investment,** Do not use any type of polish or wax that may contain abrasives that could damage the finish. Mild soap may be used to clean the Running Boards.

### Driver/Left side Installation Pictured

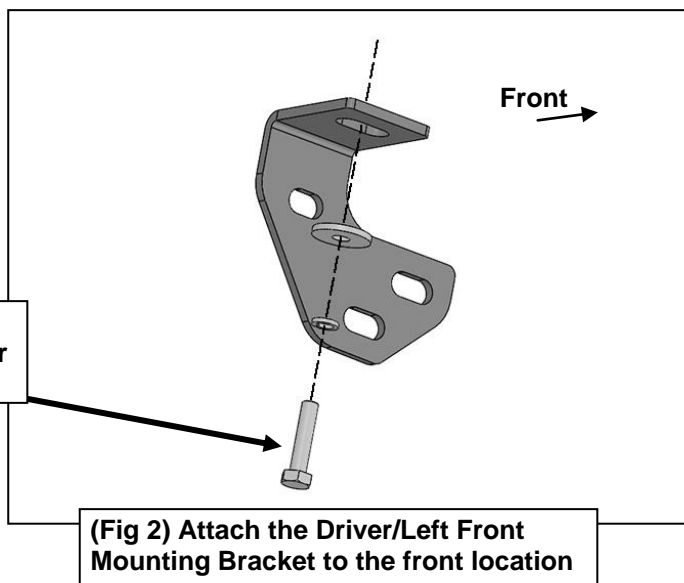
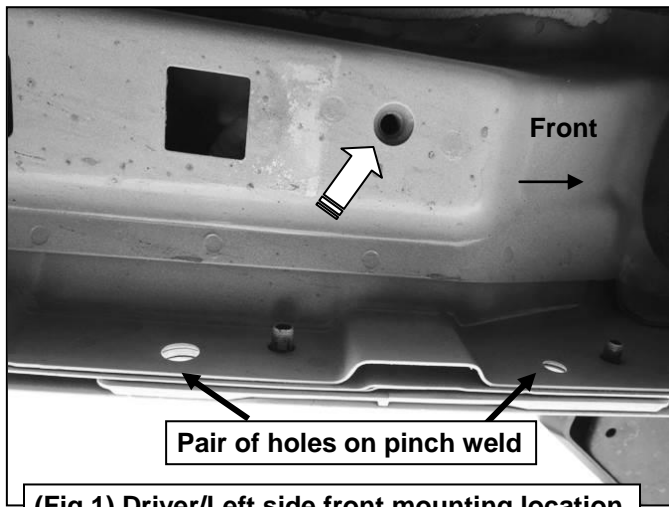

8mm Hex Bolt  
8mm Lock Washer  
8mm Flat Washer

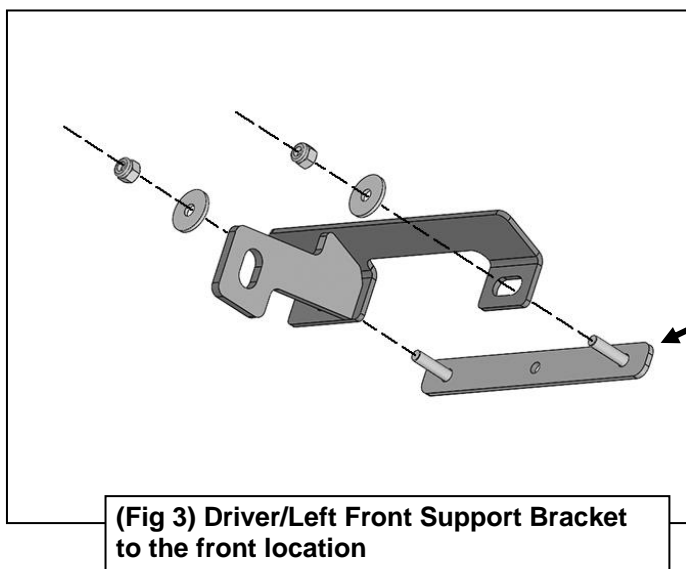

(1) 6mm Double Bolt Plate  
(4) 6mm Flat Washers  
(2) 6mm Nylon Lock Nuts

### Driver/Left side Installation Pictured

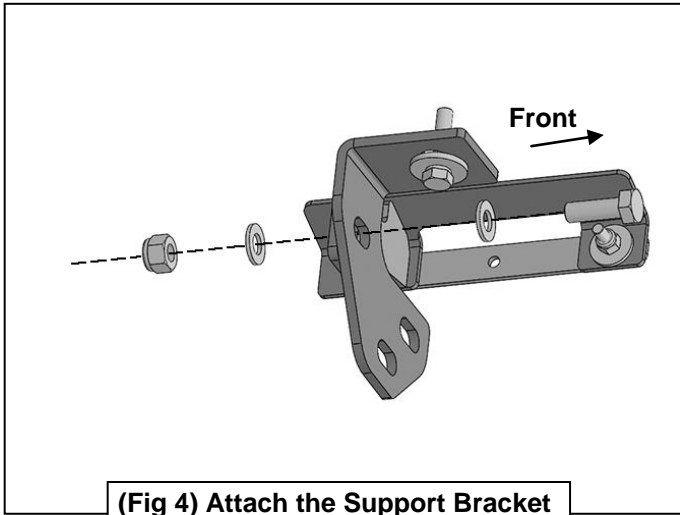

**(Fig 4) Attach the Support Bracket to the Mounting Bracket**

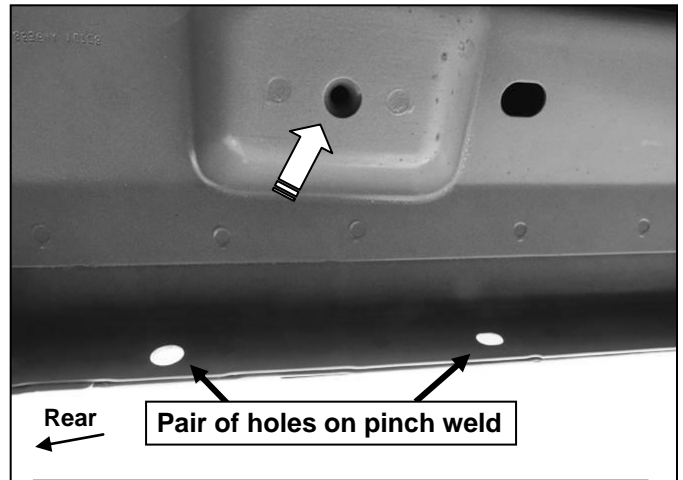

**(Fig 5) Driver/Left side rear mounting location**

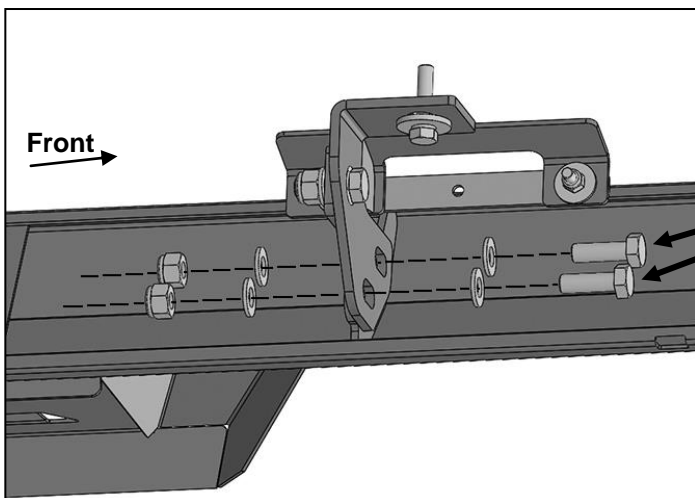

- (2) 10mm Hex Bolts
- (4) 10mm Flat Washers
- (2) 10mm Nylon Lock Nuts

**(Fig 6) Attach the Driver/Left DS4 Running Board to the rear faces of the Mounting Brackets**