

Parts List:

1	Driver/Left DS4 Running Board	2	Passenger/Right Center Support Brackets
1	Passenger/Right DS4 Running Board	1	Driver/Left Rear Support Bracket
1	Driver/Left Front Mounting Bracket	1	Passenger/Right Rear Support Bracket
1	Passenger/Right Front mounting Bracket	24	10mm x 30mm Hex Bolts
1	Driver/Left 2nd Mounting Bracket	48	10mm x 20mm OD x 2mm Flat Washers
1	Passenger/Right 2nd Mounting Bracket	24	10mm Nylon Lock Nuts
1	Driver/Left 3rd Mounting Bracket	8	8mm x 35mm Hex Bolts
1	Passenger/Right 3rd Mounting Bracket	8	8mm Lock Washers
1	Driver/Left Rear Mounting Bracket	8	8mm x 28mm OD x 3mm Flat Washers
1	Passenger/Right Rear Mounting Bracket	8	6mm Double Bolt Plates
1	Driver/Left Front Support Bracket	16	6mm x 22mm OD x 2mm Flat Washers
1	Passenger/Right Front Support Bracket	16	6mm Nylon Lock Nuts
2	Driver/Left Center Support Brackets		

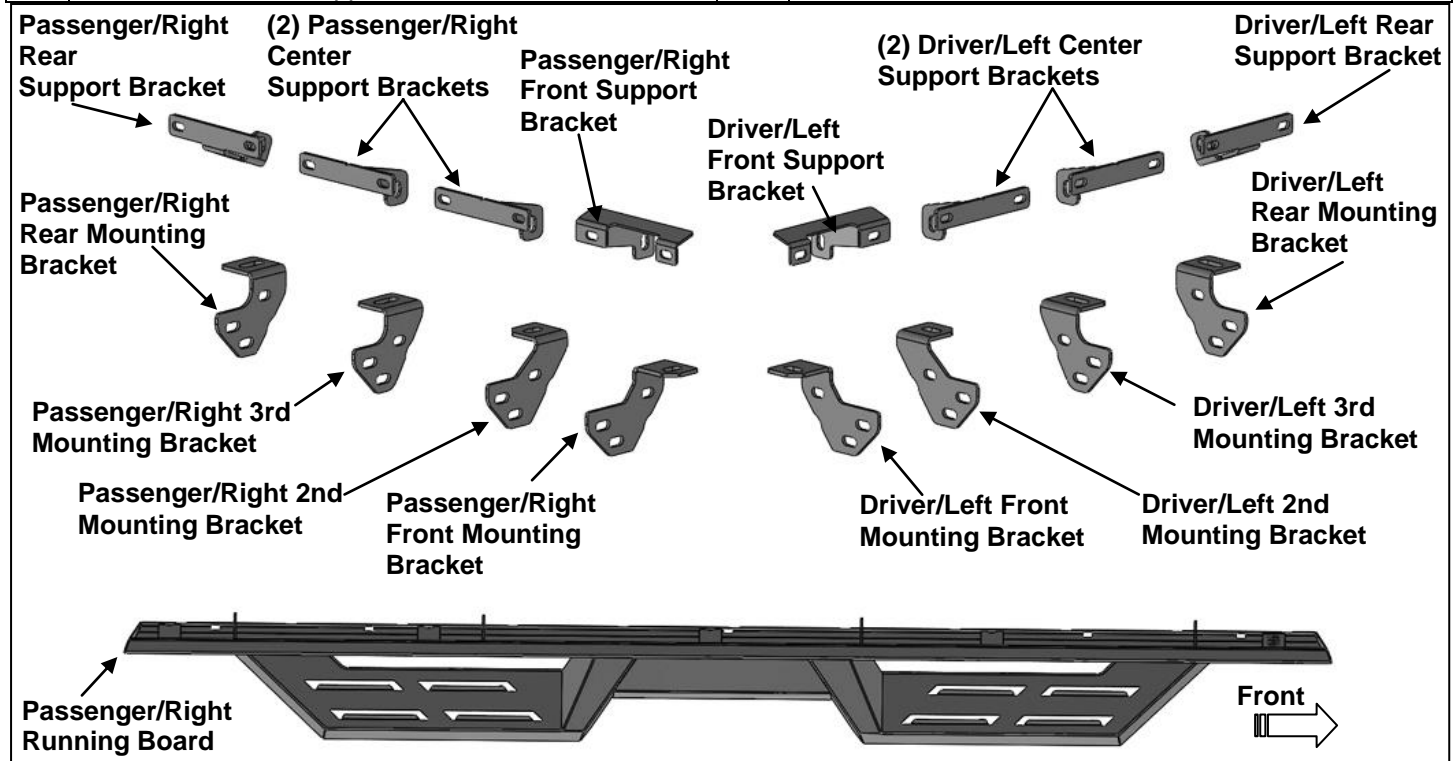

PROCEDURE:

1. REMOVE CONTENTS FROM BOX. VERIFY ALL PARTS ARE PRESENT. READ INSTRUCTIONS CAREFULLY BEFORE STARTING INSTALLATION. SIDE STEPS OR RUNNING BOARDS MUST BE REMOVED BEFORE INSTALLATION.
2. Start installation on the Passenger/Right front of the vehicle. Find the front threaded insert located in between the first pair of holes along the pinch weld, **(Figure 1)**.
3. Select the Passenger/Right Front Mounting Bracket, **(Figure 2)**. Attach the Mounting Bracket to the threaded insert using (1) 8mm Hex Bolt, (1) 8mm Lock Washer and (1) 8mm Flat Washer, **(Figure 2)**. Do not tighten hardware.
4. Select the Passenger/Right Front Support Bracket. Attach the Support Bracket to the pinch weld using (1) 6mm Double Bolt Plates, (2) 6mm Flat Washers and (2) 6mm Nylon Lock Nuts, **(Figure 3)**. **NOTE: Insert bolt plate from the outside of the pinch weld and through the Bracket.** Attach the Support Bracket to the Mounting Bracket with (1) 10mm Hex Bolt, (2) 10mm Flat Washers and (1) 10mm Nylon Lock Nut, **(Figures 4 & 5)**. Do not tighten hardware.
5. Move to the 2nd mounting location and locate the threaded insert and pair of holes in the pinch weld, **(Figure 6)**. Repeat **Steps 3 & 4** to attach the Passenger/Right 2nd Mounting Bracket and (1) Passenger/Right Center Support Bracket, **(Figures 6 & 7)**. Do not tighten hardware.

6. Move to the 3rd mounting location on the rocker panel and locate the threaded insert and pair of holes in the pinch weld. Repeat **Steps 3 & 4** to attach the Passenger/Right 3rd Mounting Bracket and (1) Passenger/Right Center Support Bracket, **(Figure 8)**. Do not tighten hardware.
7. Move to the rear mounting location on the rocker panel and locate the threaded insert and pair of holes in the pinch weld. Repeat **Steps 3 & 4** to attach the Passenger/Right Rear Mounting Bracket and the Passenger/Right Rear Support Bracket, **(Figure 9)**. Do not tighten hardware.
8. Select the Passenger/Right DS4 Running Board. With assistance, attach the Running Board to the rear faces of the (4) Mounting Brackets with (8) 10mm Hex Bolts, (16) 10mm Flat Washers and (8) 10mm Nylon Lock Nuts, **(Figure 10)**. Do not tighten hardware.
9. Level and adjust the Running Board and tighten all hardware.
10. Repeat **Steps 1—9** to attach the Driver/Left DS4 Running Board.
11. Do periodic inspections to the installation to make sure that all hardware is secure and tight.

To protect your investment, Do not use any type of polish or wax that may contain abrasives that could damage the finish. Mild soap may be used to clean Running Board.

Passenger/Right Side Installation Pictured

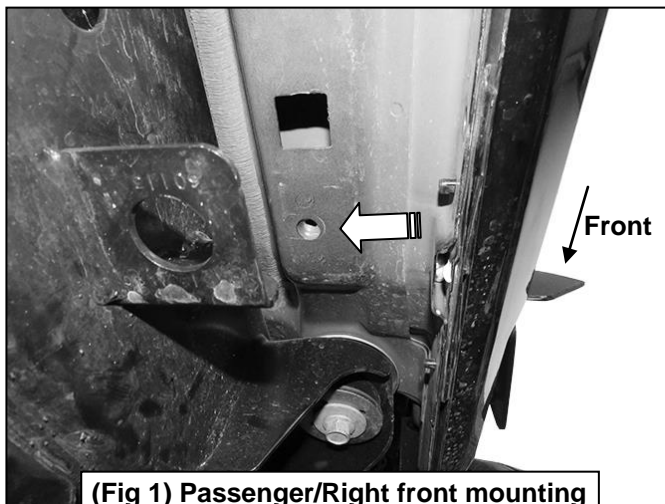

(Fig 1) Passenger/Right front mounting location with threaded insert

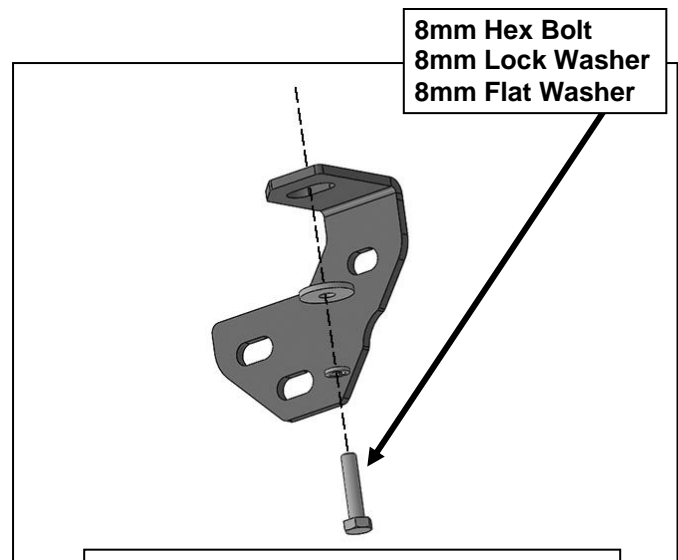

(Fig 2) Attach the Passenger/Right Front Mounting Bracket to the front location

Passenger/Right Side Installation Pictured

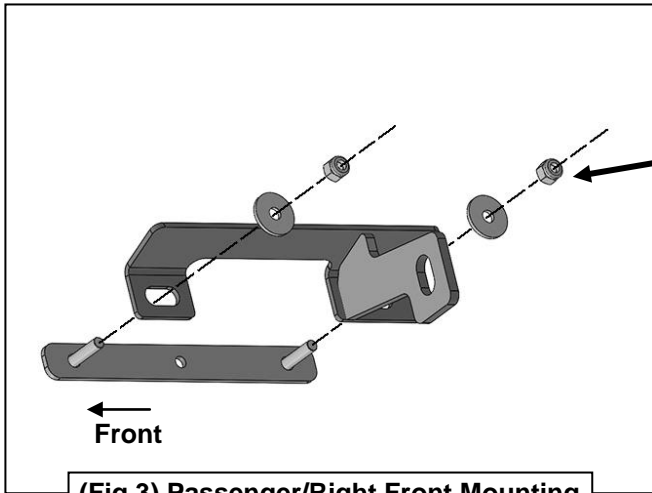

(Fig 3) Passenger/Right Front Mounting Bracket attached to the front location

6mm Double Bolt Plate
(4) 6mm Flat Washers
(2) 6mm Nylon Lock Nuts

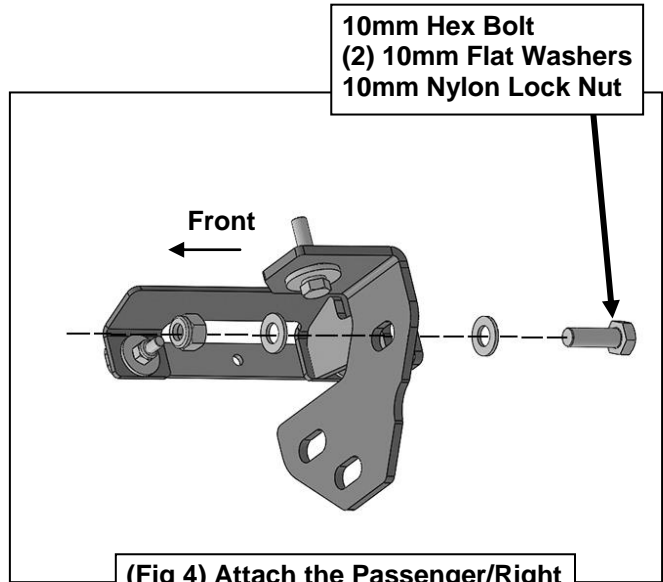

(Fig 4) Attach the Passenger/Right Support Bracket to the pinch weld and the Mounting Bracket

10mm Hex Bolt
(2) 10mm Flat Washers
10mm Nylon Lock Nut

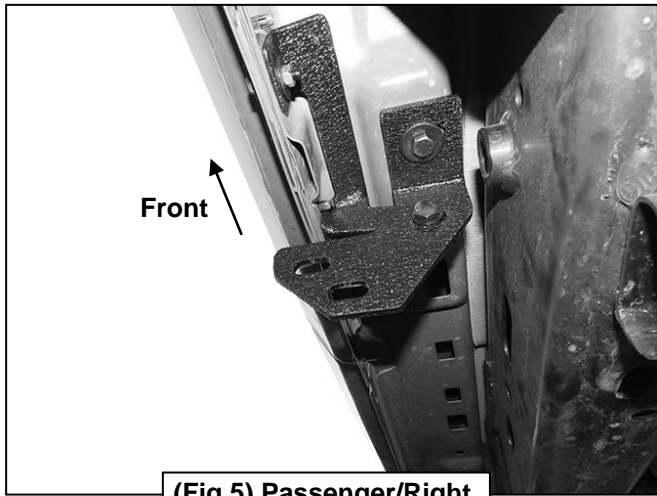

(Fig 5) Passenger/Right Front Brackets attached

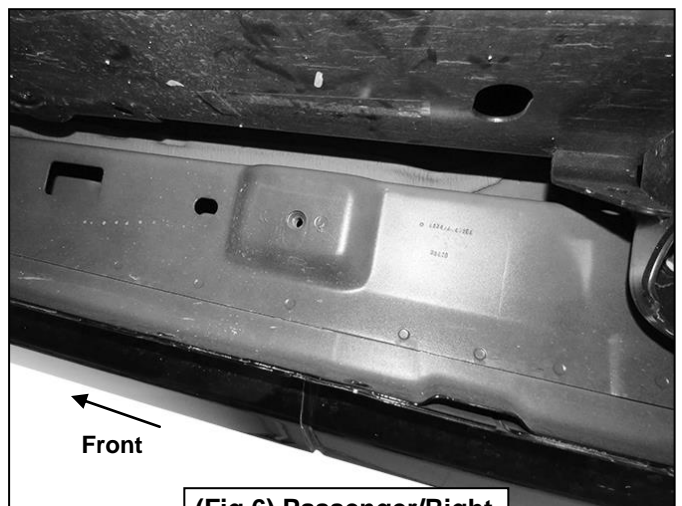

(Fig 6) Passenger/Right 2nd mounting location

Passenger/Right Side Installation Pictured



(Fig 7) Passenger/Right 2nd Mounting Bracket and (1) Center Support Bracket attached to the 2nd location



(Fig 8) Passenger/Right 3rd Mounting Bracket and (1) Center Support Bracket attached to the 3rd location



(Fig 9) Passenger/Right Rear Mounting Bracket and Rear Support Bracket attached to the rear location

- (2) 10mm Hex Bolts
- (4) 10mm Flat Washers
- (2) 10mm Nylon Lock Nuts

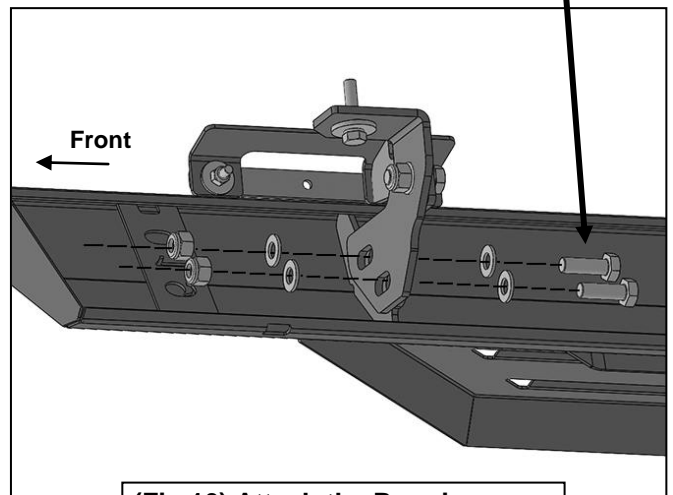

(Fig 10) Attach the Running Board to the Mounting Brackets