

**Parts List:**

1	Driver/Left DS4 Running Board	2	Passenger/Right Center/Right Support Brackets
1	Passenger/Right DS4 Running Board	18	10mm x 30mm Hex Bolts
1	Driver/Left Front Mounting bracket	36	10mm x 20mm OD x 2mm Flat Washers
1	Passenger/Right Front Mounting Bracket	18	10mm Nylon Lock Nuts
1	Driver/Left Center Mounting Bracket	6	8mm x 35mm Hex Bolts
1	Passenger/Right Center Mounting Bracket	6	8mm Lock Washers
1	Driver/Left Rear Mounting Bracket	6	8mm x 28mm OD x 3mm Flat Washers
1	Passenger/Right Rear Mounting Bracket	6	6mm Double Bolt Plates
1	Driver/Left Front Support Bracket	12	6mm x 22mm OD x2mm Flat Washers
1	Passenger/Right Front Support Bracket	12	6mm Nylon Lock Nuts
2	Driver/Left Center/Rear Support Brackets		

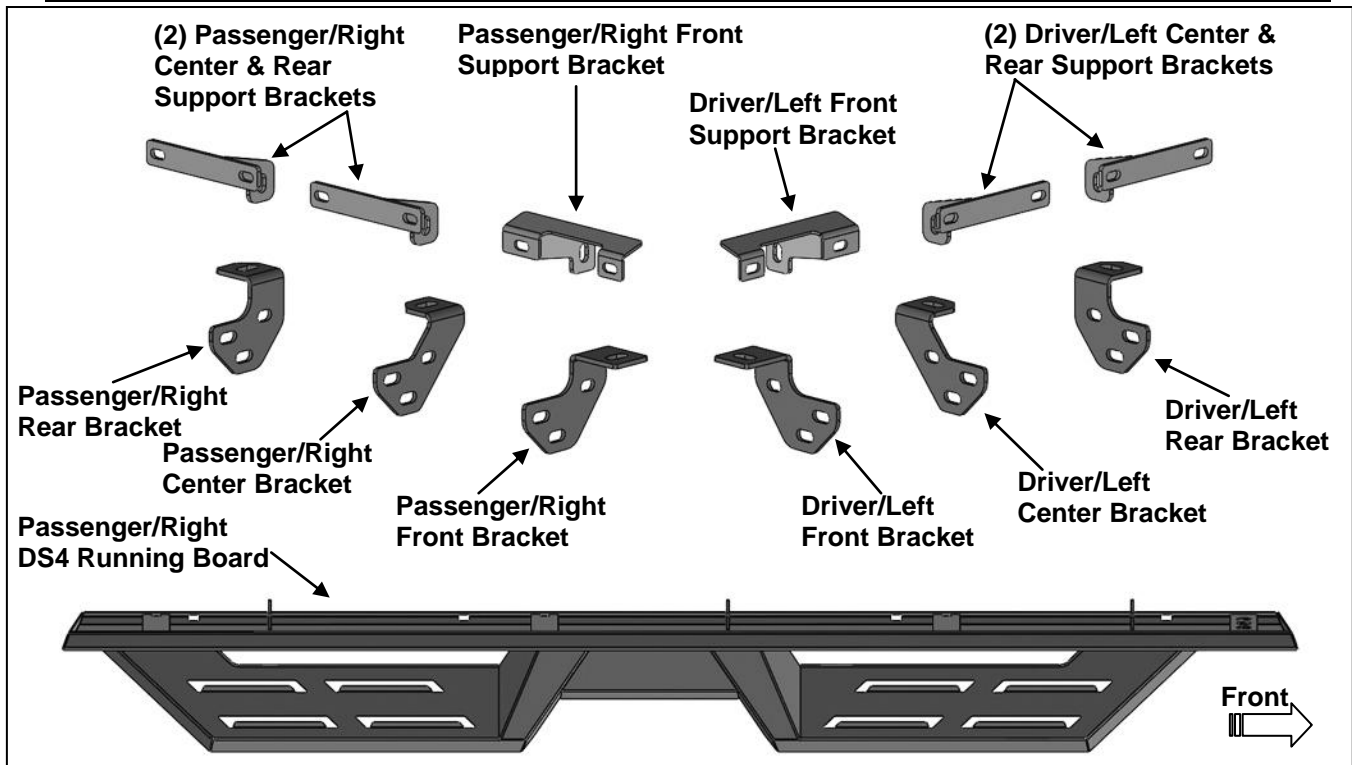

**PROCEDURE:**

- 1. REMOVE CONTENTS FROM BOX. VERIFY ALL PARTS ARE PRESENT. READ INSTRUCTIONS CAREFULLY BEFORE STARTING INSTALLATION. SIDE STEPS OR RUNNING BOARDS MUST BE REMOVED BEFORE INSTALLATION.**
- Start installation on the Passenger/Right front of the vehicle. Find the front threaded insert located in between the first pair of holes along the pinch weld, **(Figure 1)**.
- Select the Passenger/Right Front Mounting Bracket. **IMPORTANT:** Use the illustration above to properly identify the Mounting Bracket. Attach the Mounting Bracket to the threaded insert using (1) 8mm Hex Bolt, (1) 8mm Lock Washer and (1) 8mm Flat Washer, **(Figure 2)**. Do not tighten hardware.
- Select the Passenger/Right Front Support Bracket. **IMPORTANT:** Use the illustration above to help identify the correct Support Bracket. Attach the Support Bracket to the pinch weld using (1) 6mm Double Bolt Plate, (2) 6mm Flat Washers and (2) 6mm Nylon Lock Nuts, **(Figure 3)**. **NOTE: Insert Bolt Plate from the outside of the pinch weld.** Attach the Support Bracket to the Mounting Bracket with (1) 10mm Hex Bolt, (2) 10mm Flat Washers and (1) 10mm Nylon Lock Nut, **(Figures 4 & 5)**. Do not tighten hardware.
- Move to the center mounting location and locate the threaded insert and pair of holes in the pinch weld, **(Figure 6)**. Repeat **Steps 3 & 4** to attach the Passenger/Right Center Mounting Bracket and (1) Center/Rear Support Bracket, **(Figures 2, 3, 6 & 7)**. Do not tighten hardware.

6. Move to the rear mounting location on the rocker panel and locate the threaded insert and pair of holes in the pinch weld, **(Figure 8)**. Repeat **Steps 3 & 4** to attach the Passenger/Right Rear Mounting Bracket and (1) Center/Rear Support Bracket, **(Figures 2, 3 & 9)**. Do not tighten hardware.
7. Select the Passenger/Right DS4 Running Board. Use the illustration above to select the correct Sidebar. With assistance, line up the holes in the mounting tabs on the Running Board to the rear facing slots in the Mounting Brackets. Attach the Running Board to the Mounting Brackets with (6) 10mm Hex Bolts, (12) 10mm Flat Washers and (6) 10mm Nylon Lock Nuts, **(Figures 10 & 11)**. Do not tighten hardware.
8. Level and adjust the DS4 Running Board and tighten all hardware.
9. Repeat **Steps 1—8** for Driver/Left DS4 Running Board installation.
10. Do periodic inspections to the installation to make sure that all hardware is secure and tight.

**To protect your investment**, Do not use any type of polish or wax that may contain abrasives that could damage the finish. Mild soap may be used to clean Running Boards.

### Passenger/Right Side Installation Pictured

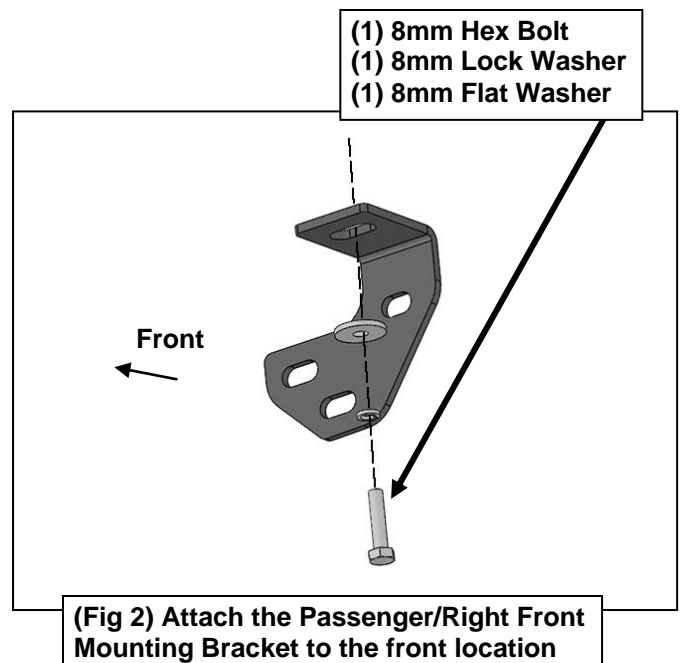
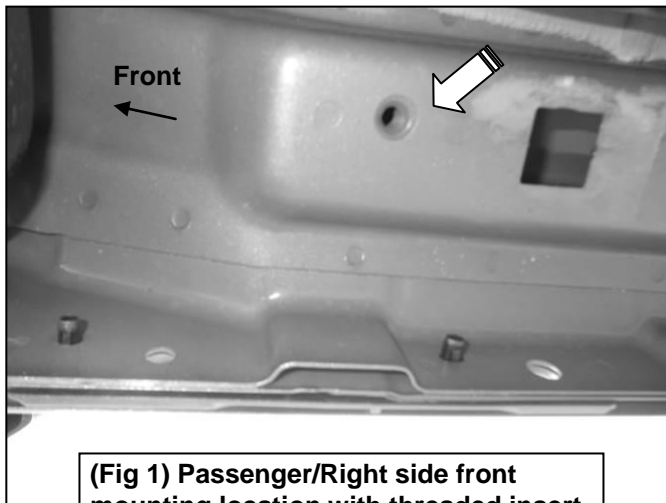

### Passenger/Right Side Installation Pictured

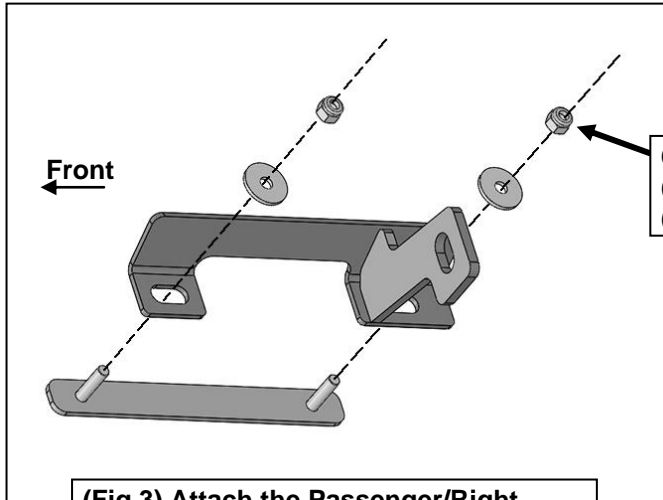

**(Fig 3) Attach the Passenger/Right Front Support Bracket to the pinch trim**

- (1) 10mm Hex Bolt
- (2) 10mm Flat Washers
- (1) 10mm Nylon Lock Nut

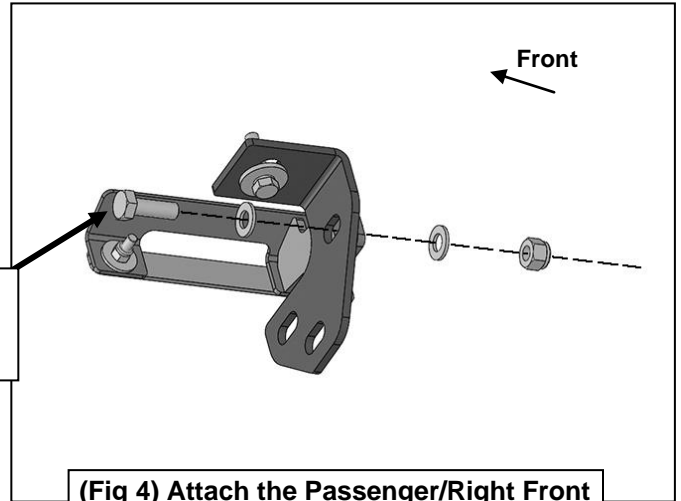

**(Fig 4) Attach the Passenger/Right Front Support Bracket to the pinch weld**

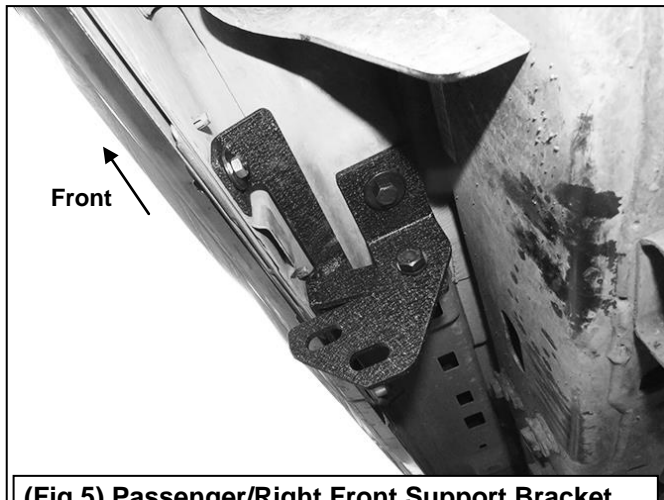

**(Fig 5) Passenger/Right Front Support Bracket attached to the pinch weld and Mounting Bracket**

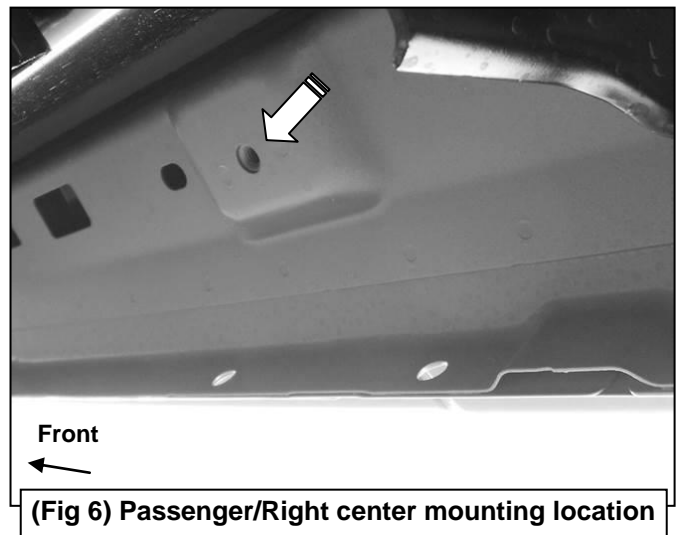

**(Fig 6) Passenger/Right center mounting location**

### Passenger/Right Side Installation Pictured

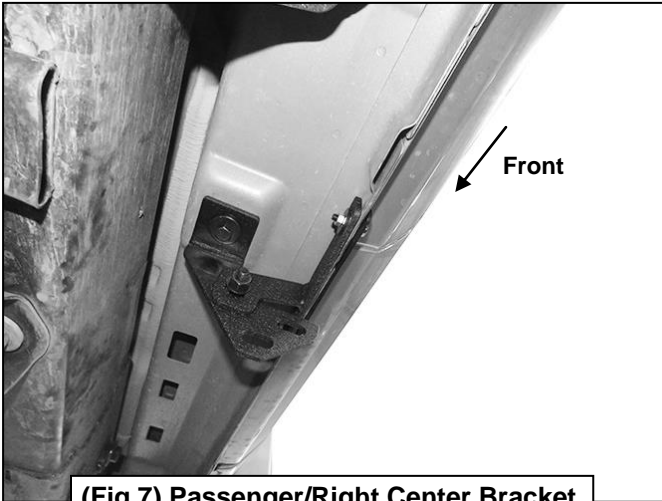

(Fig 7) Passenger/Right Center Bracket attached to Center Support Bracket

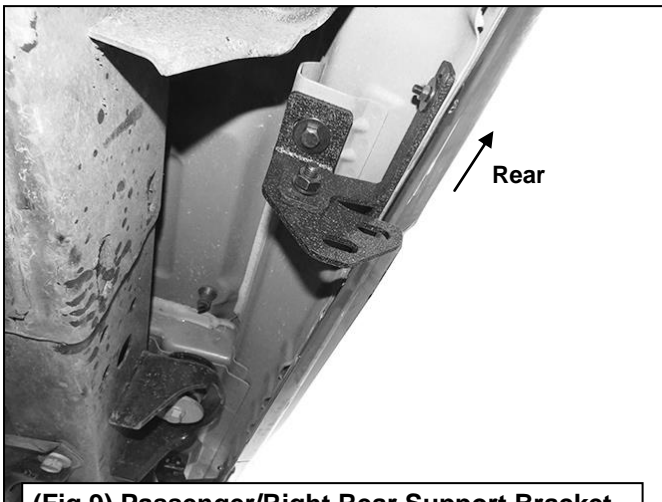

(Fig 9) Passenger/Right Rear Support Bracket attached to pinch weld and Mounting Bracket



(Fig 11) Passenger/Right Running Board attached to the Front Mounting Bracket

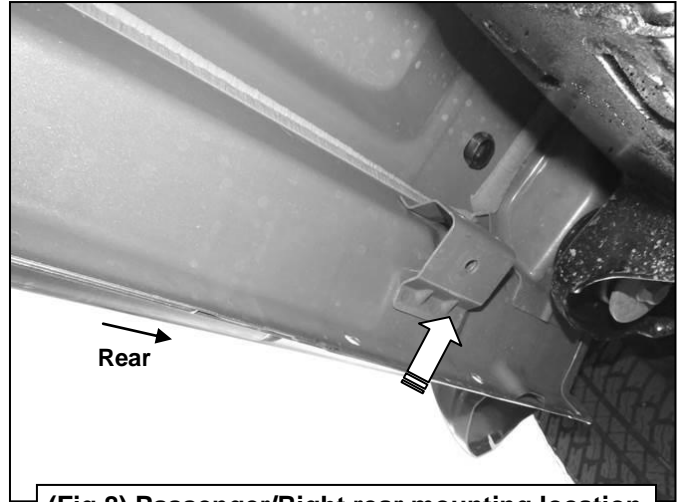

(Fig 8) Passenger/Right rear mounting location

- (2) 10mm Hex Bolts
- (4) 10mm Flat Washers
- (2) 10mm Nylon Lock Nuts

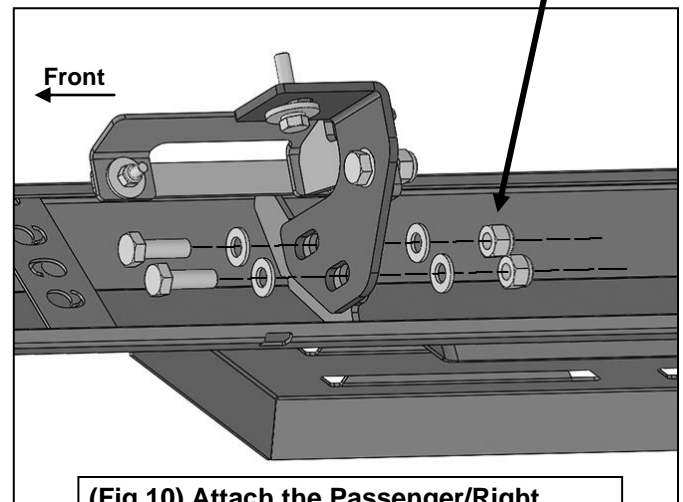

(Fig 10) Attach the Passenger/Right Running Board to the Mounting Brackets