

**P1 PLASTIC MOLDED RUNNING BOARDS
99-16 FORD F-250/350/450/550 SUPER CAB/SUPER CREW CAB**

PARTS LIST:

2	P1 Molded Running Boards	6	8-1.25mm Nylon Lock Nuts
6	Universal Mounting Brackets (left of right)	6	6mm Double Bolt Plates
6	8-1.25mm Clip-Nuts	12	6mm x 22mm x 2mm Flat Washers
12	8-1.25mm x 25mm Hex Bolts	12	6mm Lock Washers
18	8mm x 24mm x 2mm Flat Washer	12	6mm Hex Nuts
6	8mm Lock Washers		

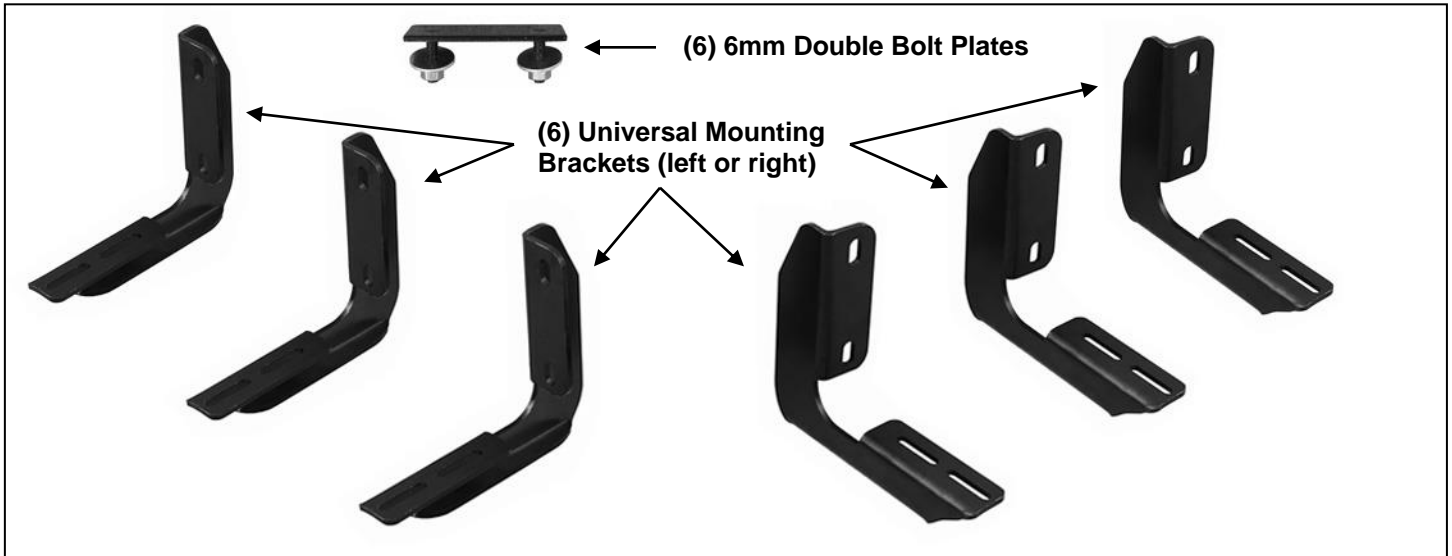

PROCEDURE:

- 1. REMOVE CONTENTS FROM BOX. VERIFY ALL PARTS ARE PRESENT. READ INSTRUCTIONS CAREFULLY BEFORE STARTING INSTALLATION.**
- Starting on the front-driver side of the vehicle, locate the (2) holes through the bottom of the body panel, (pinch weld-**Figure 1A**). Next locate the rectangular opening and the small hole in the inner body panel directly above the holes in the pinch weld, (**Figures 1B & 2**). **NOTE:** The holes in the inner panel may be covered with sealing tape or insulation, remove as required.
- Slide (1) 8mm Clip Nut into the rectangular opening with the nut towards the inside. Line up the threaded nut on the clip with the round hole toward the rear, (**Figure 2**).
- Select (1) Mounting Bracket. Attach the top of the Bracket to the Clip Nut with (1) 8mm x 25mm Hex Bolt, (1) 8mm Lock Washer and (1) 8mm Flat Washer, (**Figure 3**). Leave loose at this time. Line up the lower hole in the Bracket with the hole through the pinch weld. Bolt the Bracket to the pinch weld with (1) 8mm x 25mm Hex Bolt, (2) 8mm Flat Washers and (1) 8mm Nylon Lock Nut, (**Figure 3**). Snug but do not fully tighten Bracket hardware.
- Move to the center mounting location, (**Figure 4**). **NOTE:** There are (4) factory mounting locations along the inner body panel. Installation will use the 1st, 3rd and 4th mounting locations only. Refer to **Figures 1A & 1B** to help identify the correct locations. Repeat **Steps 2—4** to install the center Bracket in the front set of mounting holes, (**Figure 5**).
- Move toward the rear of the cab. Locate the last pair of holes along the pinch weld. Use **Figure 1B** to determine the correct mounting location for the rear Bracket. Repeat **Steps 2—4** to install (1) Mounting Bracket in the front pair of holes in the rear location, (**Figure 6**).
- Once the (3) Brackets have been fully installed, select (1) P1 Running Board. Place the Running Board on top of the Brackets. Locate the channels in the bottom of the Running Board. Select (3) 6mm Double Bolt Plates, (**Figure 7**). Insert the Bolt Plates into the channels in the bottom of the Running Board closest to the Brackets, (**Figure 8**). Lift the Board up and guide the studs through the Brackets.
- Attach the Running Board to the Brackets with (6) 6mm Flat Washers, (6) 6mm Lock Washers and (6) 6mm Hex Nuts, (**Figure 9**).

**P1 PLASTIC MOLDED RUNNING BOARDS
99-16 FORD F-250/350/450/550 SUPER CAB/SUPER CREW CAB**

9. Level and adjust the Running Board as necessary and fully tighten all hardware.
10. Repeat **Steps 2—9** for passenger side Running Board installation.
11. Do periodic inspections to the installation to make sure that all hardware is secure and tight.

To protect your investment, wax this product after installing. Regular waxing is recommended to add a protective layer over the finish. Do not use any type of polish or wax that may contain abrasives that could damage the finish. Mild soap may be used to clean the P1 Running Board.

Driver/left Side Installation Pictured

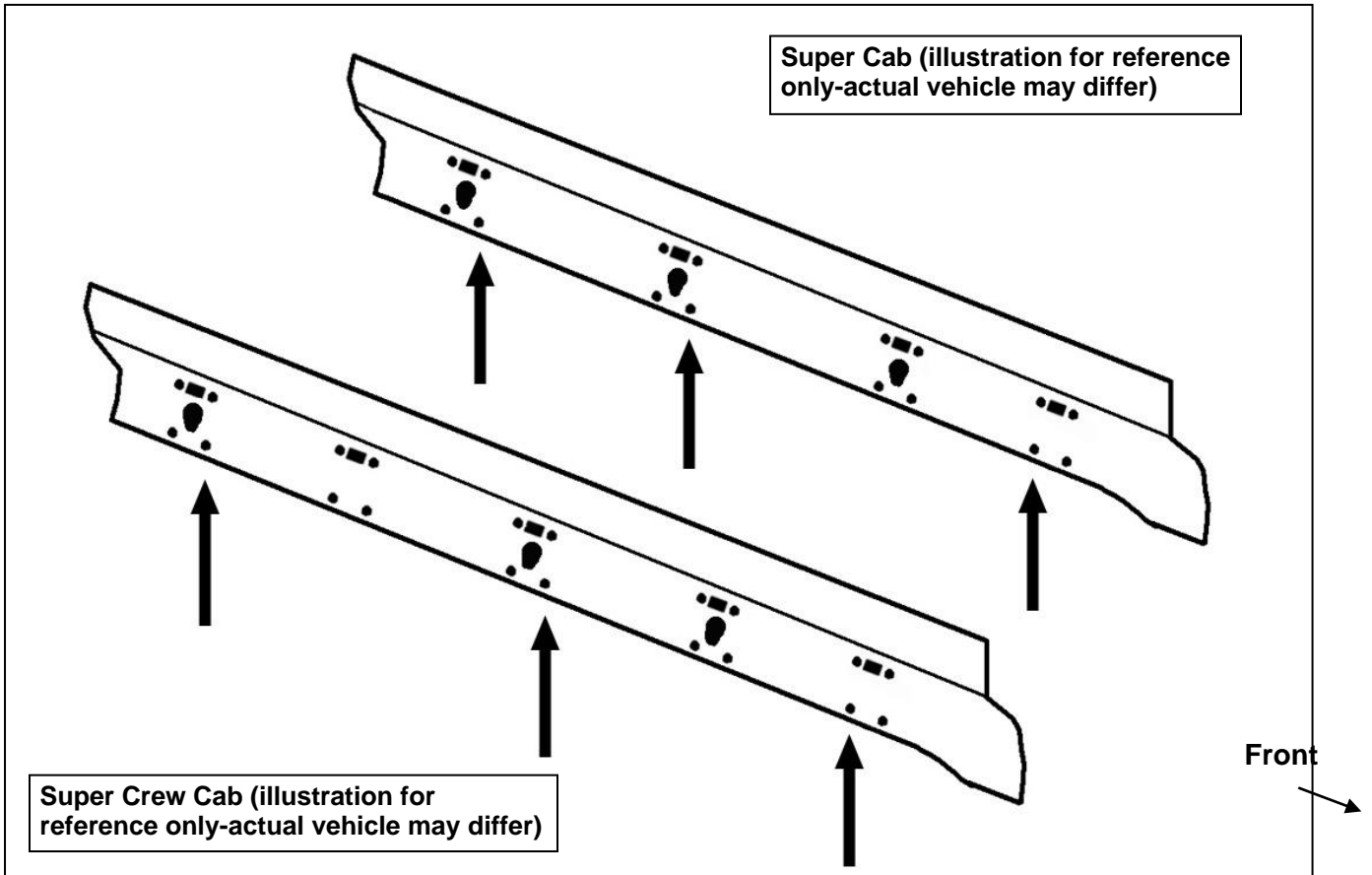

(Fig 1) Driver/left side mounting area illustrated for instruction purposes only

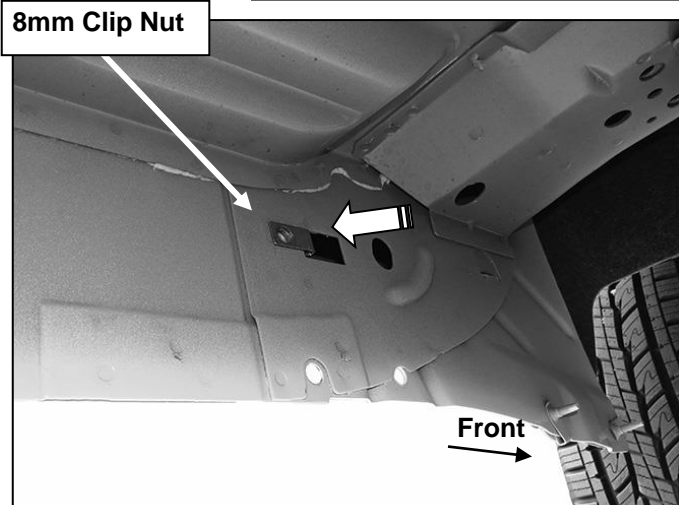

(Fig 2) Slide 8mm Clip Nut into rectangular opening

Driver/left Side Installation Pictured

**P1 PLASTIC MOLDED RUNNING BOARDS
99-16 FORD F-250/350/450/550 SUPER CAB/SUPER CREW CAB**

8mm Clip Nut
8mm x 25mm Hex Bolt
8mm Lock Washer
8mm Flat Washer

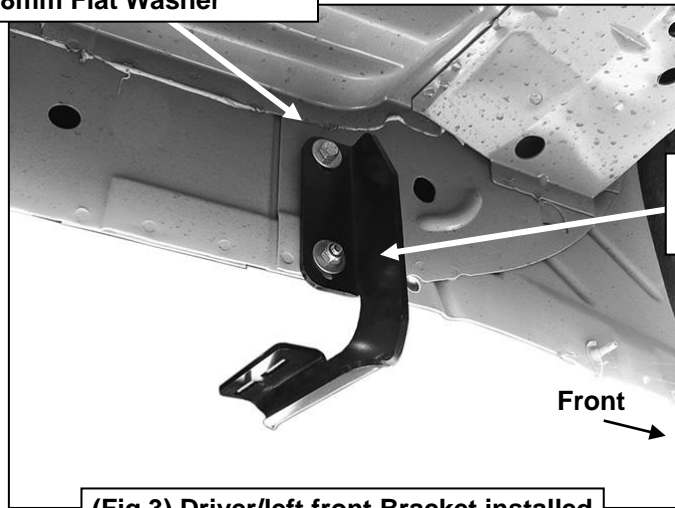

(Fig 3) Driver/left front Bracket installed

8mm x 25mm Hex Bolt
(2) 8mm Flat Washers
8mm Nylon Lock Nut

8mm Clip Nut

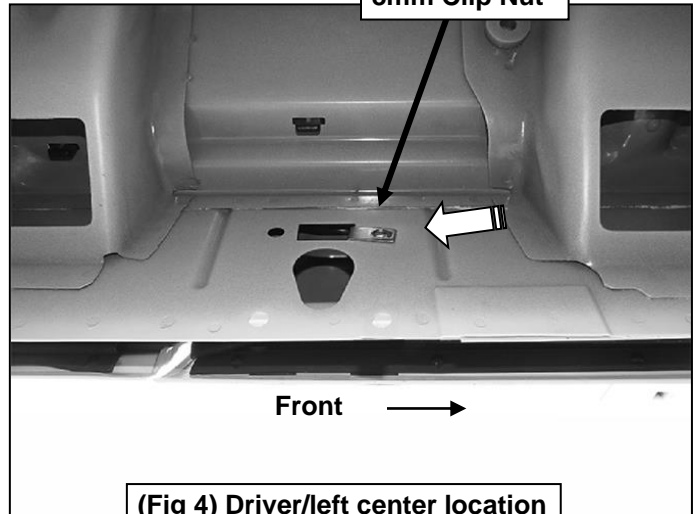

(Fig 4) Driver/left center location

8mm Clip Nut
8mm x 25mm Hex Bolt
8mm Lock Washer
8mm Flat Washer

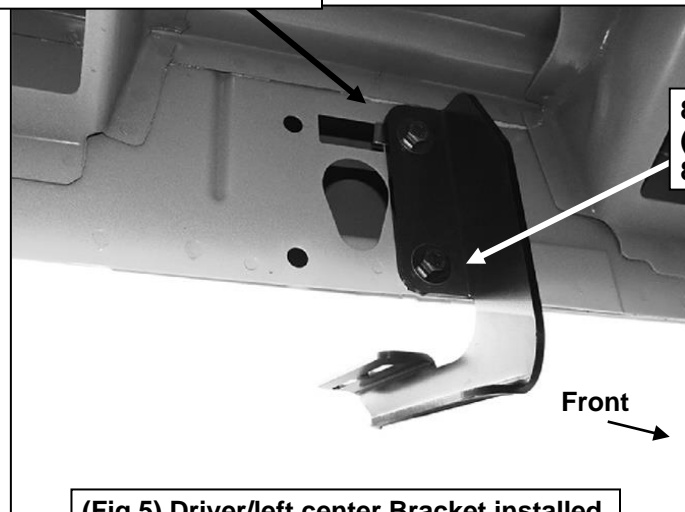

(Fig 5) Driver/left center Bracket installed

8mm x 25mm Hex Bolt
(2) 8mm Flat Washers
8mm Nylon Lock Nut

8mm Clip Nut

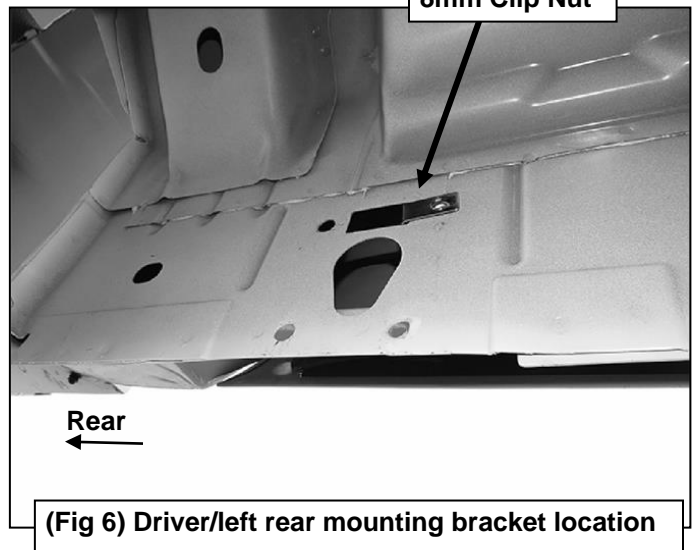

(Fig 6) Driver/left rear mounting bracket location

Driver/left Side Installation Pictured

**P1 PLASTIC MOLDED RUNNING BOARDS
99-16 FORD F-250/350/450/550 SUPER CAB/SUPER CREW CAB**

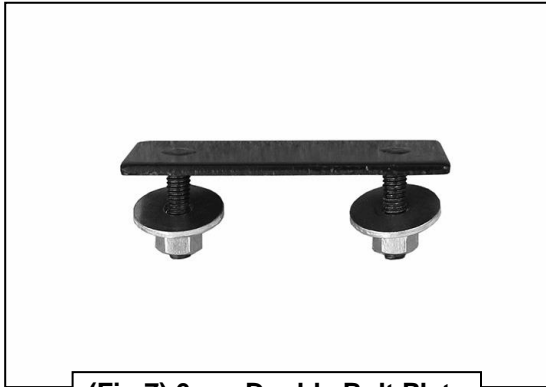

(Fig 7) 6mm Double Bolt Plate

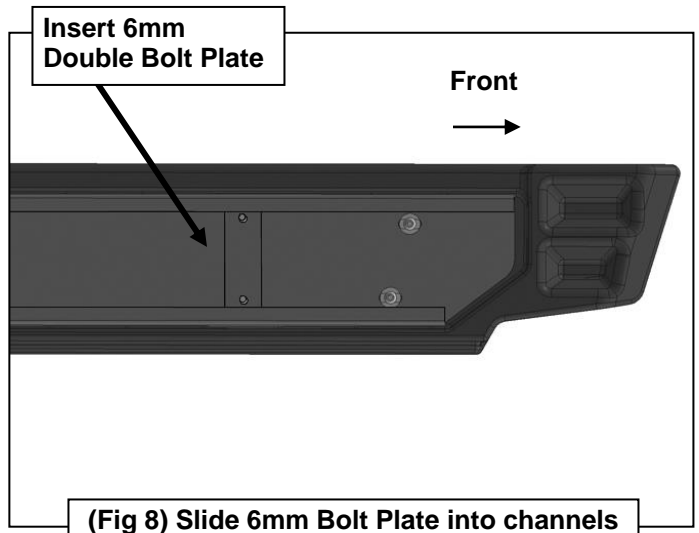

(Fig 8) Slide 6mm Bolt Plate into channels

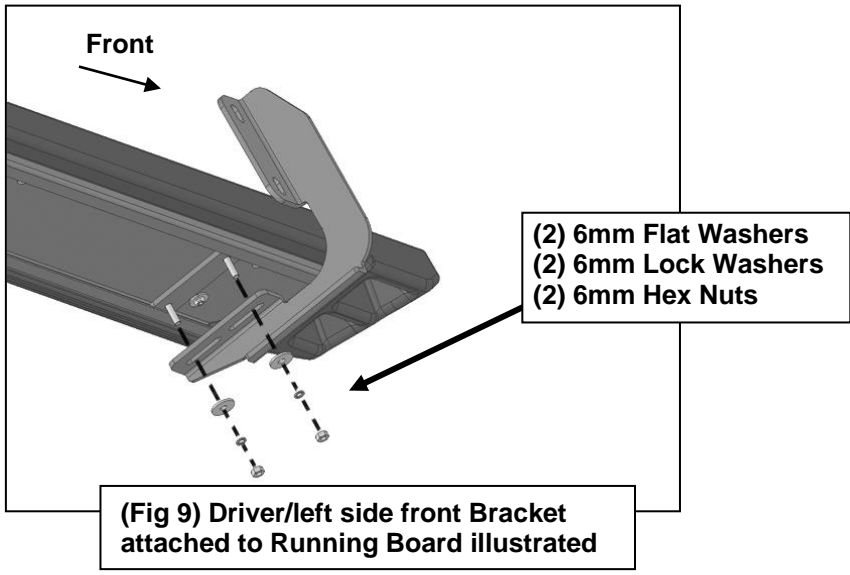

(Fig 9) Driver/left side front Bracket attached to Running Board illustrated