

**P1 PLASTIC MOLDED RUNNING BOARD
09-14 FORD F-150 SUPERCREW**

PARTS LIST:

2	78" P1 Plastic Running Boards	12	8mm Lock Washers
4	Front or Rear Mounting Brackets	6	6mm Double Bolt Plates
2	Center Mounting Brackets	12	6mm x 22mm x 2mm Flat Washers
12	8mm Deep Clip Nuts	12	6mm Lock Washers
12	8-1.25mm x 25mm Hex Bolts	12	6mm Hex Nuts
12	8mm x 24mm x 2mm Flat Washers		

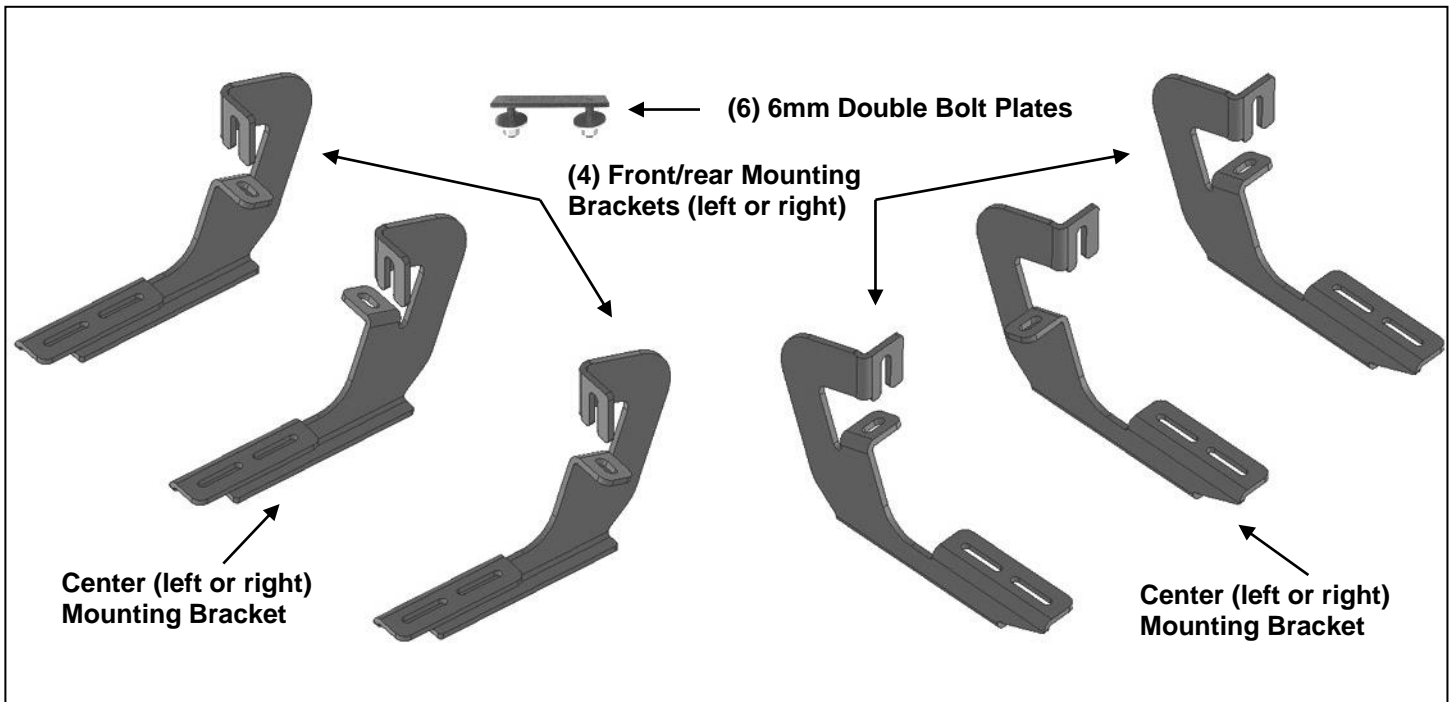

PROCEDURE:

- 1. REMOVE CONTENTS FROM BOX. VERIFY ALL PARTS ARE PRESENT. READ INSTRUCTIONS CAREFULLY BEFORE STARTING INSTALLATION.**
- Starting on the driver side of the vehicle, locate the (2) holes in the bottom of the body panel, (through pinch weld). Next locate the rectangular opening and (2) small holes in the inner body panel directly above the holes in the pinch weld, **(Figures 1 & 2)**. Front Bracket installation will use only the forward mounting holes. **NOTE:** The holes in the inner panel may be covered with sealing tape or insulation.
- Slide (1) 8mm Clip Nut into the rectangular opening with the nut towards the inside. Line up the threaded nut on the clip with the round hole toward the front of the vehicle, **(Figure 2)**. Repeat to install an 8mm Clip Nut in forward hole in the pinch weld. **NOTE:** If necessary, hold a mounting Bracket up in position to determine correct factory mounting holes to use.
- Select (1) Front/rear mounting Bracket, **(Figure 3)**. Attach the Bracket to the (2) Clip Nuts with the included (2) 8mm Hex Bolts, (2) 8mm Lock Washers and (2) 8mm Flat Washers, **(Figure 4)**. Depending on model and year, the brake cable may be run on the inside or outside of the Bracket. Do not tighten hardware at this time. **IMPORTANT:** The (6) Brackets look similar but the (2) center Brackets are unique, **(Figure 6)**. Separate the (2) Center Brackets from the (4) Front/Rear Brackets, **(Figure 3)**.
- Next, move toward the center of the vehicle. Locate the (2) holes in the pinch weld similar to the front location, **(Figures 1 & 5)**. Locate the rectangular slot and single round hole. Repeat **Steps 2—4** to install the driver side Center Bracket, **(Figures 6 & 7)**.
- Continue along the cab to the rear mounting location. Locate the last (2) mounting holes in the pinch weld towards the back of the cab, **(Figures 1 & 8)**. Repeat **Steps 2—4** to install a Front/Rear mounting Bracket in the forward mounting location, **(Figures 3 & 8)**.
- Carefully unwrap and select the driver side Running Board. Place the Running Board on top of the Brackets.

**P1 PLASTIC MOLDED RUNNING BOARD
09-14 FORD F-150 SUPERCREW**

8. Select (3) 6mm Double Bolt Plates, **(Figure 9)**. Locate the channels in the bottom of the Running Board. Insert the Bolt Plates into the channels in the bottom of the Running Board closest to the Brackets **(Figure 10)**. Lift the Running Board up and guide the studs through the Brackets.
9. Attach the Running Board to the Brackets with (6) 6mm Flat Washers, (6) 6mm Lock Washers and (6) 6mm Hex Nuts, **(Figure 11)**. **NOTE:** The Running Board is designed to fit close to the vehicle. It may be necessary to loosen the Bracket hardware and tilt the Brackets downward to insert the Running Board between the Brackets and the body. Do not tighten hardware at this time.
10. Level and adjust the Running Board as desired and tighten all hardware.
11. Repeat **Steps 2—10** for the passenger side Running Board installation. **NOTE:** Brackets will install “reversed” from pictured when installed on passenger side.
12. Do periodic inspections to the installation to make sure that all hardware is secure and tight.

To protect your investment, wax this product after installing. Regular waxing is recommended to add a protective layer over the finish. Do not use any type of polish or wax that may contain abrasives that could damage the finish.
For black powder coated finishes: Mild soap may be used to clean the Running Board.

Driver Side Installation Pictured

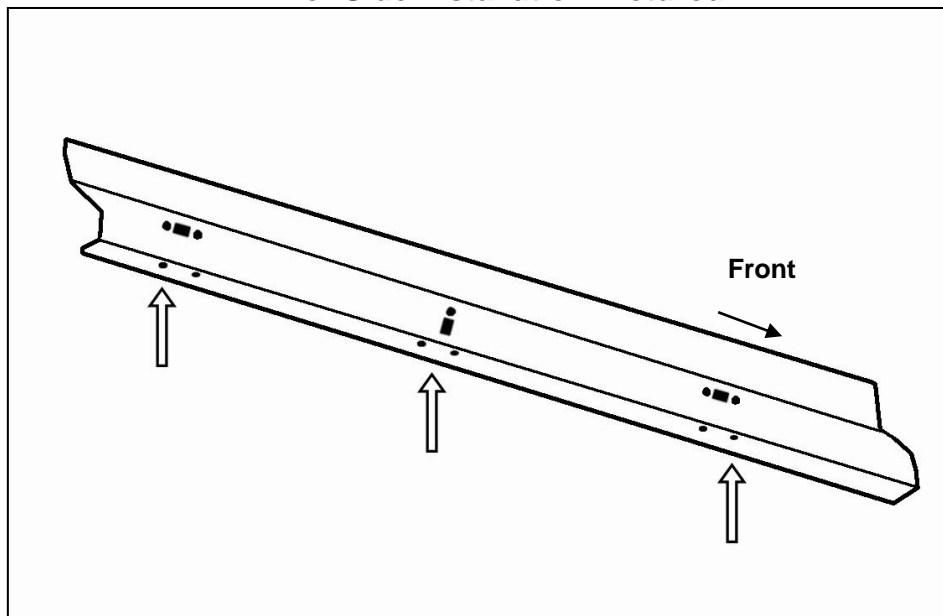

(Fig 1) Driver/left mounting locations illustrated from back of rocker panel

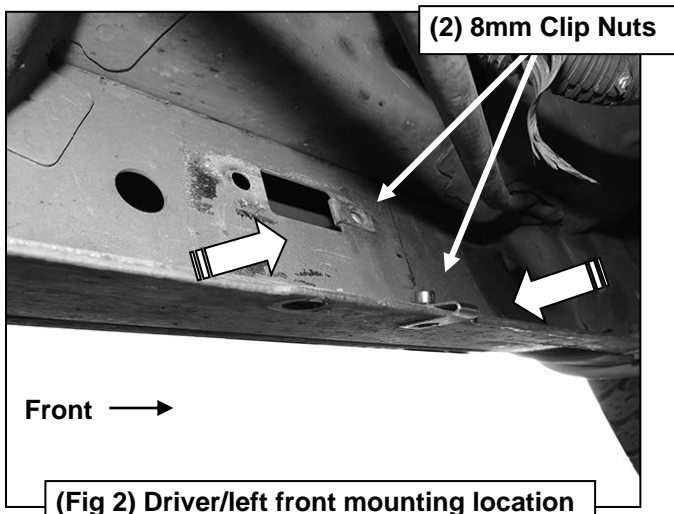

(Fig 2) Driver/left front mounting location

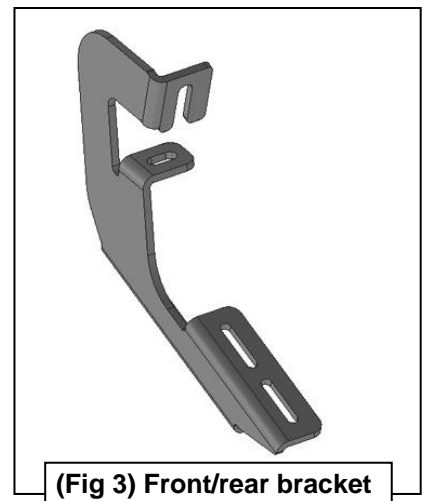

(Fig 3) Front/rear bracket

Driver Side Installation Pictured

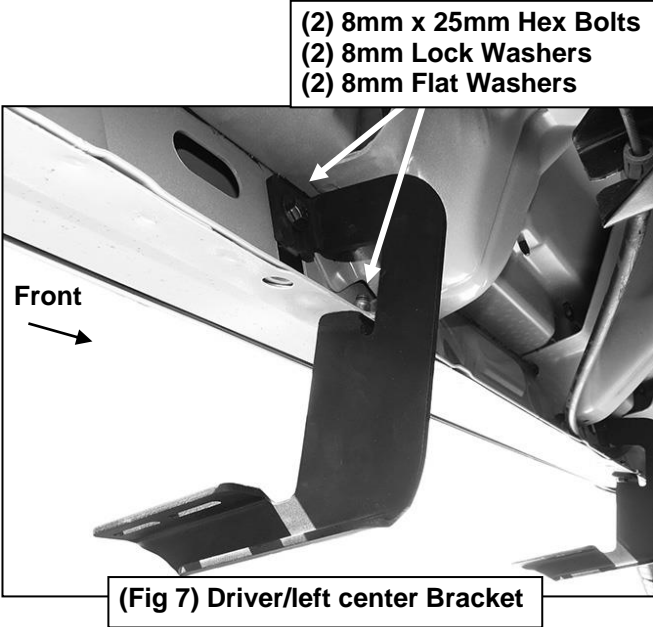
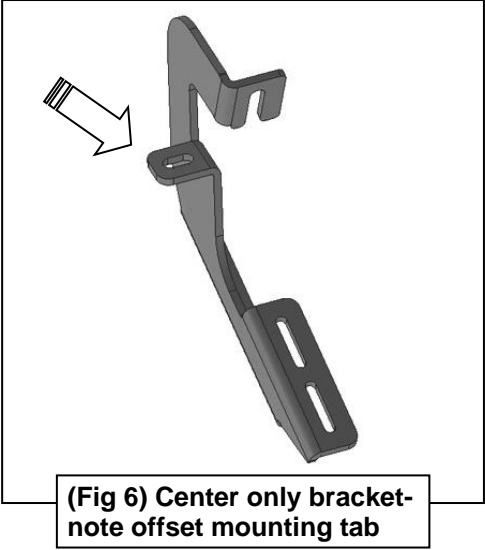
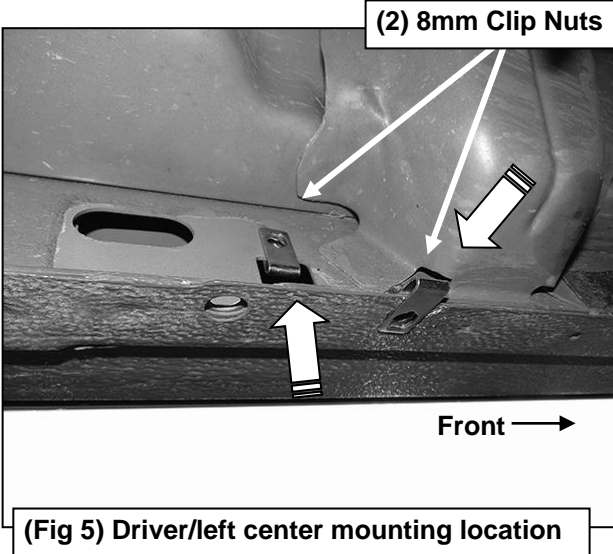
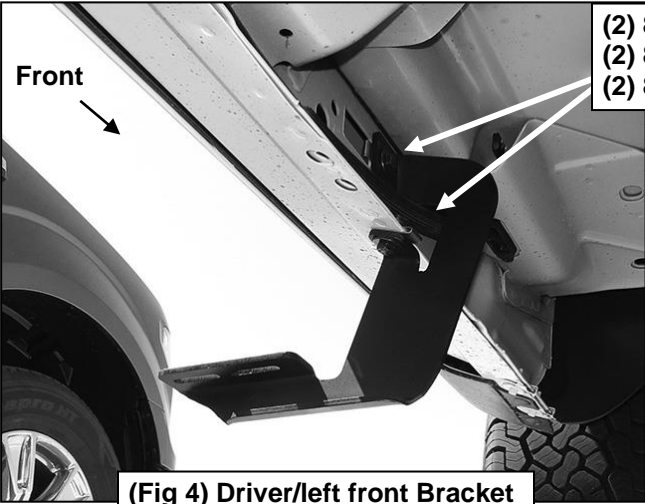

Driver Side Installation Pictured

