

**P1 PLASTIC MOLDED RUNNING BOARDS
09-14 FORD F-150 SUPER CAB**

PARTS LIST:

2	78" P1 Molded Running Boards	12	8mm x 24mm x 2mm Flat Washers
6	Universal Mounting Brackets	6	6mm Double Bolt Plates
12	8mm Deep Clip Nuts	12	6mm x 22mm x 2mm Flat Washers
12	8-1.25mm x 25mm Hex Bolts	12	6mm Lock Washers
12	8mm Lock Washers	12	6mm Hex Nuts

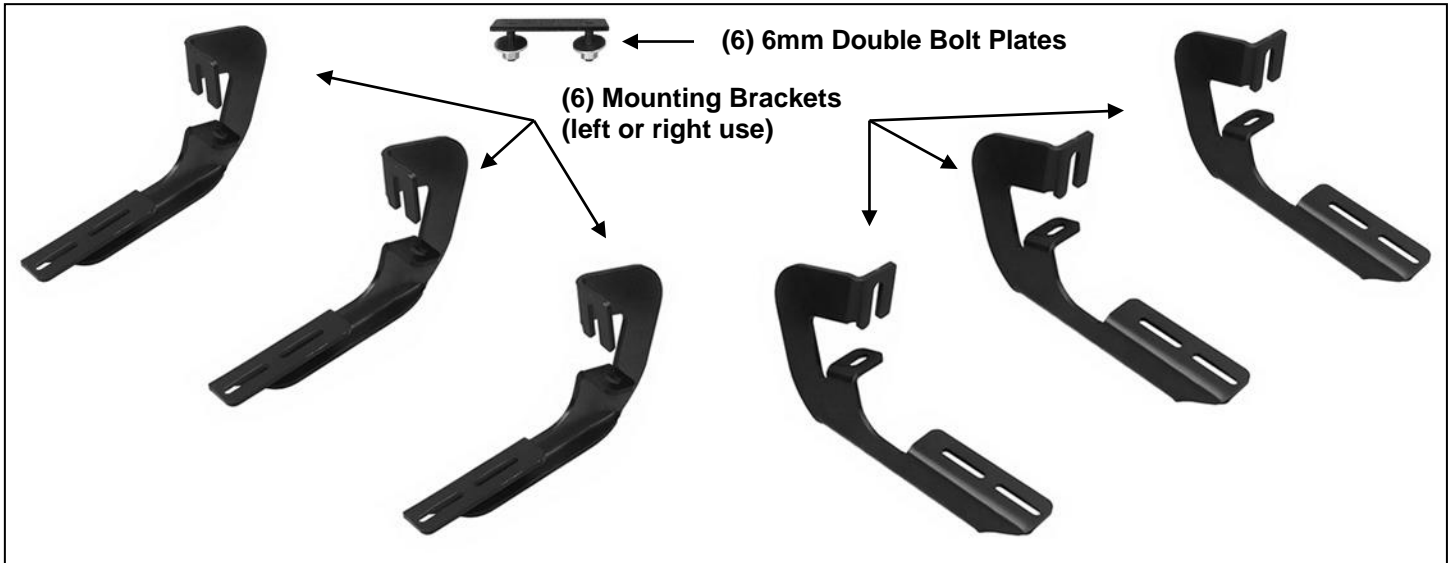

PROCEDURE:

REMOVE CONTENTS FROM BOX. VERIFY ALL PARTS ARE PRESENT. READ INSTRUCTIONS CAREFULLY BEFORE STARTING INSTALLATION.

- Starting on the driver side of the vehicle, locate the (2) holes in the bottom of the body panel, (pinch weld). Next locate the rectangular opening and (2) small holes in the inner body panel directly above the holes in the pinch weld, **(Figures 1 & 2)**. Installation will use only the forward holes in the front, center and rear mounting locations. **NOTE:** The holes in the inner panel may be covered with sealing tape or insulation, remove as required.
- Slide (1) 8mm Clip Nut into the rectangular opening with the nut towards the inside. Line up the threaded nut on the clip with the round hole toward the front of the vehicle, **(Figure 2)**. Repeat to install an 8mm Clip Nut in forward hole in the pinch weld. **NOTE:** If necessary, hold a mounting Bracket up in position to determine correct factory mounting holes to use.
- Attach the Mounting Bracket to the (2) Clip Nuts with the included (2) 8mm Hex Bolts, (2) 8mm Lock Washers and (2) 8mm Flat Washers, **(Figure 3)**. Depending on model and year, the brake cable may be run on the inside or outside of the Bracket. Do not tighten hardware.
- Next, move toward the center of the vehicle. Locate the (2) holes in the pinch weld similar to the front location, **(Figures 1 & 4)**. Repeat **Steps 1—3** to install a Bracket in the center mounting location, **(Figure 5)**.
- Continue along the cab to the rear mounting location. Locate the last (2) mounting holes in the pinch weld towards the back of the cab, **(Figures 1 & 6)**. Repeat **Steps 1—3** to install the rear mounting Bracket, **(Figure 6)**.
- Carefully unwrap (1) P1 Running Board. Place the Running Board on top of the Brackets. Locate the channels in the bottom of the Running Board. Select (3) 6mm Double Bolt Plates. Insert the Bolt Plates into the channels in the bottom of the Running Board closest to the

**P1 PLASTIC MOLDED RUNNING BOARDS
09-14 FORD F-150 SUPER CAB**

Brackets, **(Figure 7)**. Lift the Running Board up and guide the studs down through the Brackets.

7. Attach the Running Board to the Mounting Brackets with the included (6) 6mm Flat Washers, (6) 6mm Lock Washers and (6) 6mm Hex Nuts, **(Figure 8)**. Do not tighten at this time.
8. Level and adjust the P1 Running Board as desired and tighten all hardware.
9. Repeat **Steps 1—8** for the passenger side Running Board installation.
10. Do periodic inspections to the installation to make sure that all hardware is secure and tight.

To protect your investment, wax this product after installing. Regular waxing is recommended to add a protective layer over the finish. Do not use any type of polish or wax that may contain abrasives that could damage the finish. Mild soap may be used to clean the P1 Running Board.

Driver Side Installation Pictured

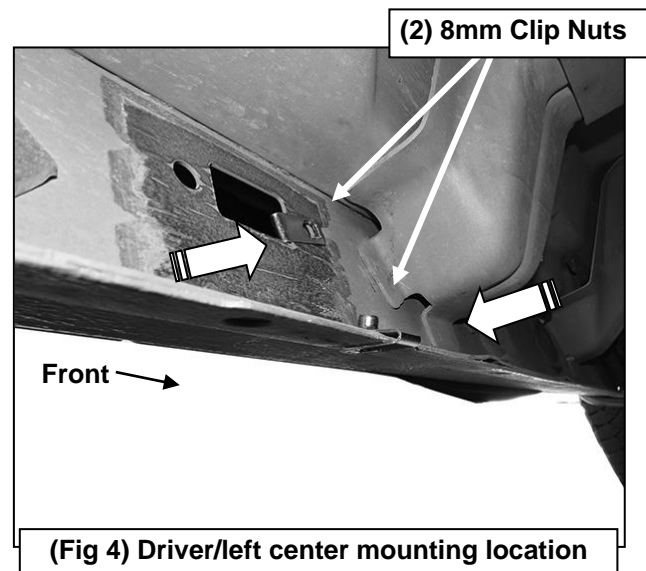
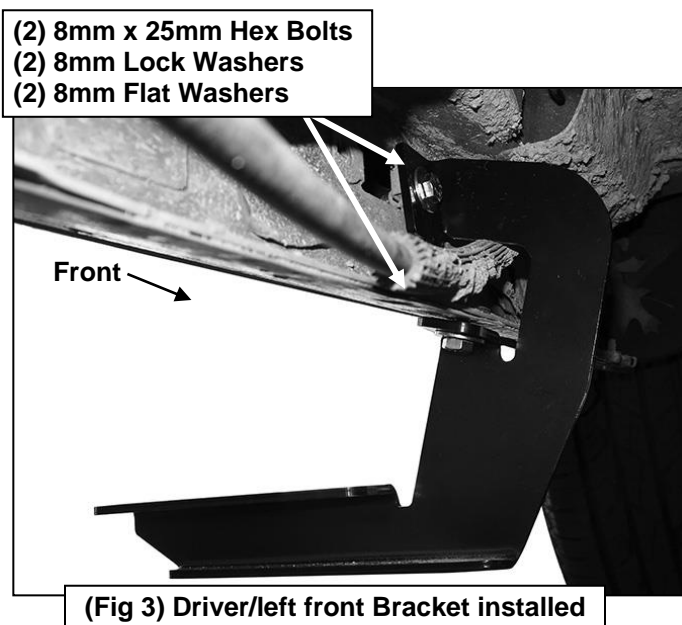
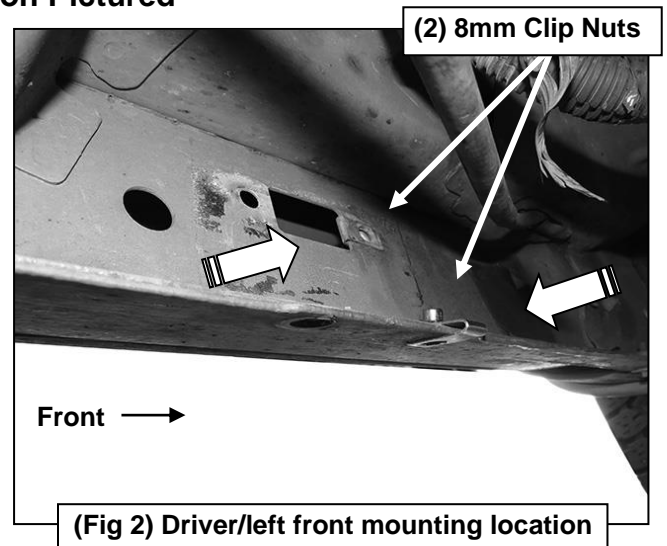
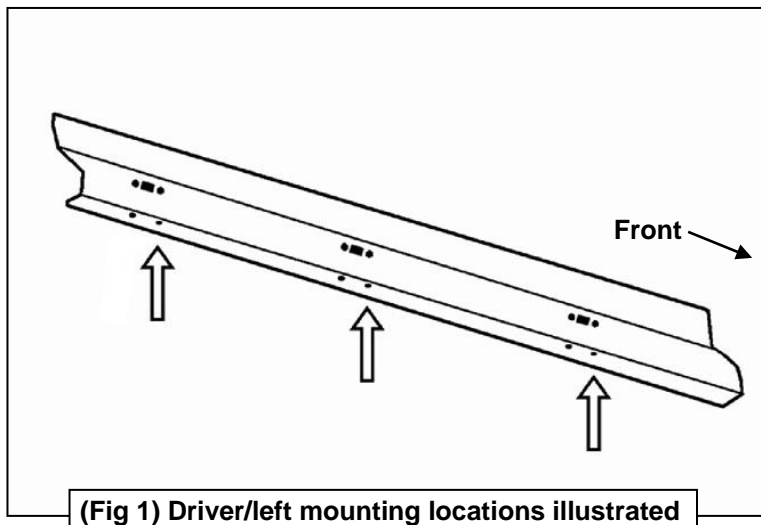

Driver Side Installation Pictured

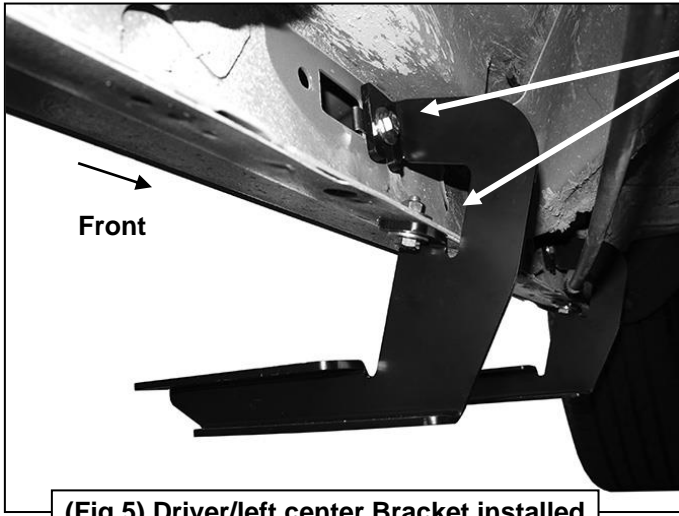

- (2) 8mm x 25mm Hex Bolts
- (2) 8mm Lock Washers
- (2) 8mm Flat Washers

(Fig 5) Driver/left center Bracket installed

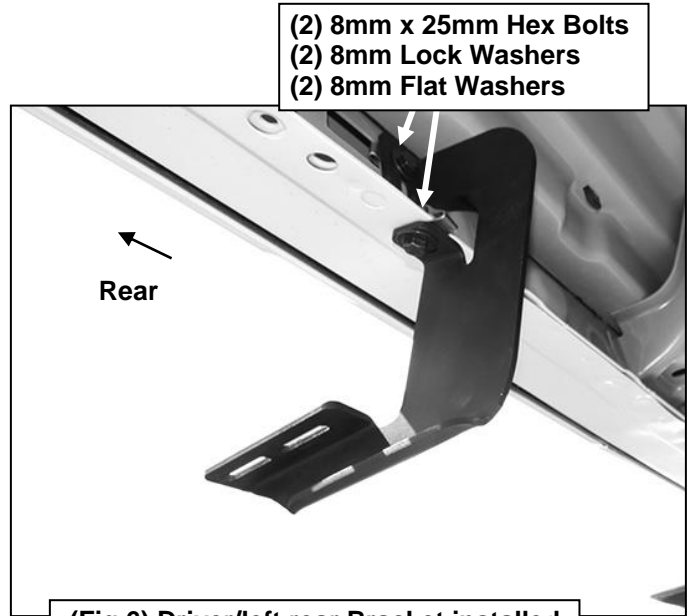

- (2) 8mm x 25mm Hex Bolts
- (2) 8mm Lock Washers
- (2) 8mm Flat Washers

(Fig 6) Driver/left rear Bracket installed

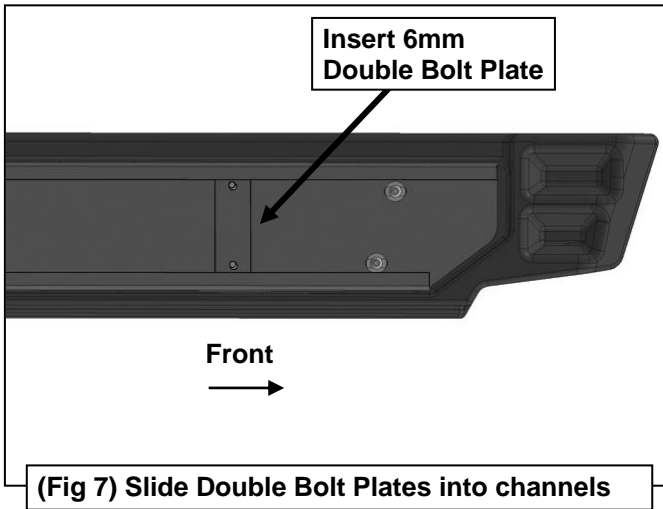

(Fig 7) Slide Double Bolt Plates into channels

