

PARTS LIST:

2	91" S6 Running Boards	12	8mm Clip Nuts
6	Mounting Brackets	24	8mm Lock Washers
6	8-1.25mm x 35mm Double Bolt Plates	12	8-1.25mm Nylon Lock Nuts
24	8-1.25mm x 30mm Hex Bolts	12	8-1.25mm Hex Nuts
48	8mm x 24mm x 2mm Flat Washers		

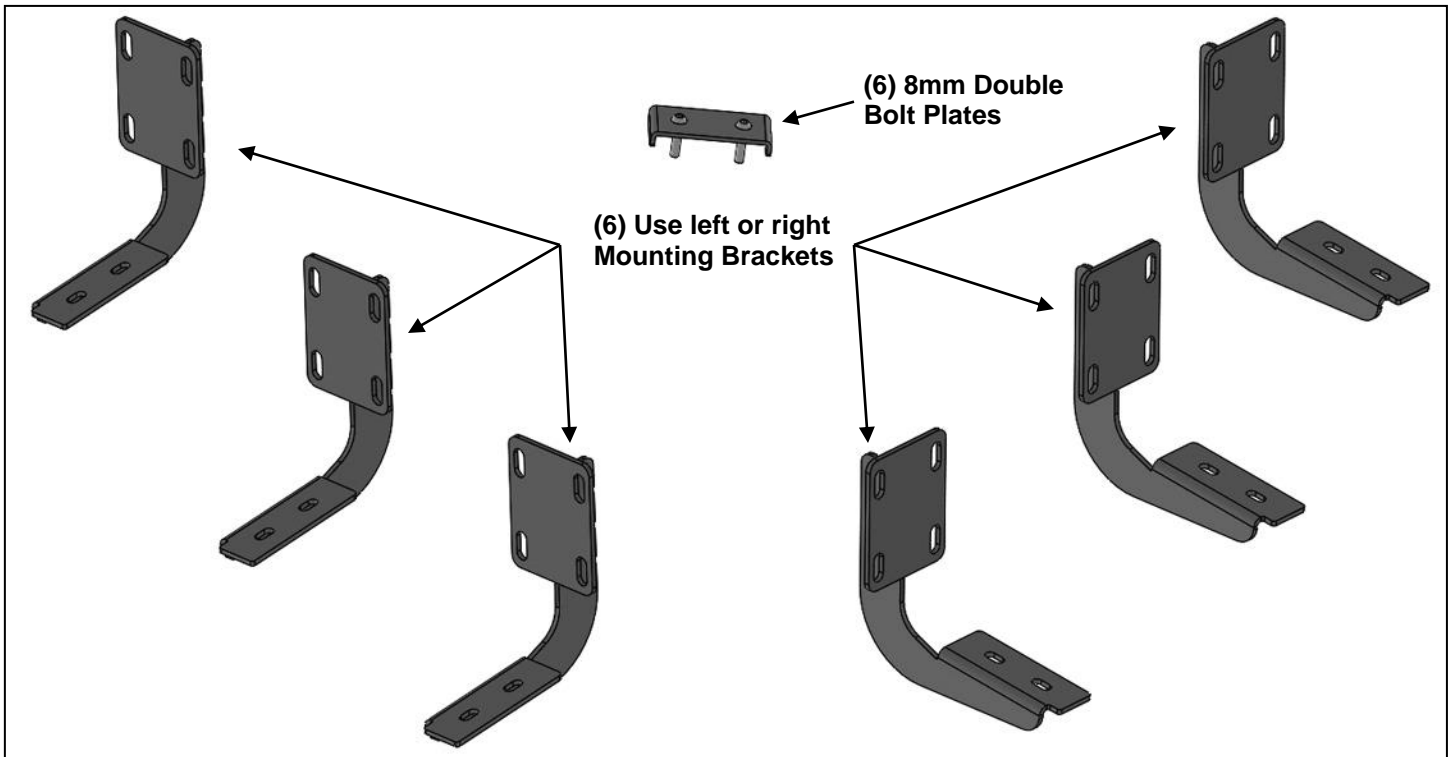

PROCEDURE:

- 1. REMOVE CONTENTS FROM BOX. VERIFY ALL PARTS ARE PRESENT. READ INSTRUCTIONS CAREFULLY BEFORE STARTING INSTALLATION.**
- Starting on the driver front side of the vehicle, locate the (2) holes through the bottom of the pinch weld. Next, locate the rectangular opening and the (2) small hole in the inner body panel directly above the holes in the pinch weld, **(Figures 1 & 2)**. **NOTE:** The holes in the inner panel may be covered with sealing tape or insulation, remove as required.
- Slide (2) 8mm "U" Clips into the rectangular opening with the nut towards the inside. Line up the threaded nut on the clips with the (2) small round holes, **(Figure 3)**.
- Select (1) Mounting Bracket. Attach the top of the Bracket to the "U" Clips with (2) 8mm Hex Bolts, (2) 8mm Lock Washers and (2) 8mm Flat Washers, **(Figures 4 & 5)**. Line up the lower holes in the Bracket with the (2) holes through the pinch weld. Bolt the Bracket to the pinch weld with (2) 8mm Hex Bolts, (4) 8mm Flat Washers, (2) 8mm Lock Washers and (2) 8mm Hex Nuts, **(Figures 4 & 5)**. Snug but do not fully tighten Bracket hardware.
- Move toward the center of the cab, **(Figure 6)**. Locate the pair of holes along the pinch weld. Use **Figure 1** to determine the correct mounting location for the center Bracket. Repeat **Steps 2—4** to install (1) Mounting Bracket on the center location.
- Move toward the rear of the cab, **(Figure 7)**. Locate the last pair of holes along the pinch weld. Use **Figure 1** to determine the correct mounting location for the rear Bracket. Repeat **Steps 2—4** to install (1) Driver side Mounting Bracket on the rear location, **(Figure 8)**.
- Once the (3) Brackets have been fully installed, select (1) Running Board. Place the Running Board on top of the Brackets. Locate the channel in the bottom of the Running Board. Select (3) 8mm Double Bolt Plates, **(Figure 9)**. Insert the Bolt Plates into the channel in the bottom of the Running Board closest to the Brackets, **(Figure 10)**. Lift the Board up and guide the studs through the Brackets.

8. Attach the Running Board to the Brackets with (6) 8mm Flat Washers and (6) 8mm Nylon Lock Nuts, (Figures 11—13).
9. Level and adjust the Running Board as necessary and fully tighten all hardware.
10. Repeat **Steps 2—8** for passenger side Running Board installation.
11. Do periodic inspections to the installation to make sure that all hardware is secure and tight.

To protect your investment, wax this product after installing. Regular waxing is recommended to add a protective layer over the finish. Do not use any type of polish or wax that may contain abrasives that could damage the finish. Mild soap may be used to clean the Running Board.

Driver Side Installation Pictured

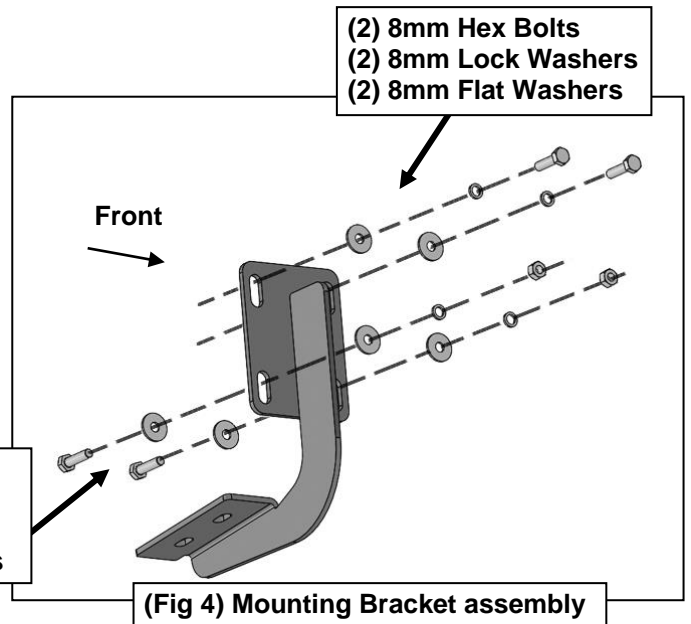
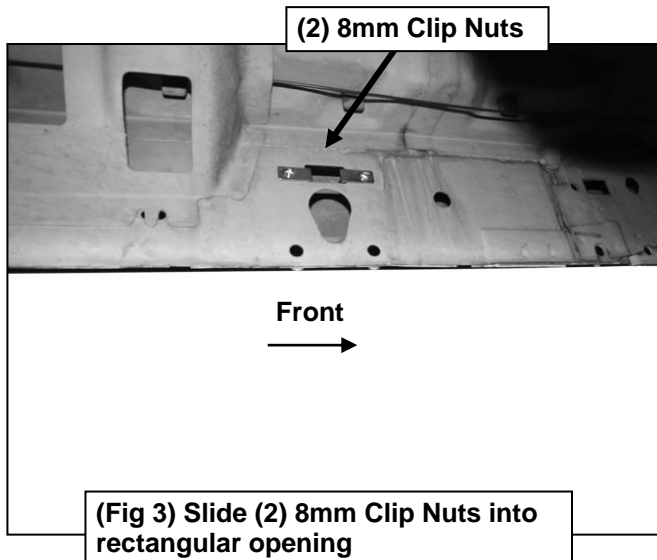
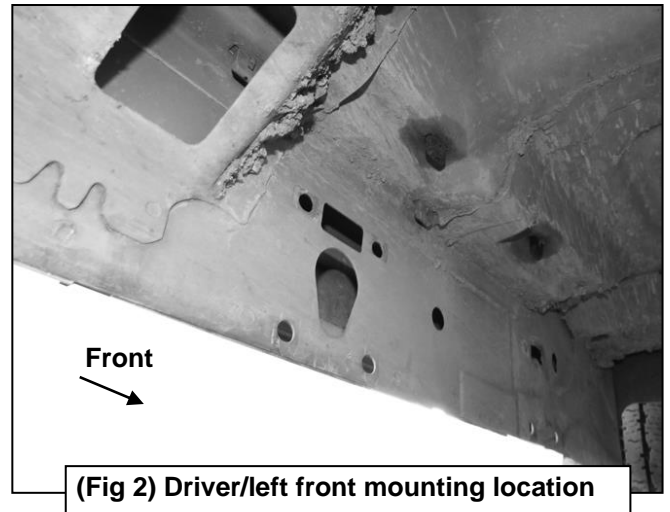
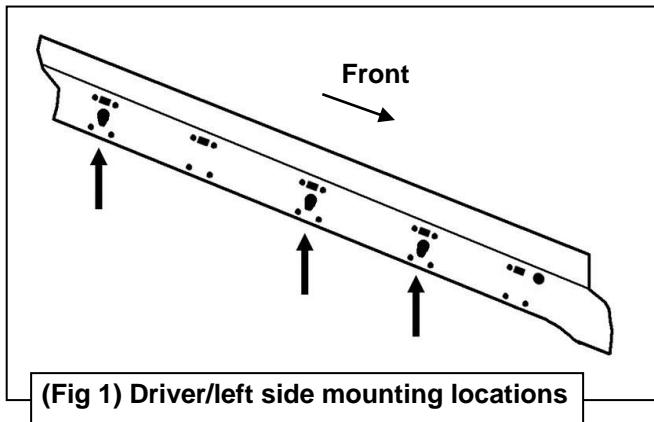

Driver Side Installation Pictured

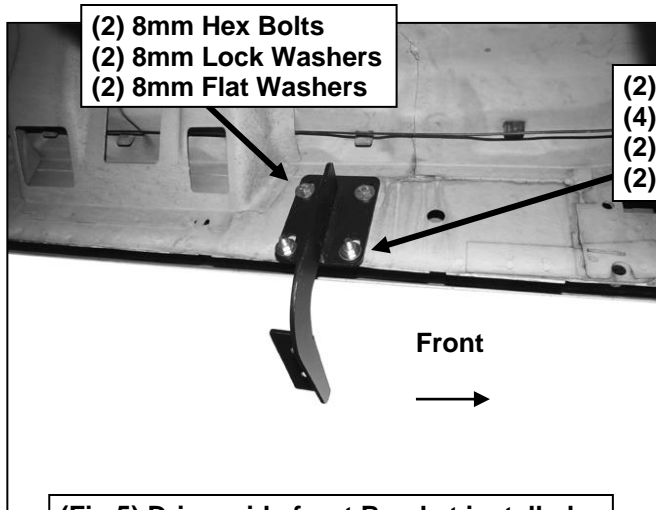

(Fig 5) Driver side front Bracket installed

(2) 8mm Clip Nuts

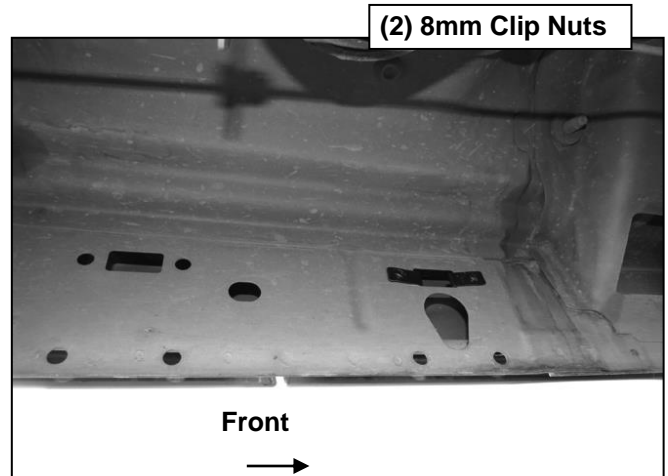

(Fig 6) Driver side center mounting location

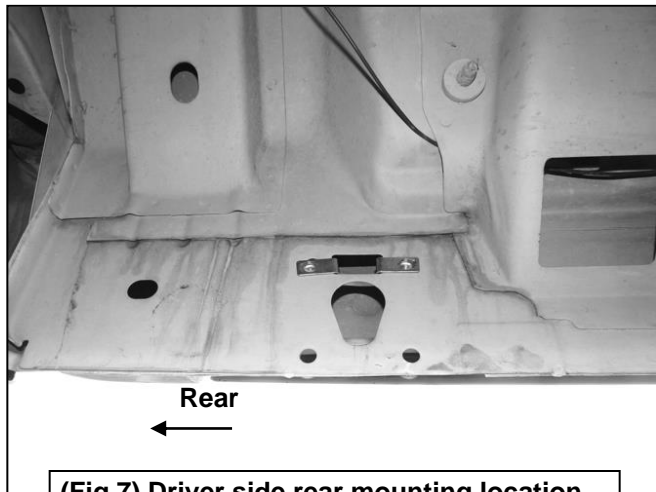

(Fig 7) Driver side rear mounting location



(Fig 8) Driver/left side rear Bracket installed

Driver Side Installation Pictured

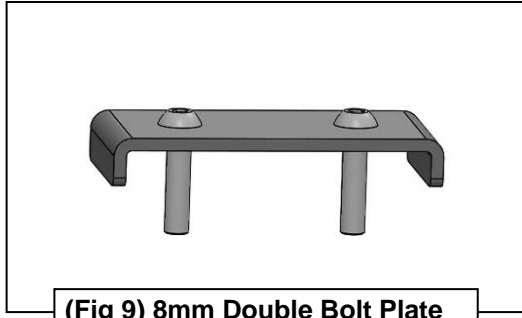

(Fig 9) 8mm Double Bolt Plate

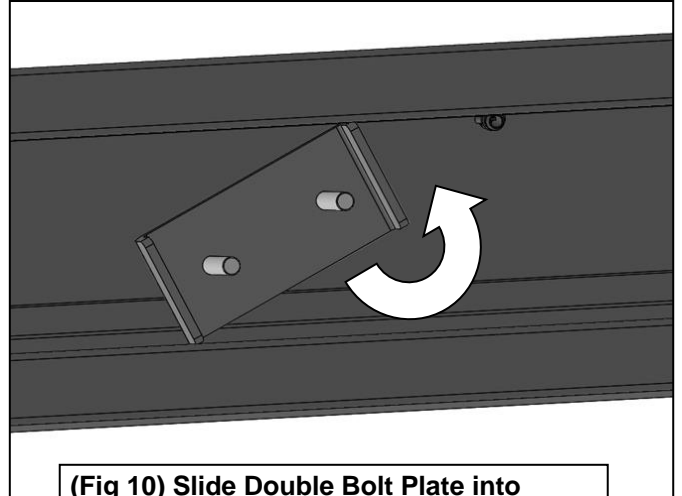

(Fig 10) Slide Double Bolt Plate into channel on the bottom of Running Board

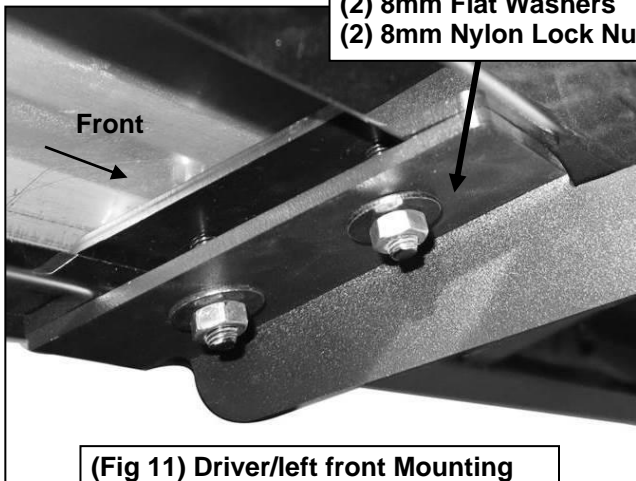

(2) 8mm Flat Washers
(2) 8mm Nylon Lock Nuts

(Fig 11) Driver/left front Mounting Bracket attached to Board pictured

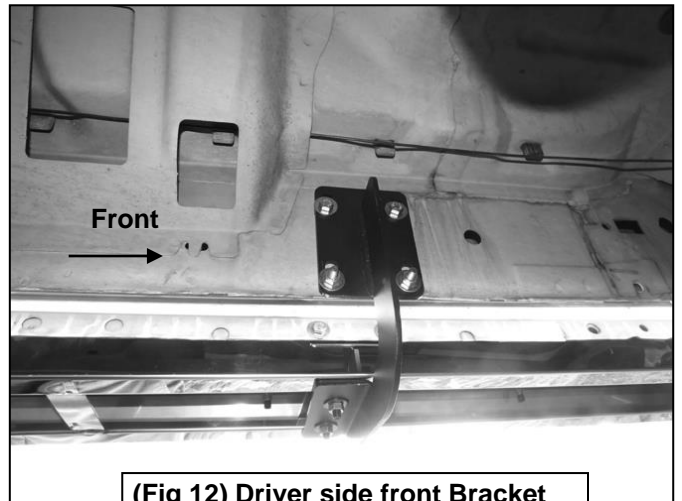

(Fig 12) Driver side front Bracket attached to Running Board

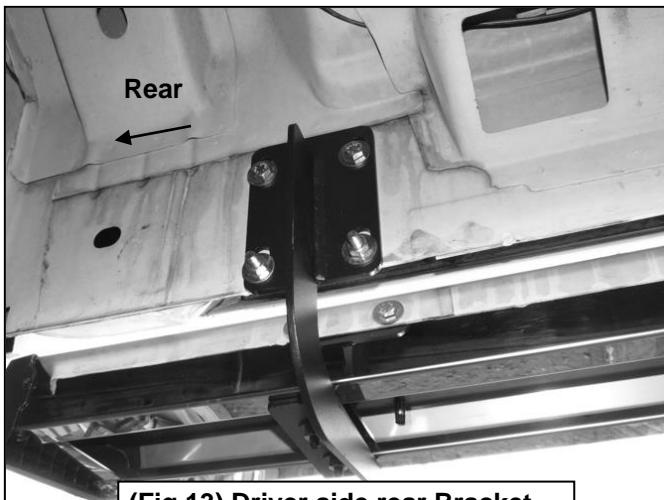

(Fig 13) Driver side rear Bracket attached to Running Board



Complete Installation