

PARTS LIST:

1	Driver/Left S6 Running Board	6	10mm Clip Nuts
1	Passenger/Right S6 Running Board	6	8mm x 35mm Double Bolt Plates
3	Driver/Left Mounting Bracket	12	8mm x 25mm Hex Bolts
3	Passenger/Right Mounting Bracket	36	8mm x 24mm OD x 2mm Flat Washers
6	10mm x 30mm Hex Bolts	12	8mm Lock Washers
6	10mm Lock Washers	12	8mm Hex Nuts
6	10mm x 30mm OD x 2.5mm Flat Washers	12	8mm Nylon Lock Nuts

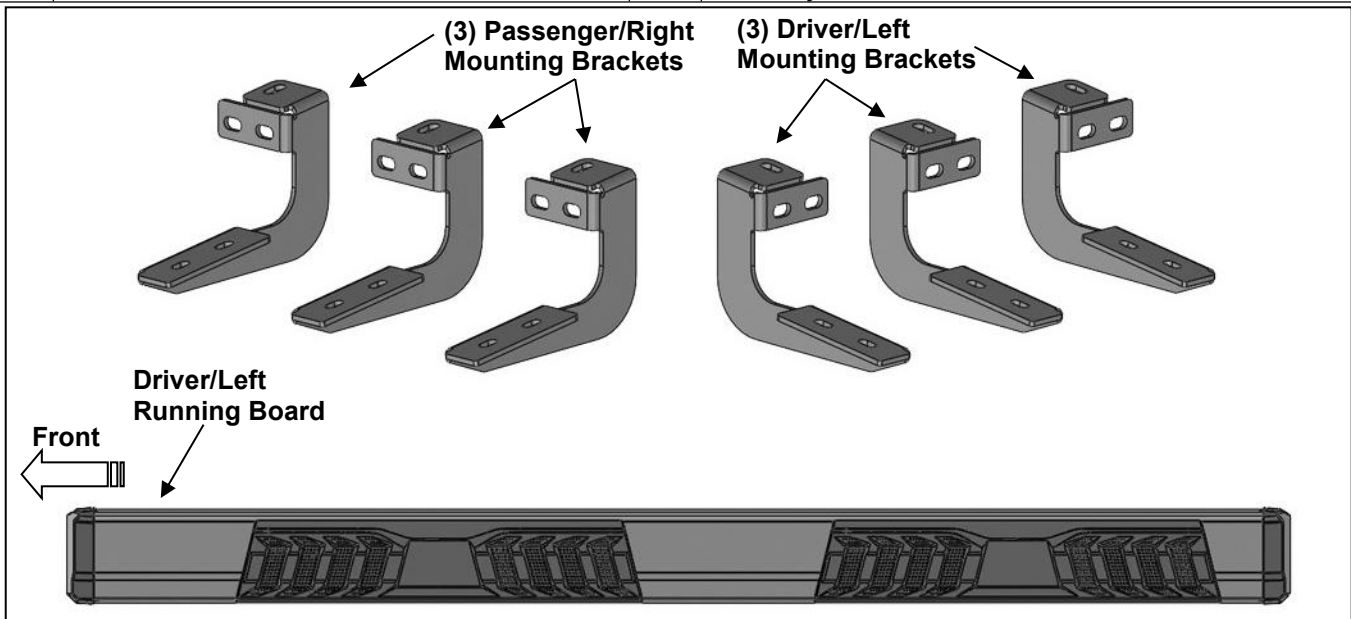

PROCEDURE:

1. REMOVE CONTENTS FROM BOX. VERIFY ALL PARTS ARE PRESENT. READ INSTRUCTIONS CAREFULLY BEFORE STARTING INSTALLATION.
2. Starting from under the front Driver/Left side, temporarily remove the plastic side panel. Move to the floor panel, locate the square holes and (2) round holes in the pinch weld, **(Figure 1)**. Select (1) 10mm Clip Nut. Attach the Clip Nut into the square hole in the floor panel, **(Figure 2)**.
3. Select (1) Driver/Left Mounting Bracket. Attach the Bracket to the 10mm Clip Nut with (1) 10mm Hex Bolt, (1) 10mm Lock Washer and (1) 10mm Flat Washer, **(Figures 3 & 5)**. Do not tighten hardware.
4. Attach the Mounting Bracket to the pinch weld with (2) 8mm Hex Bolts, (4) 8mm Flat Washers, (2) 8mm Lock Washers and (2) 8mm Hex Bolts, **(Figures 4 & 5)**. Do not tighten hardware.
5. Move along the body to the center mounting location, **(Figure 6)**. Repeat **Steps 2—4** to attach the Mounting Bracket to the center location. Do not tighten hardware.
6. Move to the rear mounting location, **(Figure 7)**. Repeat **Steps 2—4** to attach the remaining (1) Driver/Left Mounting Bracket. Do not tighten hardware.
7. Reattach the plastic side panel.
8. Unwrap the Driver/Left S6 Running Board. Select (3) 8mm Double Bolt Plates, **(Figure 8)**. Insert the Bolt Plates into the channel in the bottom of the Running Board.
9. Place the Running Board on top of the (3) Mounting Brackets. Lift the Running Board up and guide the studs down through the Brackets. **IMPORTANT:** Do not slide the Running Board on the Brackets, (front to back or rotate), or the finish on the Running Board may be damaged.
10. Attach the Running Board to the Brackets with (6) 8mm Flat Washers and (6) 8mm Nylon Lock Nuts, **(Figure 9)**. Do not tighten hardware.
11. Level and adjust the S6 Running Board and tighten all hardware.
12. Repeat **Steps 2—11** to attach the Passenger/Right S6 Running Board.
13. Do periodic inspections to the installation to make sure that all hardware is secure and tight.

To protect your investment, Do not use any type of polish or wax that may contain abrasives that could damage the finish. Mild soap may be used to clean the Running Boards.

Driver/Left side Installation Pictured



(Fig 1) Driver/Left front mounting location

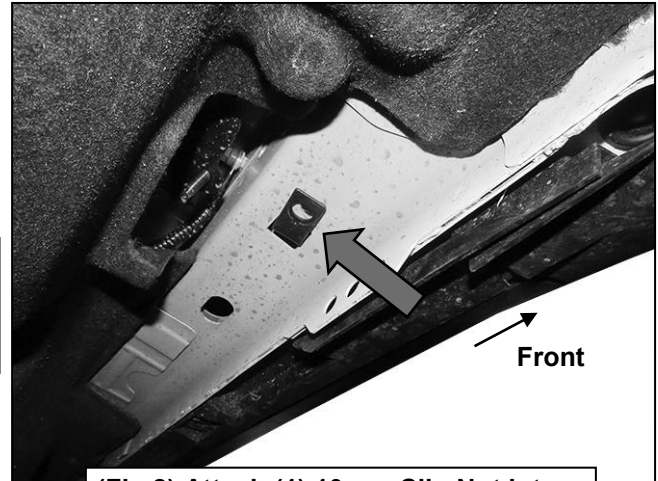

(Fig 2) Attach (1) 10mm Clip Nut into the Driver/Left front mounting location

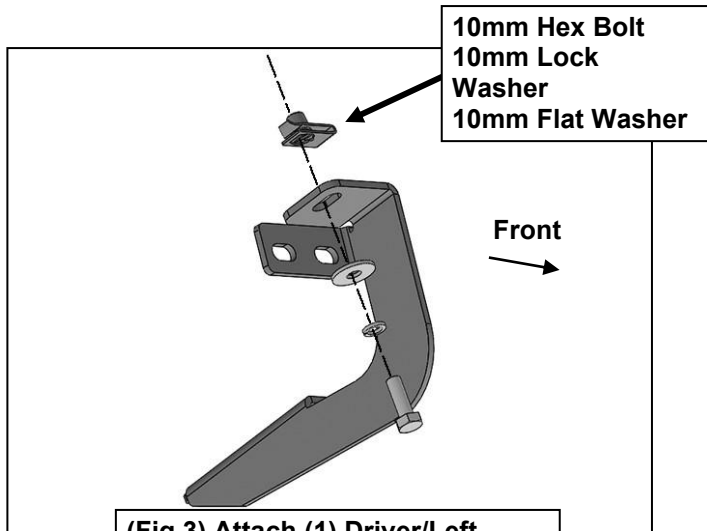

10mm Hex Bolt
10mm Lock Washer
10mm Flat Washer

(Fig 3) Attach (1) Driver/Left Mounting Bracket to the Clip Nut

(2) 8mm Hex Bolts
(4) 8mm Flat Washers
(2) 8mm Lock Washers
(2) 8mm Hex Nuts

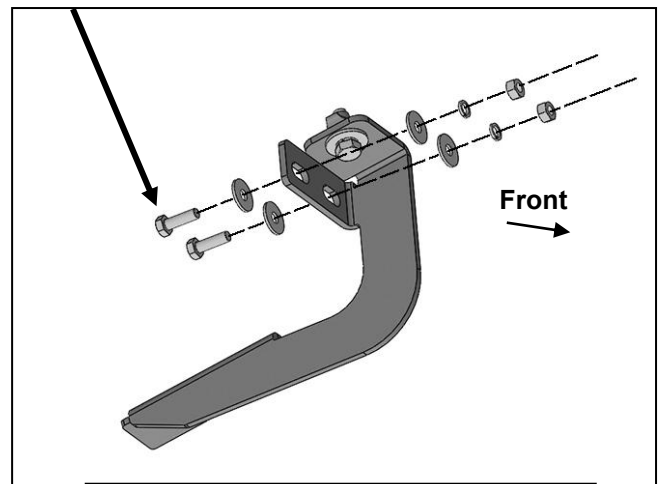

(Fig 4) Attach the Driver/Left Mounting Bracket to the pinch weld

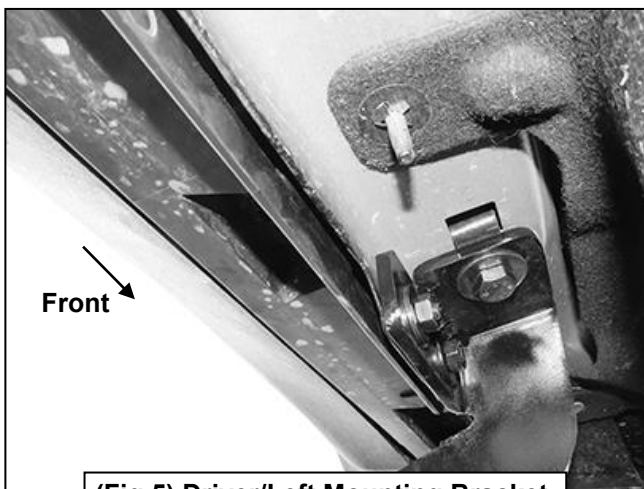

(Fig 5) Driver/Left Mounting Bracket attached to the front location

Driver/Left side Installation Pictured

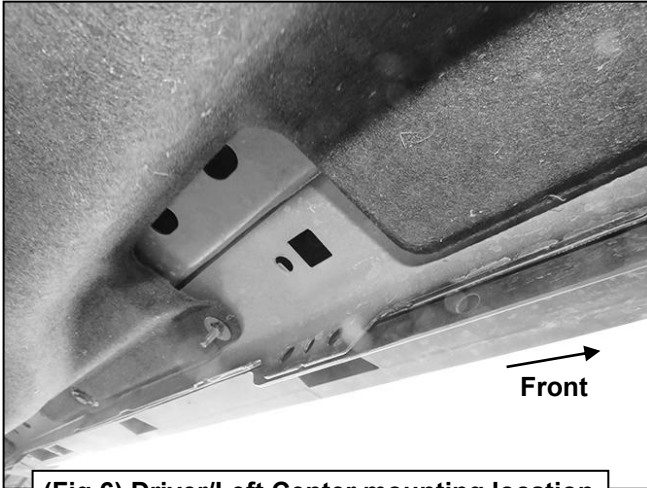

(Fig 6) Driver/Left Center mounting location



(Fig 7) Driver/Left rear mounting location

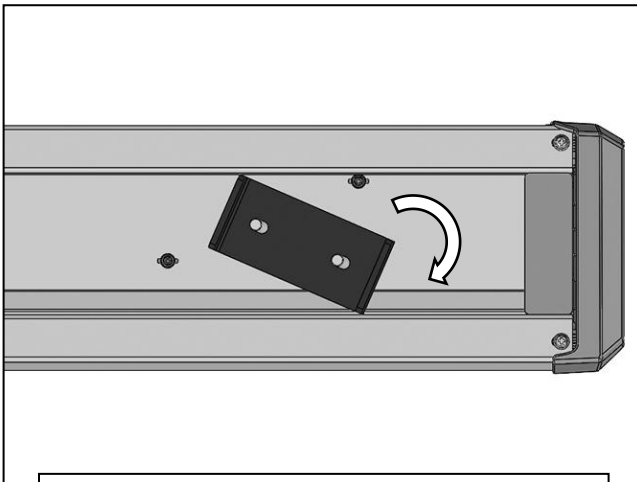

(Fig 8) Insert 8mm Double Bolt Plates into tracks on the bottom of the Running Board

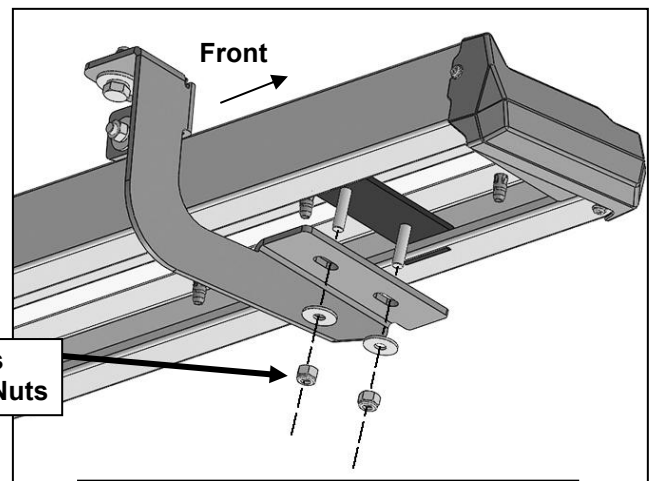

- (2) 8mm Flat Washers
- (2) 8mm Nylon Lock Nuts

(Fig 9) Attach the Driver/Left Running Board to the Bolt Plate