

PARTS LIST:

1	Driver/Left S6 Running Board	12	10mm Lock Washers
1	Passenger/Right S6 Running Board	12	10mm x 27mm OD x 3mm Flat Washers
2	Front Mounting Brackets	6	8mm x 35mm Double Bolt Plates
2	Center Mounting Brackets	12	8mm x 24mm OD x 2mm Flat Washers
2	Rear Mounting Brackets	12	8mm Nylon Lock Nuts
12	10mm x 30mm Hex Bolts		

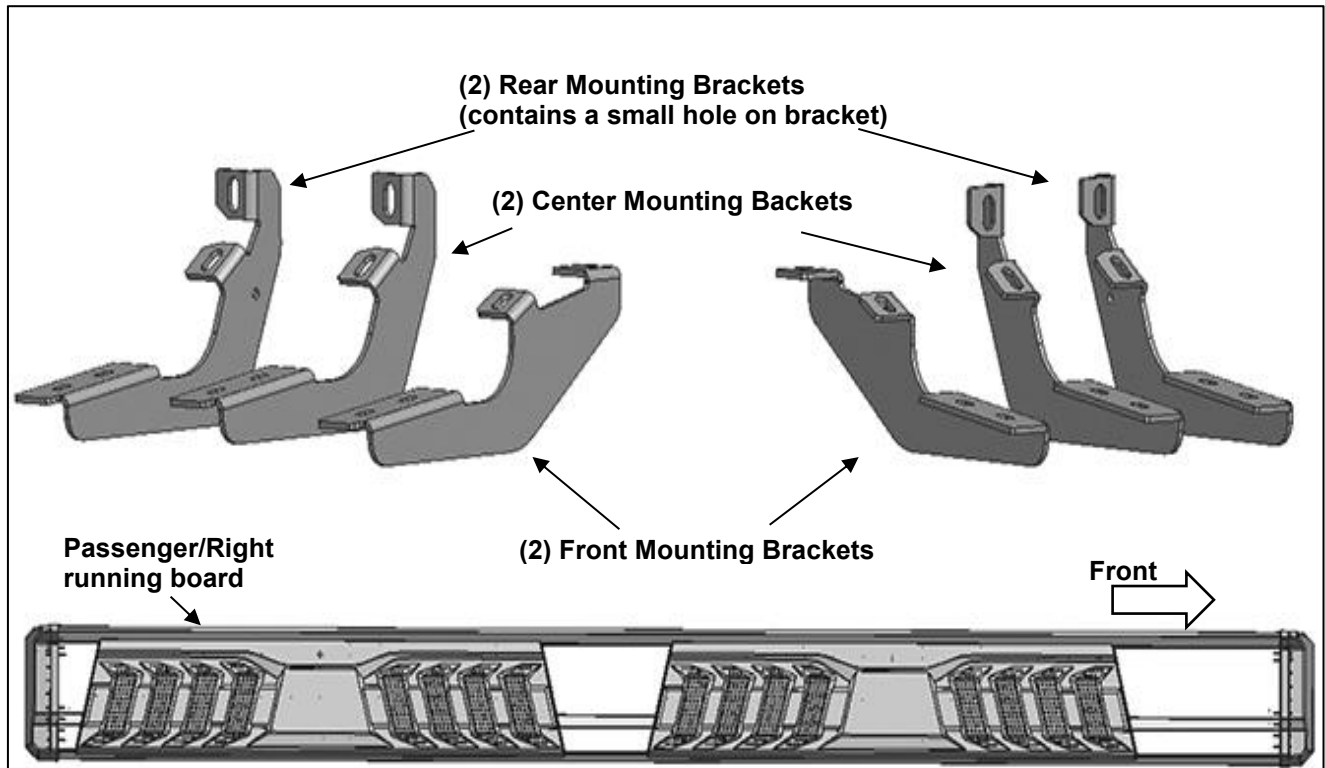

PROCEDURE:

- REMOVE CONTENTS FROM BOX. VERIFY ALL PARTS ARE PRESENT. READ INSTRUCTIONS CAREFULLY BEFORE STARTING INSTALLATION.**
- Starting from underneath the Passenger/Right body panel, locate the front mounting location and the threaded holes in the body panel, **(Figure 1)**. Remove the plastic plugs covering the holes.
- Select the Passenger/Right Front Mounting Bracket. Attach the Mounting Bracket to the front location with (2) 10mm Hex Bolts, (2) 10mm Lock Washers and (2) 10mm Flat Washers, **(Figure 2)**. Do not tighten hardware.
- Repeat **Steps 2 & 3** to attach (1) Center Mounting Bracket and (1) Rear Mounting Bracket to the center and rear locations, **(Figures 3—6)**. Do not tighten hardware. **Note:** Rear bracket has a small hole.
- Select the Passenger/Right S6 Running Board. Select (3) Double Bolt Plates. Insert the Bolt Plates into the channel in the bottom of the Running Board closest to the Brackets, **(Figure 7)**. Lift the Running Board up and guide the studs through the Brackets.
- Place the Running Board onto the Mounting Brackets. **IMPORTANT:** Do not slide the Running Board front to back or damage to the finish may result. Attach the Running Board to the Mounting Brackets with (6) 8mm Flat Washers and (6) 8mm Nylon Lock Nuts, **(Figure 8)**. Do not tighten hardware.
- Level and adjust the Running Board and tighten all hardware.
- Repeat **Steps 1—7** to attach the Driver/Left Running Board.
- Do periodic inspections to the installation to make sure that all hardware is secure and tight.

To protect your investment, Do not use any type of polish or wax that may contain abrasives that could damage the finish. Mild soap may be used to clean the Running Board.

Passenger/Right Side Installation Pictured

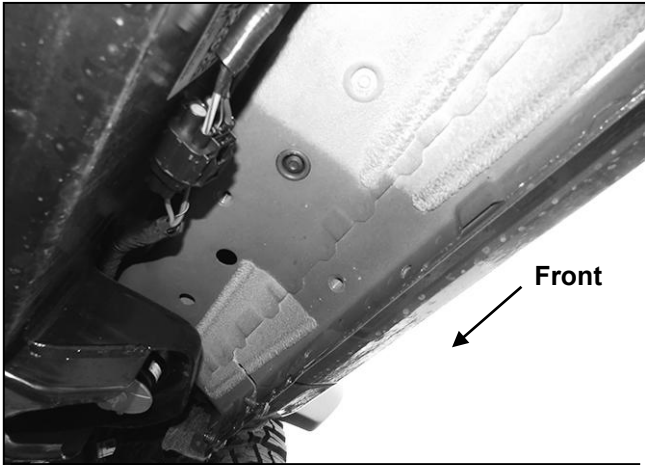

(Fig 1) Passenger/Right front mounting location

- (2) 10mm Hex Bolts
- (2) 10mm Lock Washers
- (2) 10mm Flat Washers

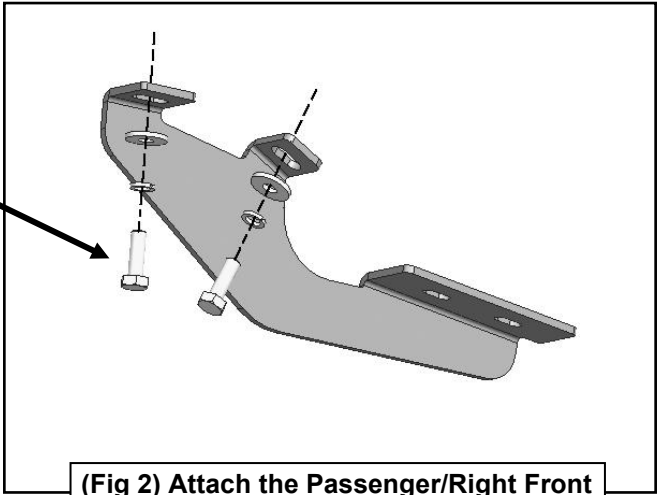

(Fig 2) Attach the Passenger/Right Front Mounting Bracket to the front location

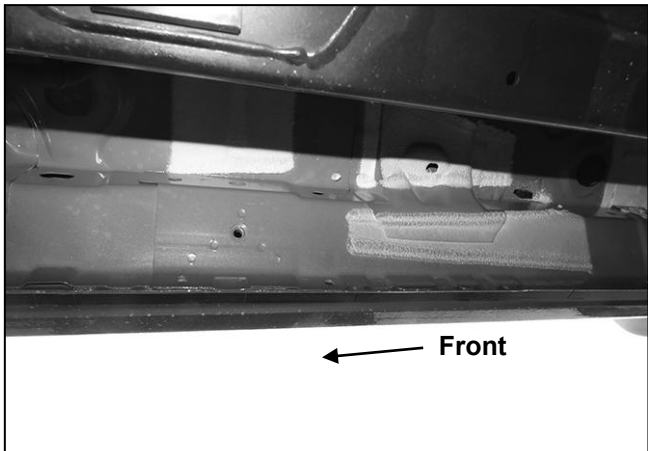

(Fig 3) Passenger/Right center mounting location

Passenger/Right Side Installation Pictured

- (2) 10mm Hex Bolts
- (2) 10mm Lock Washers
- (2) 10mm Flat Washers

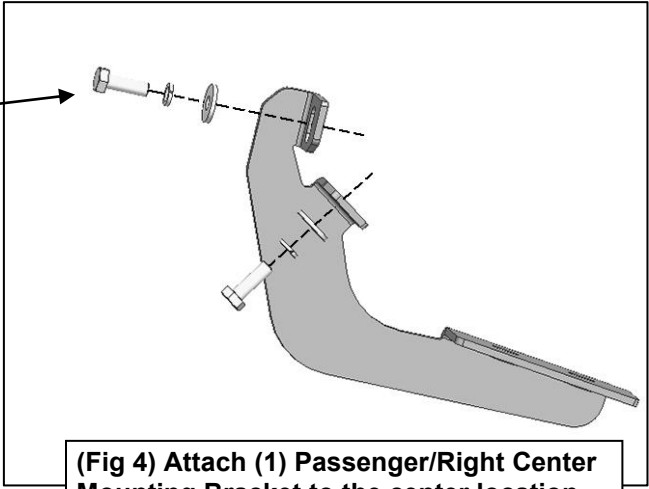

(Fig 4) Attach (1) Passenger/Right Center Mounting Bracket to the center location

- (2) 10mm Hex Bolts
- (2) 10mm Lock Washers
- (2) 10mm Flat Washers

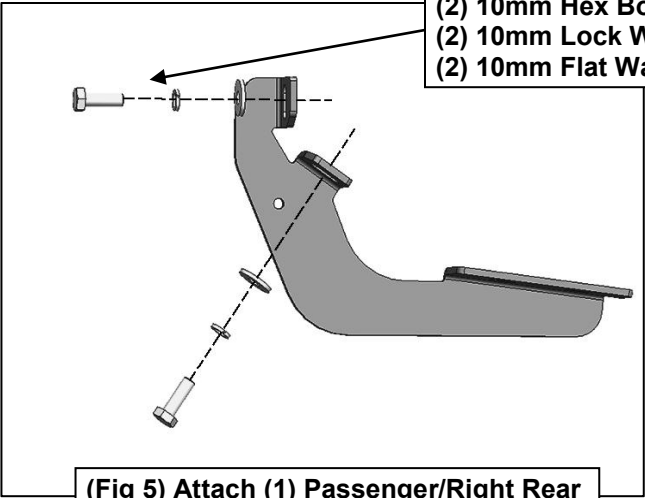

(Fig 5) Attach (1) Passenger/Right Rear Mounting Bracket to the rear location

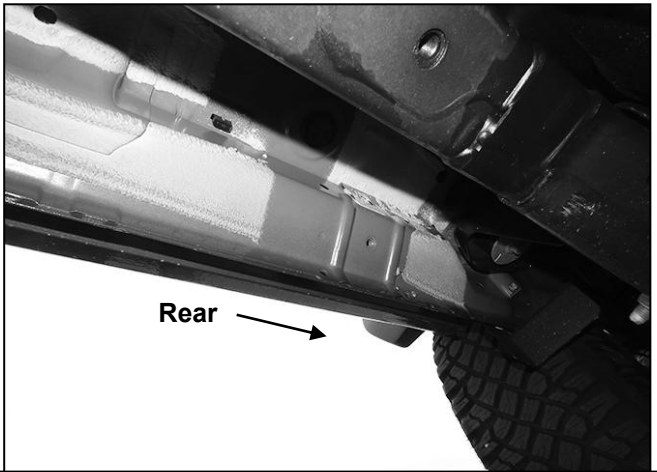

(Fig 6) Passenger/Right Rear mounting location

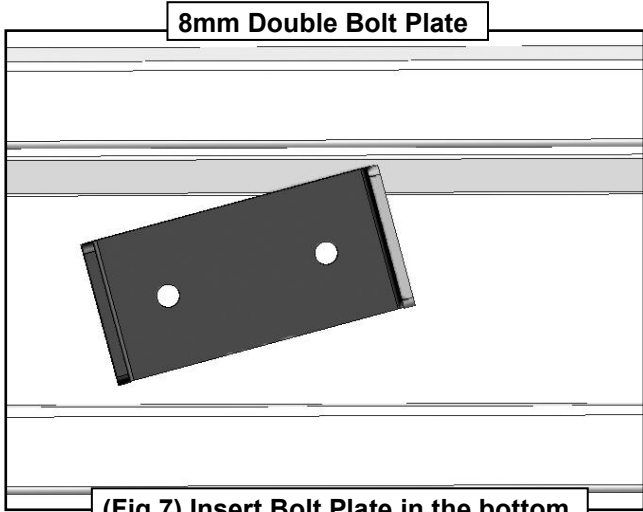

(Fig 7) Insert Bolt Plate in the bottom of the channel on the Running Board

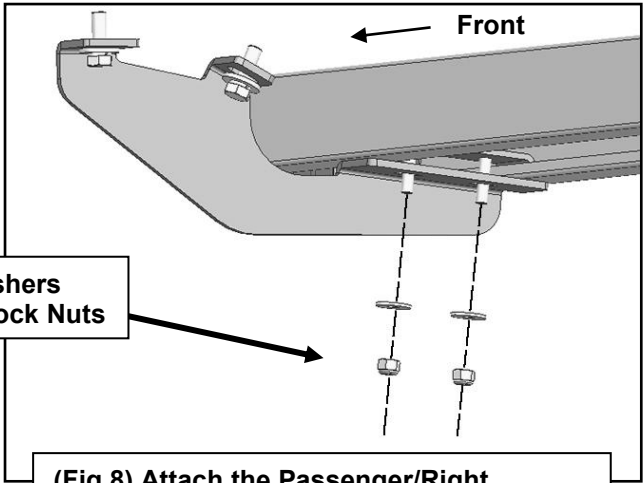

(Fig 8) Attach the Passenger/Right Running Board to the Mounting Brackets