

PARTS LIST:

1	Driver/Left S6 Running Board	8	10mm Spiral Bolts
1	Passenger/Right S6 Running Board	2	10mm x 60mm Hex Bolts
1	Driver/Left Front Mounting Bracket	14	10mm x 27mm OD x 2mm Flat Washers
1	Passenger/Right Front Mounting Bracket	14	10mm Lock Washers
1	Driver/Left Center Mounting Bracket	14	10mm Hex Nuts
1	Passenger/Right Center Mounting Bracket	4	10mm Plastic Retainers
1	Driver/Left Rear Mounting Bracket	6	8mm x 35mm Double Bolt Plates
1	Passenger/Right Rear Mounting Bracket	4	8mm x 25mm Hex Bolts
1	Driver/Left Center Support Bracket	20	8mm x 24mm OD x 2mm Flat Washers
1	Passenger/Right Center Support Bracket	4	8mm Lock Washers
2	Compression Plates	4	8mm Hex Nuts
2	10mm x 40mm Long Bolt Plates	12	8mm Nylon Lock Nuts
2	10mm x 40mm Short Bolts Plates		

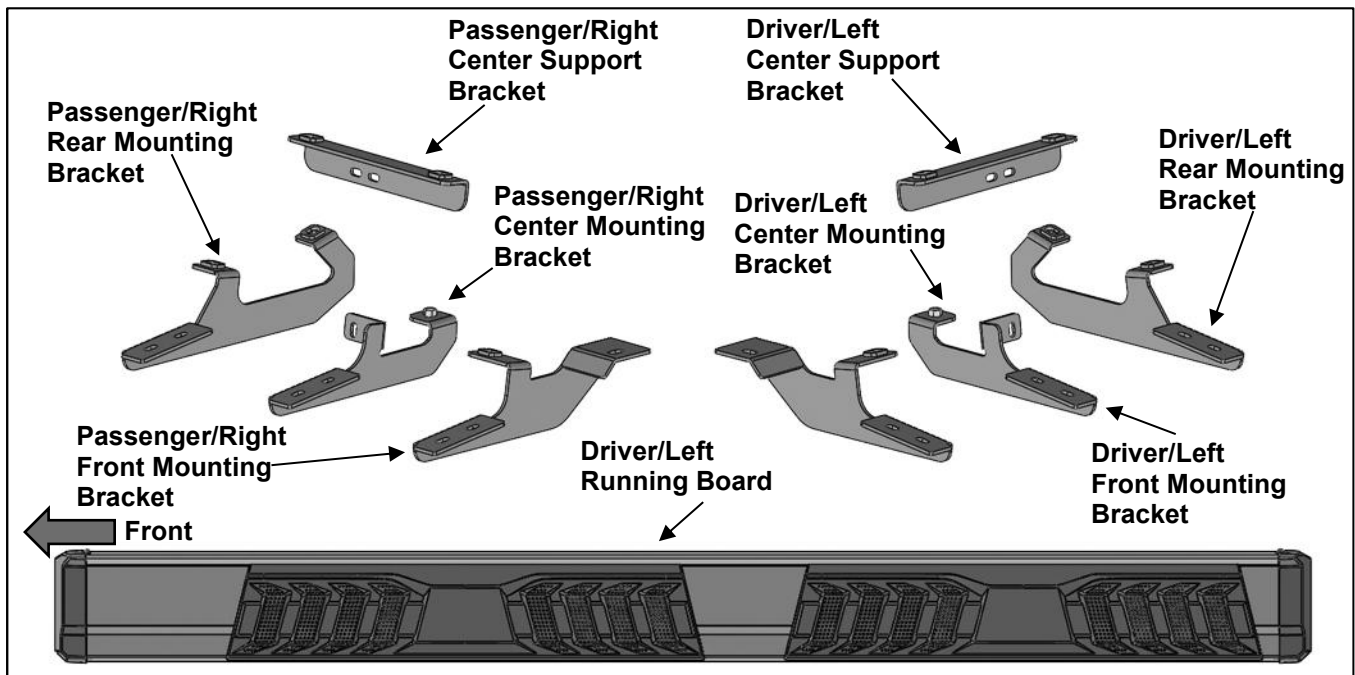

PROCEDURE:

1. REMOVE CONTENTS FROM BOX. VERIFY ALL PARTS ARE PRESENT. READ INSTRUCTIONS CAREFULLY BEFORE STARTING INSTALLATION.
2. Starting under the Driver/Left side of the vehicle, remove the large plastic cover on the bottom of the floor panel, (Figure 1). Determine which plastic clips need to be removed. Carefully remove only the plastic clips for installation, (Figures 2 & 3).
3. Locate the front mounting location, (Figure 4). Select (1) 10mm Spiral Bolt. Insert the Spiral Bolt into the side panel, (Figures 8A & 8B). Select (1) 10mm Short Bolt Plate. Insert the Bolt Plate into the floor panel, (Figure 9). Thread (1) 10mm Plastic Retainer onto the Bolt Plate to hold it in place.
 - a. With the Spiral Bolt threads pointing away from the vehicle, insert the tail all the way up into the slot. Keep threads pointed outwards, (Figure 5).
 - b. Slide in the bend in the tail up into the slot, keeping the threads pointed outwards, (Figure 6).
 - c. Rotate Spiral Bolt downwards so that the threads are pointed towards the ground, (Figure 7).
 - d. Follow link for 10mm Spiral Bolt installation. <https://youtu.be/BqQis3QjZnc>



4. Select the Driver/Left Mounting Bracket. Attach the Mounting Bracket to the Bolt Plate with (1) 10mm Flat Washer, (1) 10mm Lock Washer and (1) 10mm Hex Nut, (Figure 10). Do not tighten hardware.

Attach the Bracket to the Spiral Bolt with (1) 10mm Flat Washer, (1) 10mm Lock Washer and (1) 10mm Hex Nut, (**Figure 11**). Do not tighten hardware.

5. Move to the center location, (**Figure 12**). Insert (2) 10mm Spiral Bolts into the side panel, (**Figure 13**). Select the Driver/Left Center Support Bracket. Attach the Bracket to the (2) Spiral Bolts with (2) 10mm Flat Washers, (2) 10mm Lock Washers and (2) 10mm Hex Nuts, (**Figure 14**). Do not tighten hardware.
6. Select the Center Mounting Bracket. Attach the Mounting Bracket to the Support Bracket with (2) 8mm Hex Bolts, (4) 8mm Flat Washers, (2) 8mm Lock Washers and (2) 8mm Hex Nuts, (**Figure 15**). Do not tighten hardware.
7. Select (1) Compression Plate.
 - a. Thread (1) 10mm Hex Nut to (1) 10mm x 60mm Hex Bolt.
 - b. Slide (1) 10mm Lock Washer and (1) 10mm Flat washer onto the 10mm Hex Bolt.
 - c. Thread the 10mm Hex Bolt assembly into the welded nut on the back of the Mounting Bracket. Place the Compression Plate onto the end of the 10mm Hex Bolt, (**Figures 16A & 16B**).
 - d. Tighten Hex Bolt to place the Compression Plate onto the floor panel. Do not tighten Hex Bolt all the way. **NOTE:** Use the 10mm Hex Nut to adjust the level of the Mounting Bracket.
 - e. Follow link for Compression Plate installation. <https://youtu.be/R51s7VvK1Sy4>



8. Move to the rear mounting location. Repeat **Steps 3 & 4** to attach the Driver/Left Rear Mounting Bracket, (**Figures 17—19**). Do not tighten hardware.
9. Unwrap the Driver/Left S6 Running Board. Select (3) 8mm Double Bolt Plates, (**Figure 20**). Insert the Bolt Plates into the channel in the bottom of the Running Board.
10. Place the Running Board on top of the (3) Mounting Brackets. Lift the Running Board up and guide the studs down through the Brackets. **IMPORTANT:** Do not slide the Running Board on the Brackets, (front to back or rotate), or the finish on the Running Board may be damaged.
11. Attach the Running Board to the Brackets with (6) 8mm Flat Washers and (6) 8mm Nylon Lock Nuts, (**Figure 21**). Do not tighten hardware.
12. Level and adjust the Running Board and tighten all hardware.
13. Repeat **Steps 2—12** to attach the Passenger/Right S6 Running Board
14. Do periodic inspections to the installation to make sure that all hardware is secure and tight.

To protect your investment, Do not use any type of polish or wax that may contain abrasives that could damage the finish. Mild soap may be used to clean the Running Boards.

Remove plastic trim clips

Remove factory pins and hardware

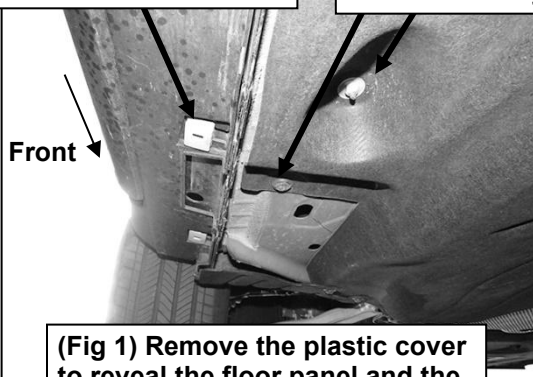

(Fig 1) Remove the plastic cover to reveal the floor panel and the plastic clips in the outer trim

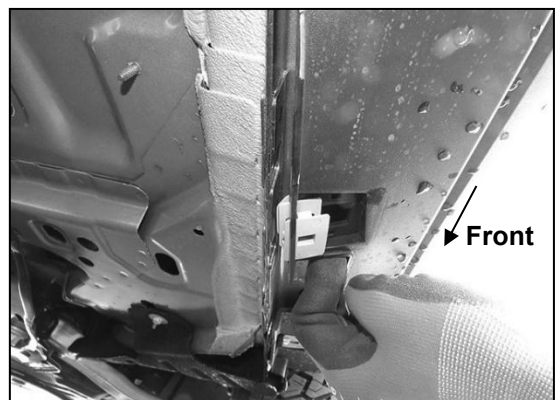

(Fig 2) Gently pull the trim slightly to loosen the clips (Passenger side shown)

Driver/Left Side Installation Pictured



(Fig 3) Plastic clip removed from the front location trim (Passenger side shown)

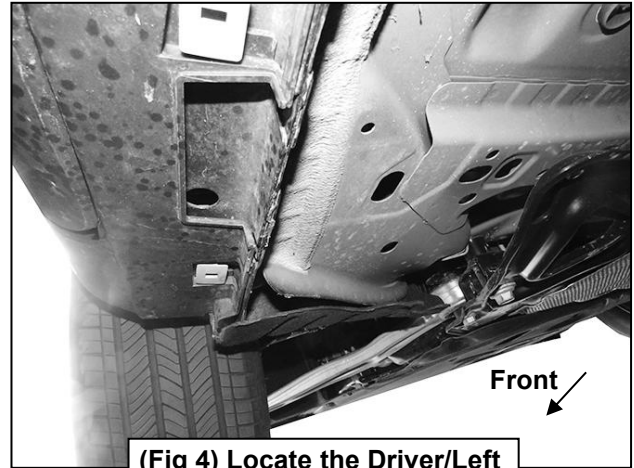

(Fig 4) Locate the Driver/Left front mounting location



(Fig 5) Insert the tail on the Spiral Bolt into the slot, keeping the threads pointed outwards



(Fig 6) Insert the bend on the tail into the slot, keeping the threads pointed outwards

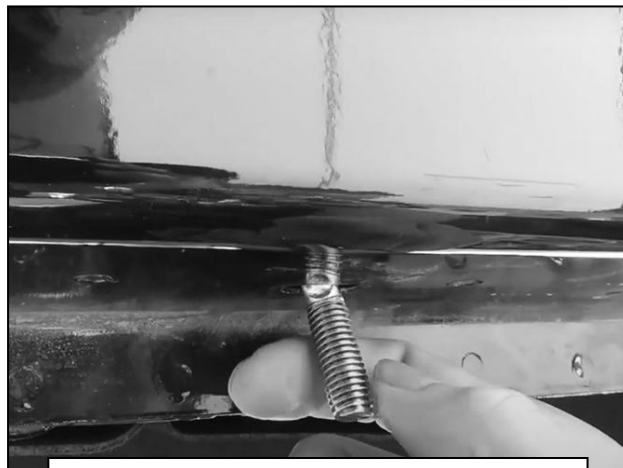

(Fig 7) Rotate the Spiral Bolt downwards

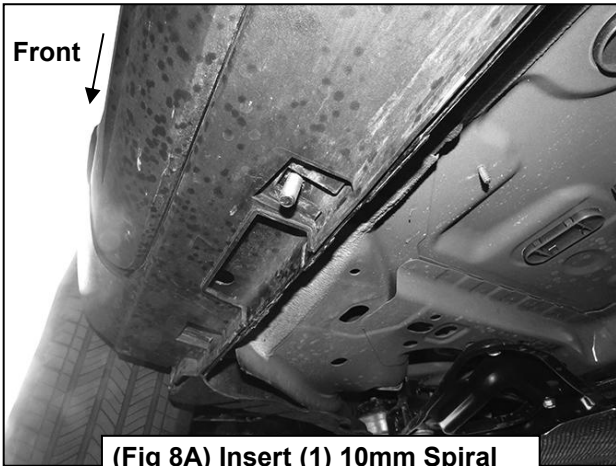

(Fig 8A) Insert (1) 10mm Spiral Bolt into the side panel

(Fig 8B) Follow link for 10mm Spiral Bolt installation.
<https://youtu.be/BqQis3QjZNc>

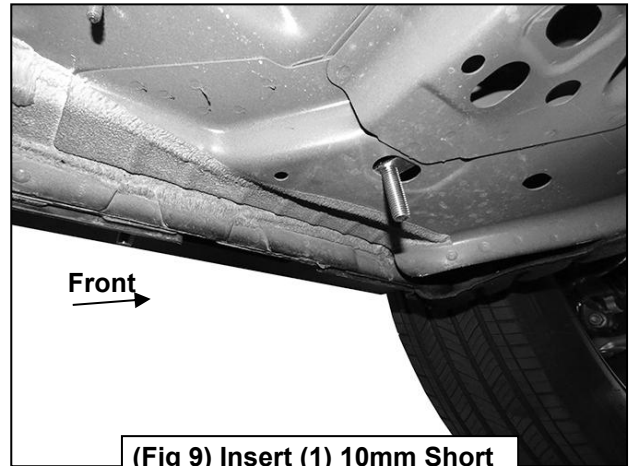

(Fig 9) Insert (1) 10mm Short Bolt Plate into the floor panel

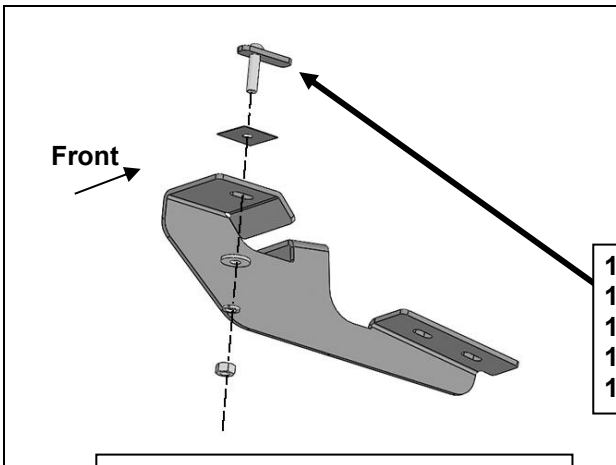

(Fig 10) Attach the Driver/Left Front Mounting Bracket to the Bolt Plate

10mm Short Bolt Plate
10mm Plastic Retainer
10mm Flat Washer
10mm Lock Washer
10mm Hex Nut

10mm Spiral Bolt
10mm Flat Washer
10mm Lock Washer
10mm Hex Nut

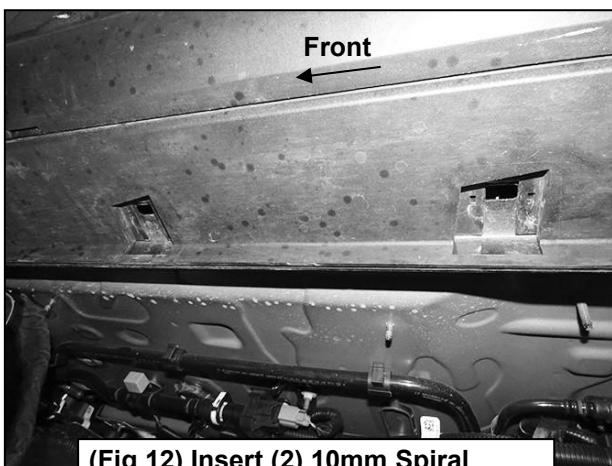

(Fig 12) Insert (2) 10mm Spiral Bolts into the outer center location

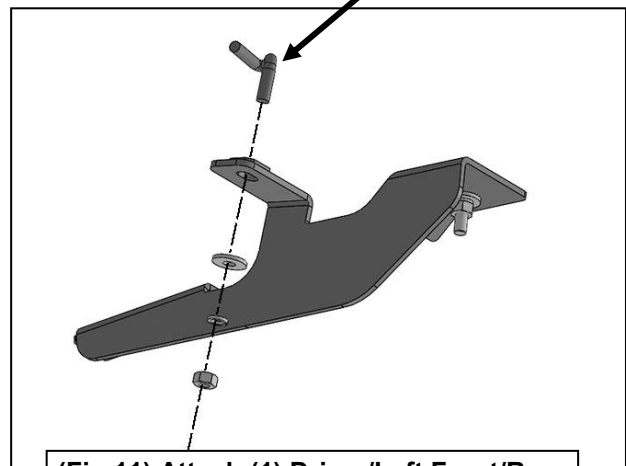

(Fig 11) Attach (1) Driver/Left Front/Rear Support Bracket to the Spiral Bolt

Driver/Left Side Installation Pictured

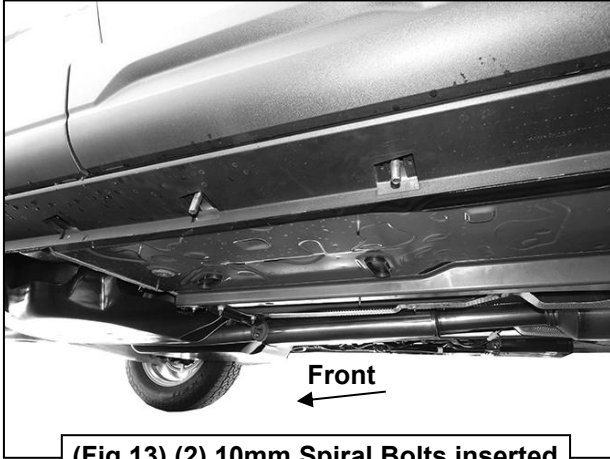

(Fig 13) (2) 10mm Spiral Bolts inserted into the outer center location

- (2) 10mm Spiral Bolts
- (2) 10mm Flat Washers
- (2) 10mm Lock Washers
- (2) 10mm Hex Nuts

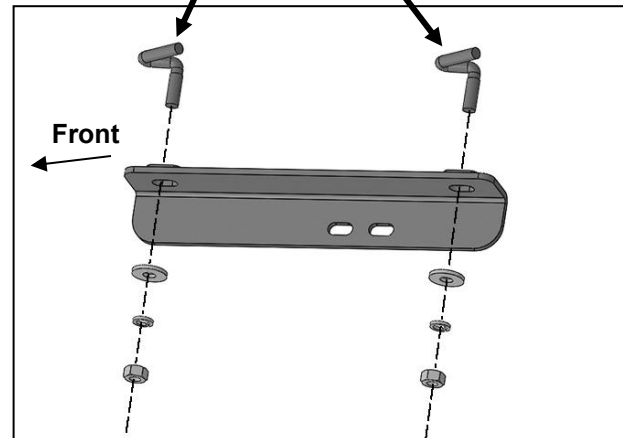

(Fig 14) Attach the Driver/Left Center Support Bracket to the (2) 10mm Spiral Bolts

- (2) 8mm Hex Bolts
- (4) 8mm Flat Washers
- (2) 8mm Lock Washers
- (2) 8mm Hex Nuts

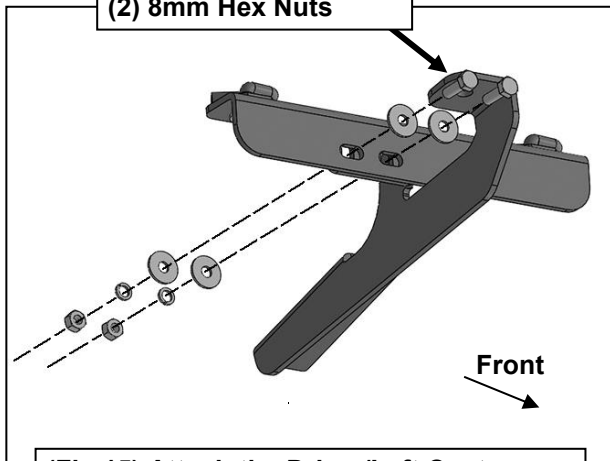

(Fig 15) Attach the Driver/Left Center Mounting Bracket to the Support Bracket

- 10mm x 60mm Hex Bolt
- 10mm Hex Nut
- 10mm Lock Washer
- 10mm Flat Washer
- Compression Plate

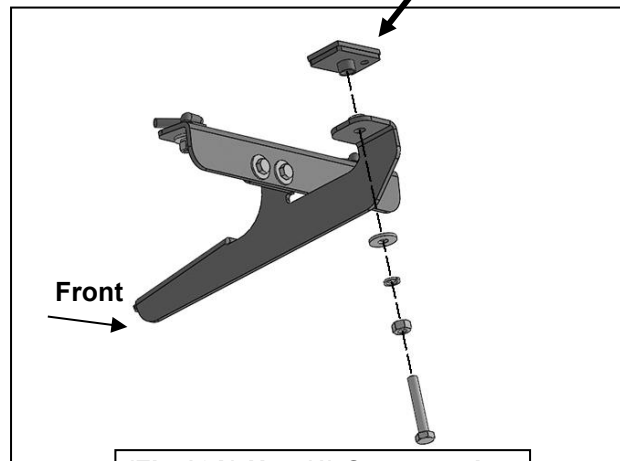

(Fig 16A) Use (1) Compression Plate to level the Bracket (Note use the Hex Nuts as adjusters)

(Fig 16B) Follow link for Compression Plate installation.
<https://youtu.be/R51s7Vk1Sy4>



Driver/Left Side Installation Pictured



(Fig 17) Example of the rear location (Passenger side shown)

- 10mm Spiral Bolt
- 10mm Flat Washer
- 10mm Lock Washer
- 10mm Hex Nut

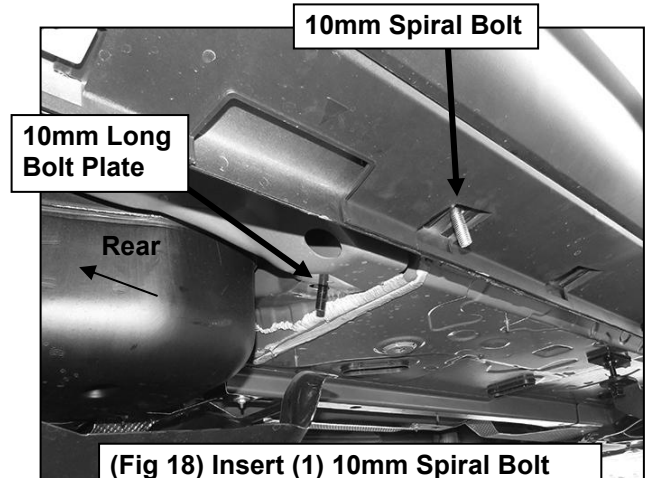

(Fig 18) Insert (1) 10mm Spiral Bolt into the side panel and (1) 10mm Long Bolt Plate into the floor panel

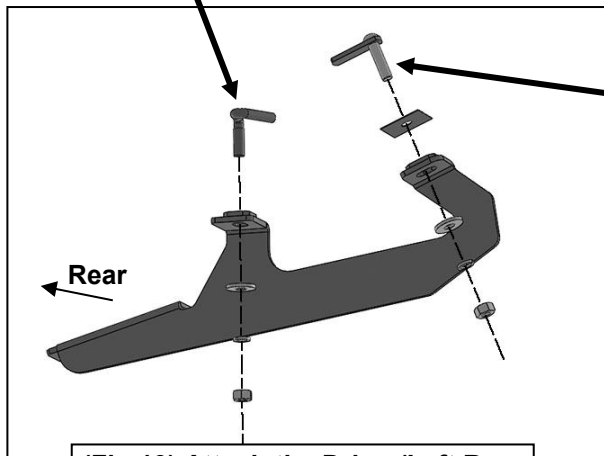

- 10mm Short Bolt Plate
- 10mm Plastic Retainer
- 10mm Flat Washer
- 10mm Lock Washer
- 10mm Hex Nut

(Fig 19) Attach the Driver/Left Rear Mounting Bracket to the Bolt Plate

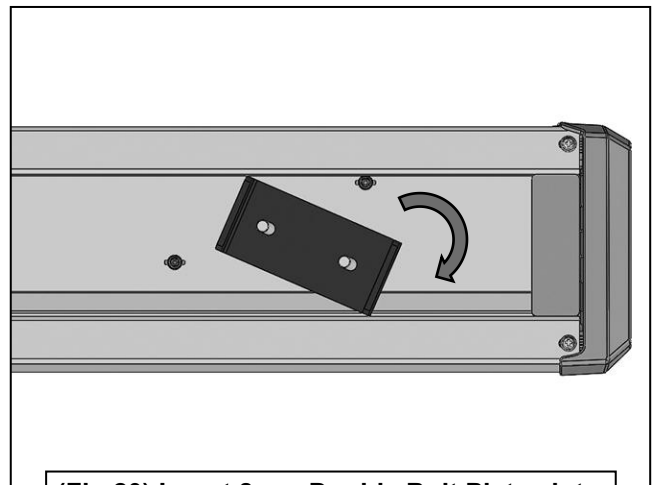

(Fig 20) Insert 8mm Double Bolt Plates into tracks on the bottom of the Running Board

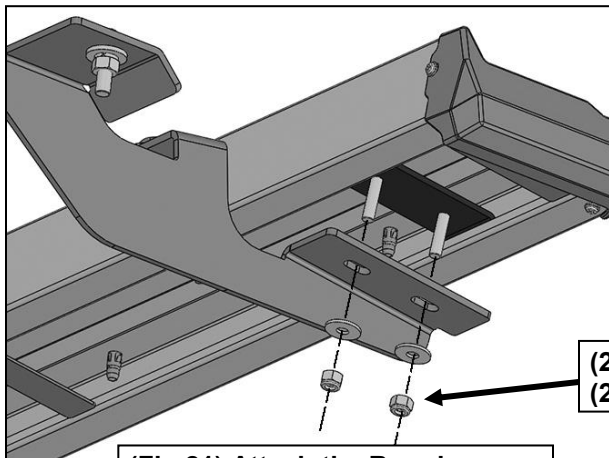

- (2) 8mm Flat Washers
- (2) 8mm Nylon Lock Nuts

(Fig 21) Attach the Running Board to the Mounting Brackets