

PARTS LIST:

1	Driver/Left S6 Running Board	6	8mm Double Bolt Plates
1	Passenger/Right S6 Running Board	24	8mm x 24mm OD x 2mm Flat Washers
2	Front Mounting Brackets	24	8mm Nylon Lock Nuts
4	Rear Mounting Brackets	12	8mm Plastic Retainers

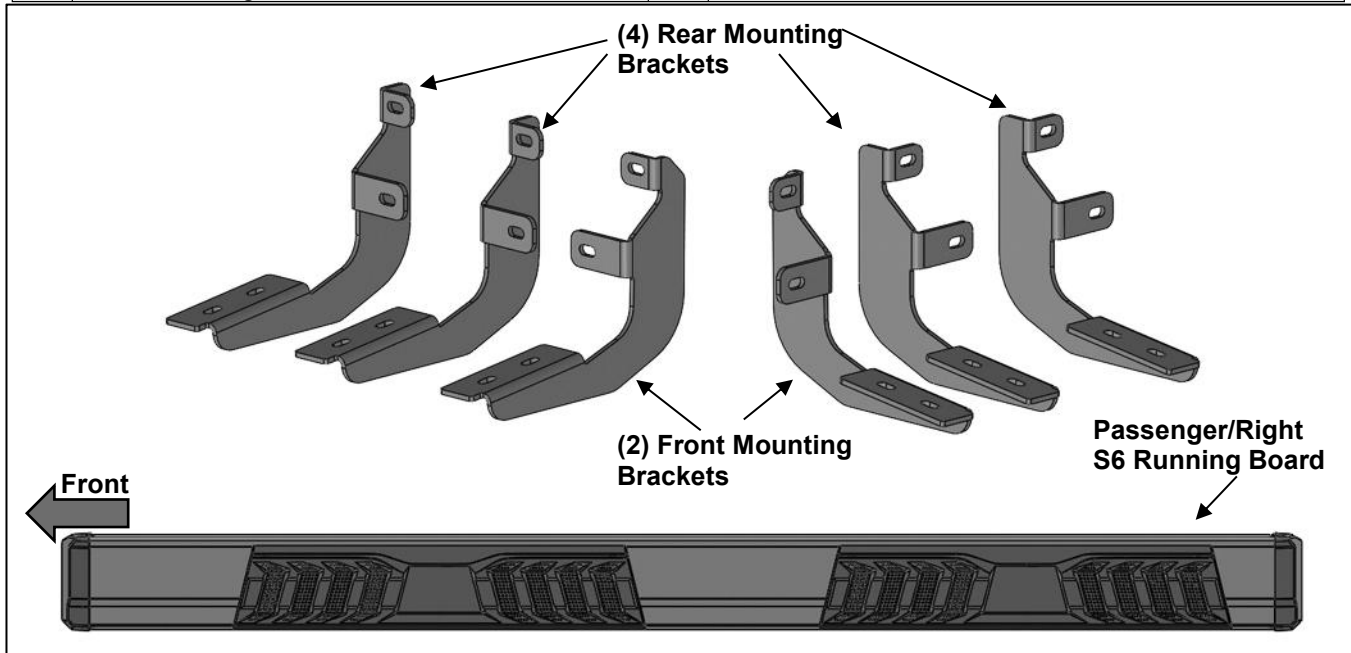

PROCEDURE:

- 1. REMOVE CONTENTS FROM BOX. VERIFY ALL PARTS ARE PRESENT. READ INSTRUCTIONS CAREFULLY BEFORE STARTING INSTALLATION.**
- Starting from underneath the Driver/Left side of the vehicle, from underneath, locate the factory side products mounting locations, **(Figure 1)**. Remove the side products and set aside in a safe location, **(Figure 2)**.
- Select (1) Front Mounting Bracket. Attach the Mounting Bracket to the studs in the front location with (2) 8mm Plastic Retainers, (2) 8mm Flat Washers and (2) 8mm Nylon Lock Nuts, **(Figure 3)**. Do not tighten hardware. **IMPORTANT:** The Plastic Washers are designed to prevent corrosion between the aluminum body panel and the steel mounting brackets. **Do not install the Brackets without the Plastic Washers.**
- Repeat **Step 3** to attach (2) Rear Mounting Brackets to the center and rear locations, **(Figures 4—6)**. Do not tighten hardware.
- Unwrap the Driver/Left S6 Running Board. Select (3) 8mm Double Bolt Plates, **(Figure 7)**. Insert the Bolt Plates into the channel in the bottom of the Running Board.
- Place the Running Board on top of the (3) Mounting Brackets. Lift the Running Board up and guide the studs down through the Brackets. **IMPORTANT:** Do not slide the Running Board on the Brackets, (front to back or rotate), or the finish on the Running Board may be damaged.
- Attach the Running Board to the Brackets with (6) 8mm Flat Washers and (6) 8mm Nylon Lock Nuts, **(Figure 8)**. Do not tighten hardware.
- Level and adjust the S6 Running Board and tighten all hardware.
- Repeat **Steps 1—8** to attach the Passenger/Right S6 Running Board.
- Do periodic inspections to the installation to make sure that all hardware is secure and tight.

To protect your investment, Do not use any type of polish or wax that may contain abrasives that could damage the finish. Mild soap may be used to clean the Running Boards.

Driver/Left side Installation Pictured

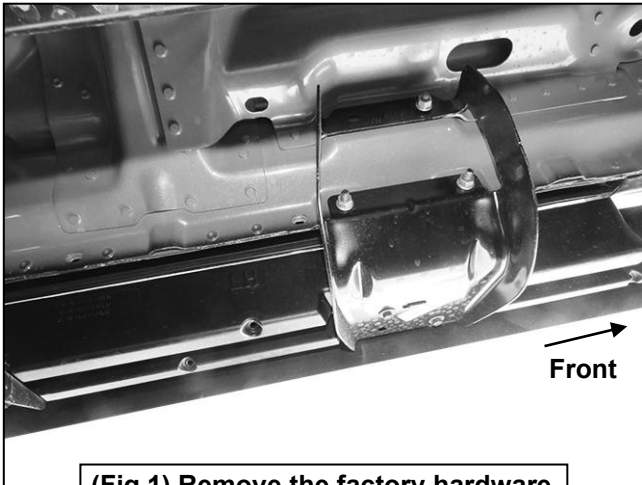

(Fig 1) Remove the factory hardware to remove the factory side products

- (2) 8mm Plastic Retainers
- (2) 8mm Flat Washers
- (2) 8mm Nylon Lock Nuts

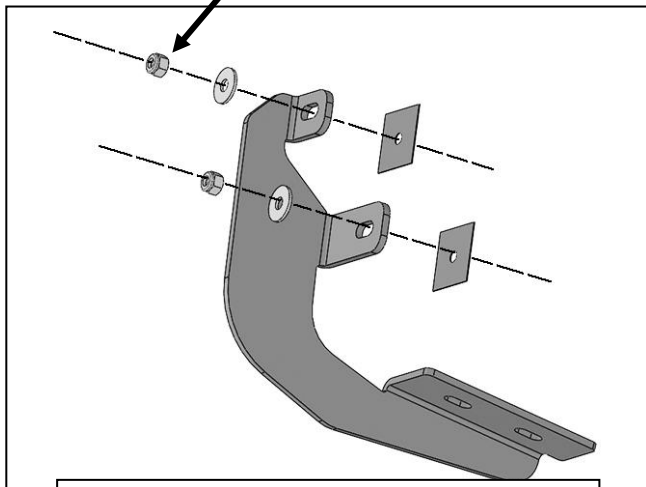

(Fig 3) Attach (1) Front Mounting Bracket to the Driver/Left front location



(Fig 2) Driver/Left front mounting location

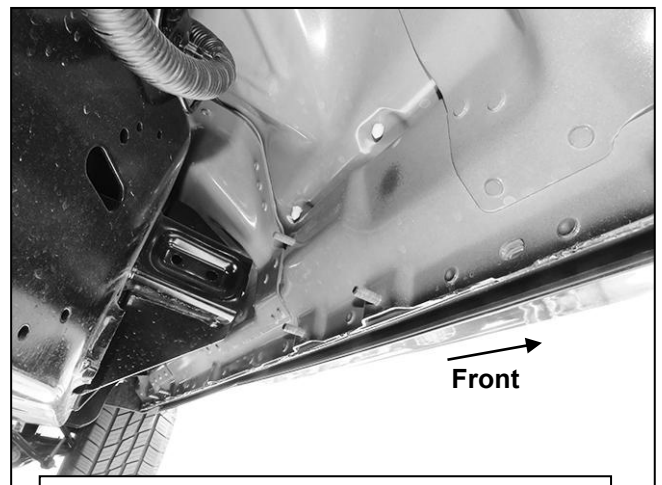

(Fig 4) Driver/Left center mounting location

Passenger/Right side Installation Pictured

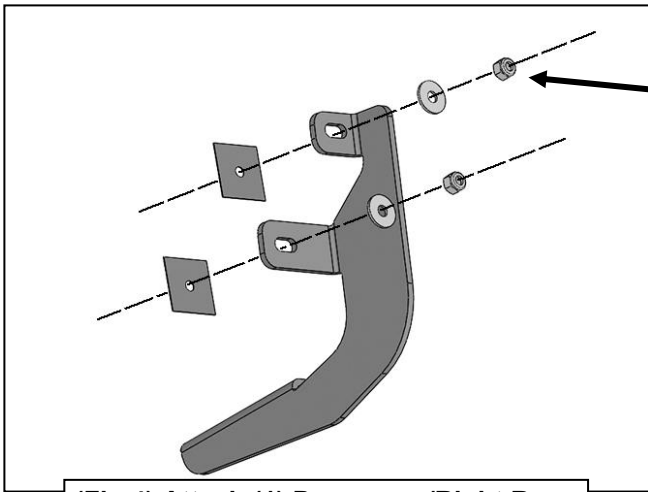

- (2) 8mm Plastic Retainers
- (2) 8mm Flat Washers
- (2) 8mm Nylon Lock Nuts

(Fig 4) Attach (1) Passenger/Right Rear Mounting Bracket to the center location

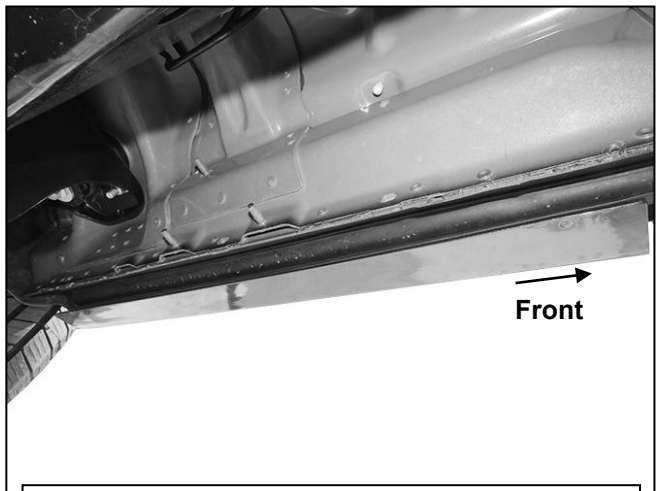

(Fig 5) Passenger/Right rear mounting location

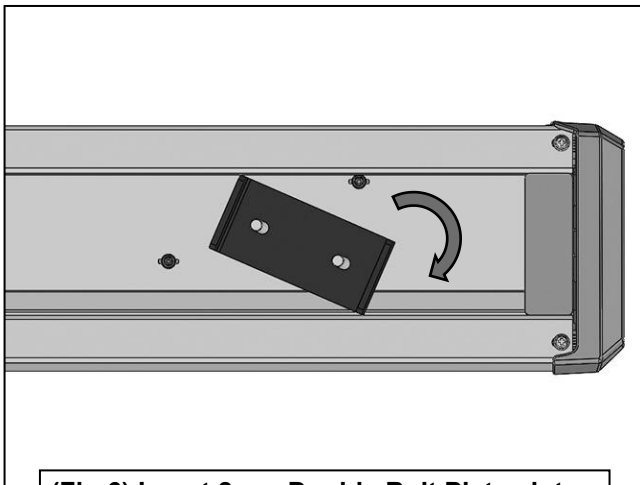

(Fig 6) Insert 8mm Double Bolt Plates into tracks on the bottom of the Running Board

- (2) 8mm Flat Washers
- (2) 8mm Nylon Lock Nuts

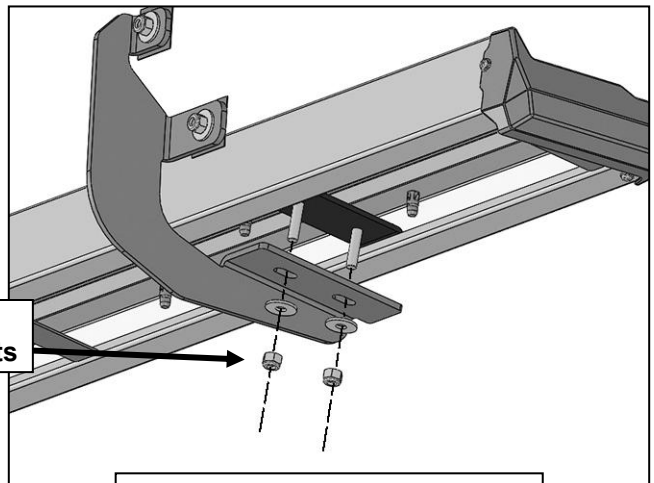

(Fig 7) Attach the Driver/Left Running Board to the Bolt Plate