

PARTS LIST:

| | | | |
|---|---|----|----------------------------------|
| 2 | Running Boards | 12 | 8mm Plastic Washers |
| 4 | Universal Mounting Brackets (left or right) | 20 | 8mm x 24mm OD x 2mm Flat Washers |
| 4 | 8mm x 35mm Double Bolt Plates | 20 | 8mm Nylon Lock Nuts |

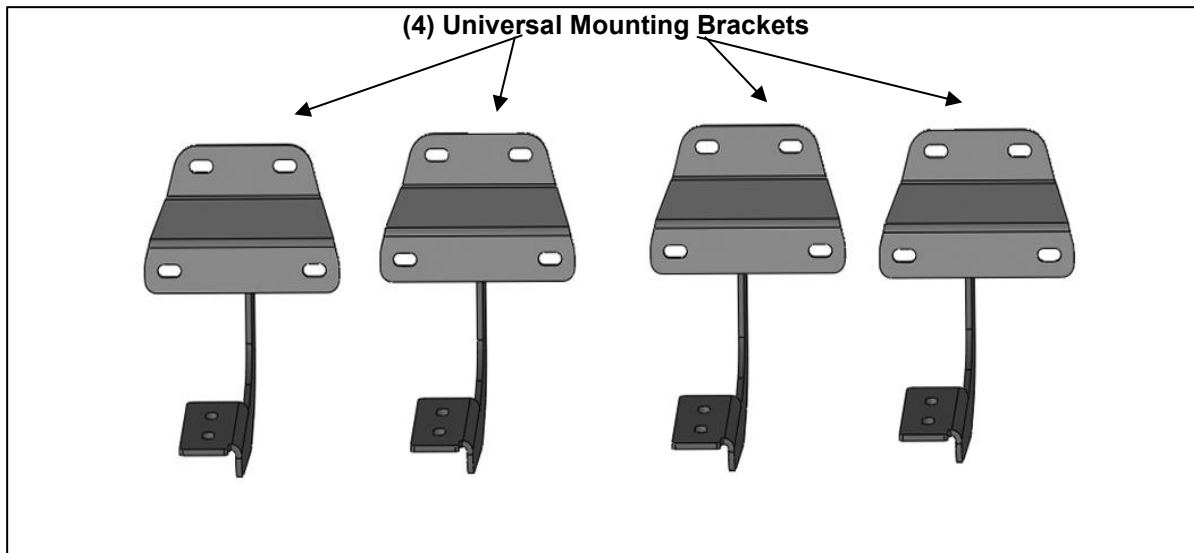

PROCEDURE:

REMOVE CONTENTS FROM BOX. VERIFY ALL PARTS ARE PRESENT. READ INSTRUCTIONS CAREFULLY. ASSISTANCE IS RECOMMENDED.

1. Start the installation under either side of the vehicle. Locate the front factory mounting location along the inner side of the body, (**Figure 1**). Use a wire brush or thread chaser die to remove excess paint and/or undercoating from all studs.
2. Slide (1) Plastic Washer over each of the (3) factory mounting studs in the body panel, (**Figures 2—4**). **IMPORTANT:** The Plastic Washers are designed to prevent corrosion between the aluminum body panel and the steel mounting brackets. **Do not install the Brackets without the Plastic Washers.**
3. Select (1) Mounting Bracket. Attach the Bracket to the studs with (3) 8mm Flat Washers and (3) 8mm Nylon Lock Nuts, (**Figure 4**). Do not tighten hardware.
4. Repeat **Step 3** to attach (1) Mounting Brackets to the rear mounting locations.
5. Select the Running Board. Select (2) Double Bolt Plates. Insert the Bolt Plates into the channel in the bottom of the Running Board closest to the Brackets, (**Figure 5**). Lift the Running Board up and guide the studs through the Brackets.
6. Attach the Running Board to the Mounting Brackets with, (4) 8mm Flat Washers and (4) 8mm Nylon Lock Nuts, (**Figure 6**). Do not tighten hardware.
7. Level and adjust the Running Board and tighten all hardware.
8. Repeat **Steps 1—7** to attach the other Running Board.
9. Do periodic inspections to the installation to make sure that all hardware is secure and tight.

To protect your investment, Do not use any type of polish or wax that may contain abrasives that could damage the finish. Use only mild soap to clean the Running Boards.

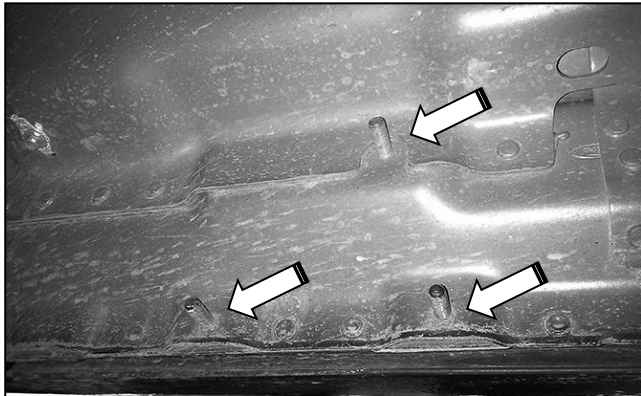

(Fig 1) Example of typical mounting location

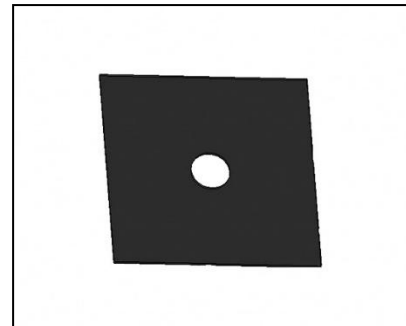

(Fig 2) Plastic Insulation Washer

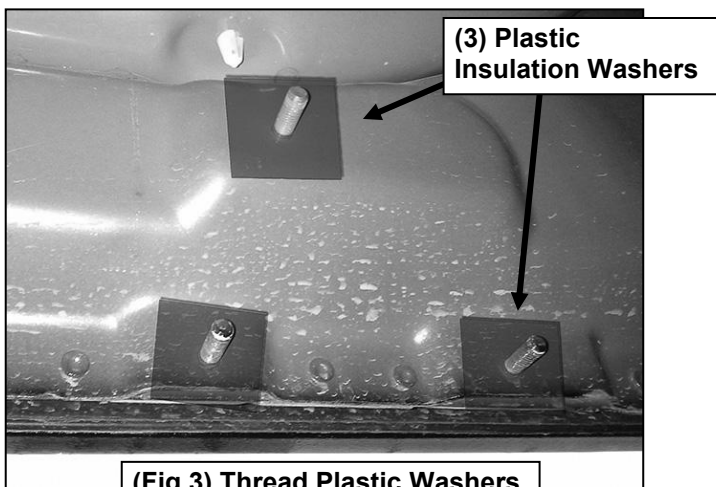

(Fig 3) Thread Plastic Washers onto all mounting studs

- (3) 8mm Plastic Washers
- (3) 8mm Flat Washers
- (3) 8mm Nylon Lock Nuts

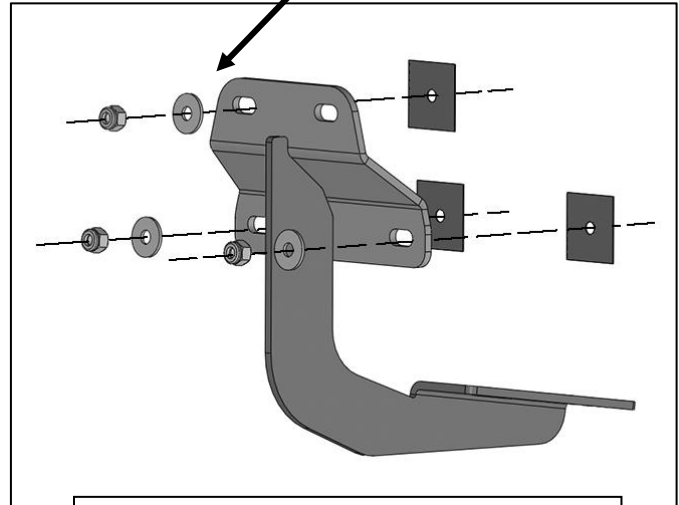

(Fig 4) Attach Bracket to mounting studs

8mm Double Bolt Plate

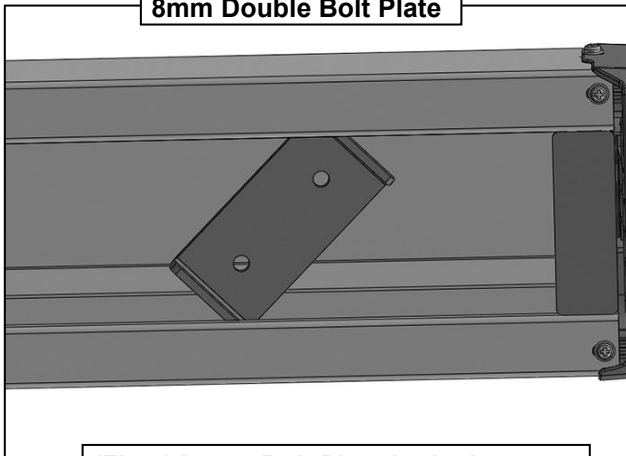

(Fig 5) Insert Bolt Plate in the bottom of the channel on the Running Board

- (2) 8mm Flat Washers
- (2) 8mm Nylon Lock Nuts

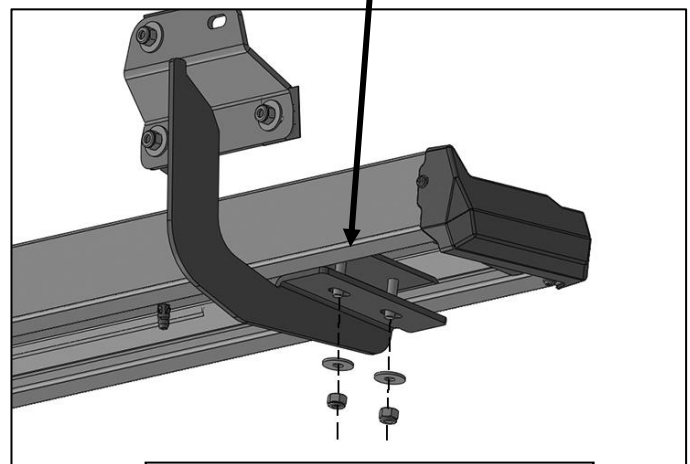

(Fig 6) Attach the Running Board to the Mounting Brackets