

**PARTS LIST:**

2	91" Running Boards	10	8-1.25mm x 35mm Hex Bolts
2	Driver/left Front and Rear Mounting Brackets	10	8-1.25mm x 30mm Hex Bolts
2	Passenger/right Front and Rear Mounting Brackets	10	8mm x 28mm x 3mm Large Flat Washers
1	Driver/left Center Mounting Bracket	32	8mm x 24mm x 2mm Flat Washers
1	Passenger/right Center Mounting Bracket	20	8mm Lock Washers
10	8mm Clip Nuts	10	8-1.25mm Hex Nuts
6	8-1.25mm x 35mm Double Bolt Plates	12	8-1.25mm Nylon Lock Nuts

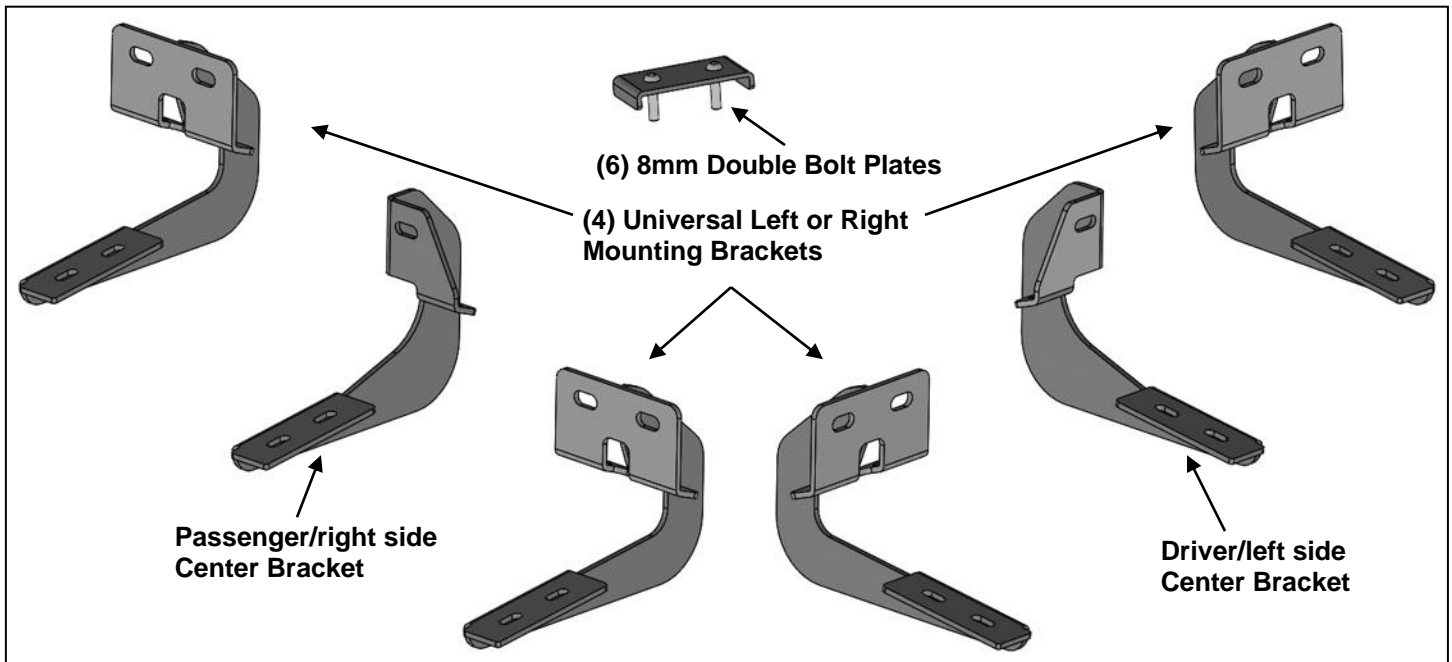

**PROCEDURE:**

- 1. REMOVE CONTENTS FROM BOX. VERIFY ALL PARTS ARE PRESENT. READ INSTRUCTIONS CAREFULLY BEFORE STARTING INSTALLATION.**
- Starting on the driver/left side of the vehicle, locate the (2) holes in the bottom of the body panel, (pinch weld), toward the front tire, **(Figure 1)**. Next locate the rectangular opening and (2) small holes in the inner body panel directly above the holes in the pinch weld, **(Figures 1 & 2)**. **NOTE:** The holes in the inner panel may be covered with sealing tape or insulation.
- Slide (1) 8mm Clip Nut into the rectangular opening with the nut towards the inside. Line up the threaded nut on the clip with the round hole, **(Figure 2)**. Repeat to install the 2nd 8mm Clip Nut in remaining hole location.
- Select (1) Driver side Front/Rear Mounting Bracket. Attach the Bracket to the (2) Clip Nuts with the included (2) 8mm x 30mm Hex Bolts, (2) 8mm Lock Washers and (2) 8mm x 28mm Large Flat Washers, **(Figures 3 & 5)**. **NOTE:** Depending on model and year, the brake cable may be run on the inside or outside of the Bracket. Do not tighten hardware at this time.
- Align the bottom holes in the front Bracket with the (2) holes in the pinch weld. Attach the Bracket to the pinch weld using the included (2) 8mm x 25mm Hex Bolts, (4) 8mm x 24mm STD Flat Washers, (2) 8mm Lock Washers and (2) 8mm Hex Nuts, **(Figures 4 & 5)**. **NOTE:** Insert the bolts up from the bottom of the pinch weld and through the Bracket.
- Move along the cab to the center mounting location, **(Figures 1 & 6)**. Locate the (2) holes in the pinch weld similar to the front location. Insert (1) 8mm Clip Nut into the rectangular opening and up to the single small round hole in the body panel, **(Figure 6)**. Attach the top of the center Bracket to the Clip Nut with (1) 8mm x 30mm Hex Bolt, (1) 8mm Lock Washer and (1) 8mm x 28mm Large Flat Washer, **(Figure 7)**. Line up the hole in the Bracket with the forward hole in the pinch weld. Attach the Bracket to the pinch weld with (1) 8mm x 25mm Hex Bolt, (2) 8mm STD Flat Washers, (1) 8mm Lock Washer and (1) 8mm Hex Nut, **(Figure 7)**. Do not tighten hardware at this time.

7. Continue along the cab to the rear mounting location and locate the last (2) mounting holes in the pinch weld at the back of the cab, **(Figure 1)**. Repeat **Steps 2—5** for rear Bracket installation, **(Figure 8)**.
8. Select (1) Running Board and (3) 8mm Double Bolt Plates. Slide the Bolt Plates into the channel on the bottom of the Running Board, **(Figure 9)**.
9. With assistance, carefully position the Running Board onto the (3) Mounting Brackets. Lift the Running Board up and slide the Bolt Plates along the channels to line up with the Brackets. **IMPORTANT:** Do not slide the Running Board on the Brackets, (front to back or rotate), or the finish on the Running Board may be damaged.
10. Attach the Running Board to the Brackets with (6) 8mm x 24mm STD Flat Washers and (6) 8mm Nylon Lock Nuts, **(Figures 10—12)**. Do not tighten hardware.
11. Level and adjust the Running Board and tighten all hardware.
12. Repeat **Steps 2—11** for passenger/right Running Board installation.
13. Do periodic inspections to the installation to make sure that all hardware is secure and tight.

**To protect your investment**, wax this product after installing. Regular waxing is recommended to add a protective layer over the finish. Do not use any type of polish or wax that may contain abrasives that could damage the finish. Mild soap may be used to clean the Running Board.

### Driver/left Side Installation Pictured

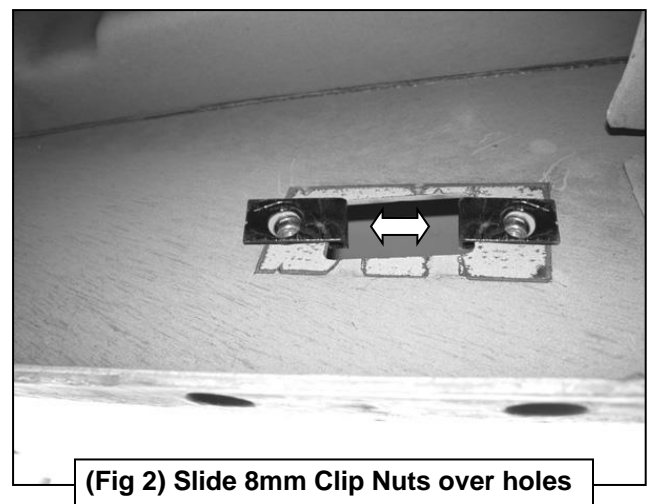
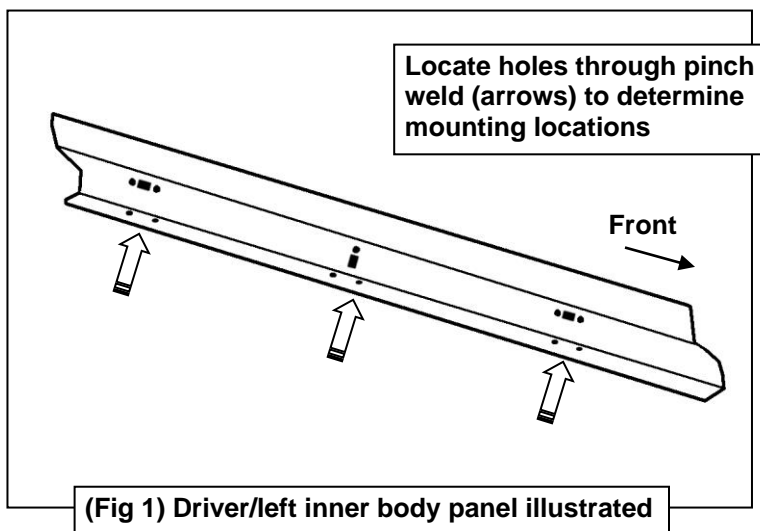

### Driver/left Side Installation Pictured

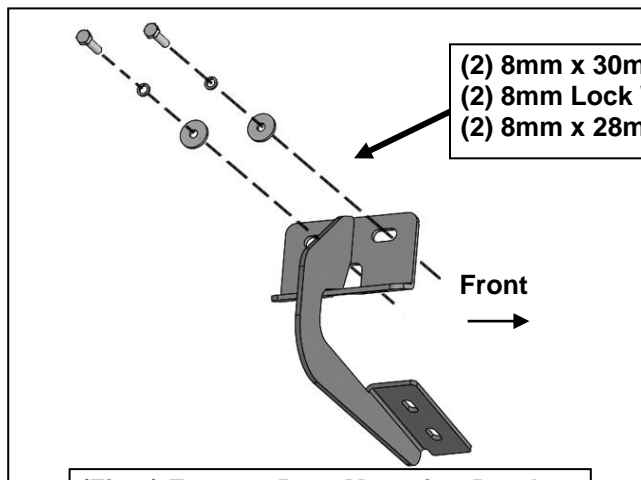

(Fig 3) Front or Rear Mounting Bracket

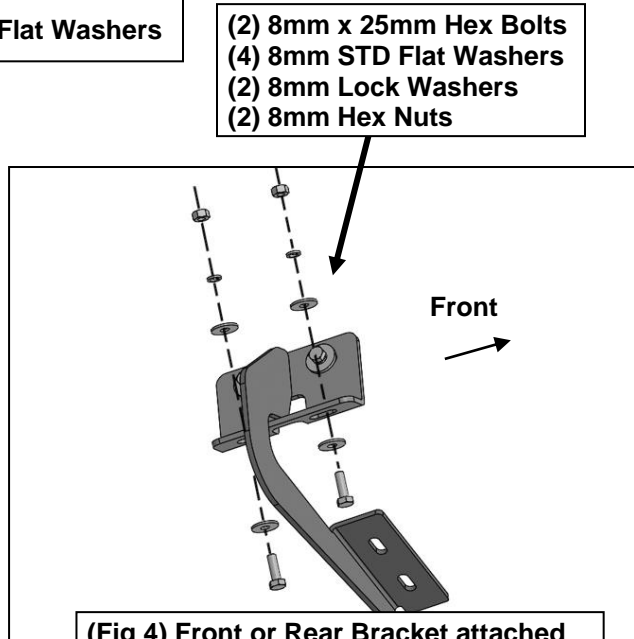

(Fig 4) Front or Rear Bracket attached to pinch weld illustrated

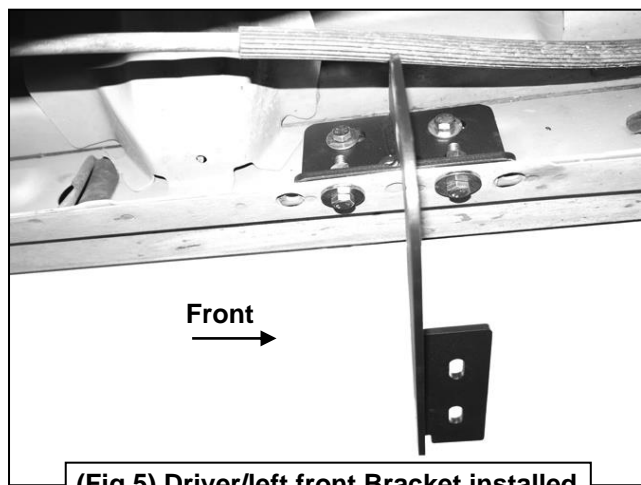

(Fig 5) Driver/left front Bracket installed

- 8mm x 30mm Hex Bolt
- 8mm Lock Washer
- 8mm x 28mm Large Flat Washer



(Fig 6) Driver/left center mounting location

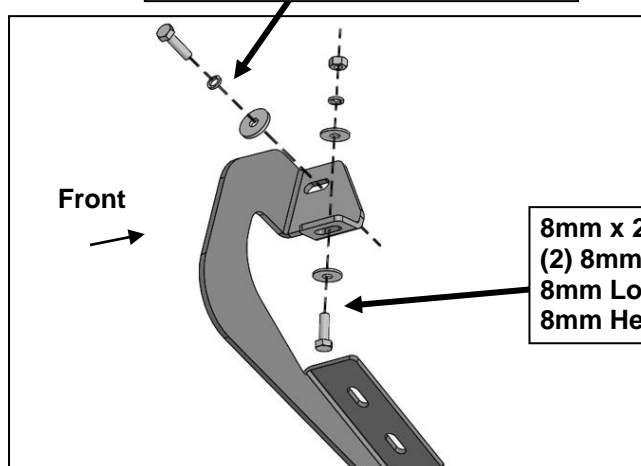

(Fig 7) Driver/left Center Bracket installed

### Driver/left Side Installation Pictured

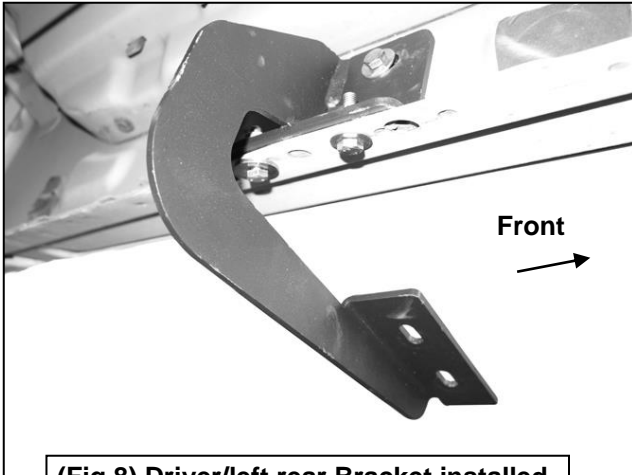

(Fig 8) Driver/left rear Bracket installed

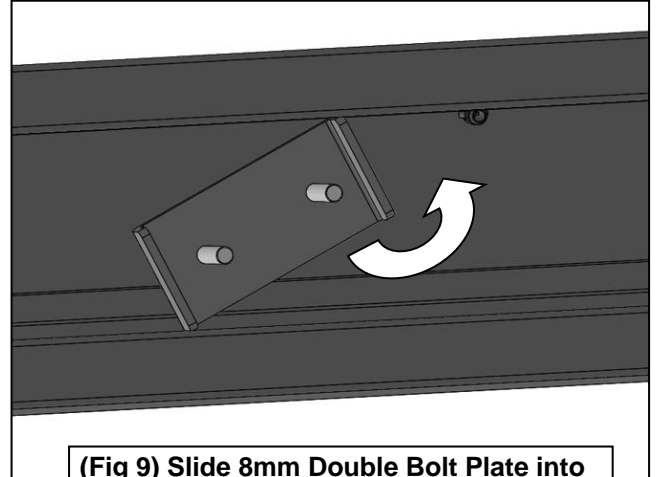

(Fig 9) Slide 8mm Double Bolt Plate into channel on bottom of Running Board

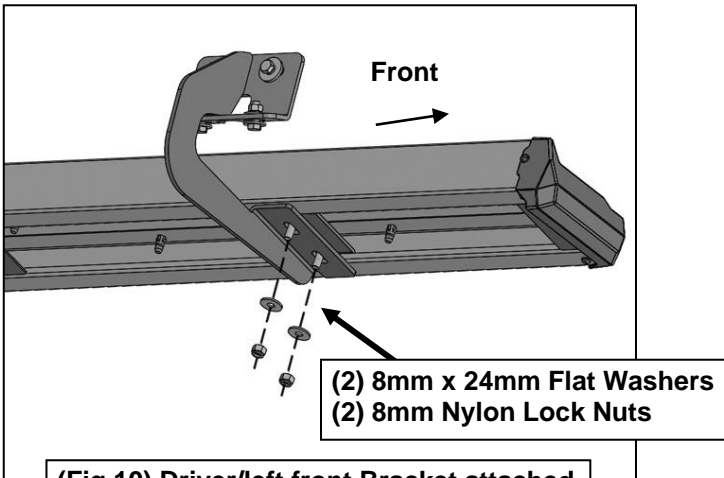

(2) 8mm x 24mm Flat Washers  
(2) 8mm Nylon Lock Nuts

(Fig 10) Driver/left front Bracket attached to Running Board illustrated

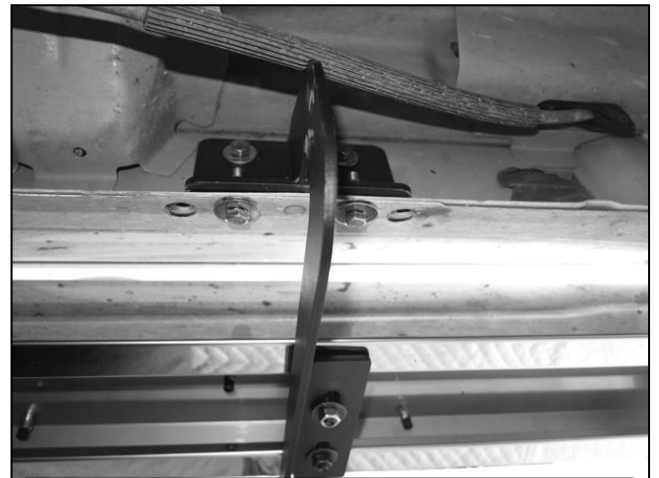

(Fig 11) Driver/left front complete installation



(Fig 12) Driver/left rear complete installation



Complete Installation