

PARTS LIST:

1	79" Driver/left side Running Board	12	8mm x 25mm Hex Bolts
1	79" Passenger/right side Running Board	12	8mm x 28mm x 3mm Flat Washers
3	Driver/left side Mounting Brackets	36	8mm x 24mm x 2mm Flat Washers
3	Passenger/right side Mounting Bracket	24	8mm Lock Washers
6	8-1.25mm Double Bolt Plates	12	8mm Hex Nuts
12	8mm Clip-On Nuts	12	8-1.25mm Nylon Lock Nuts
12	8mm x 30mm Hex Bolts		

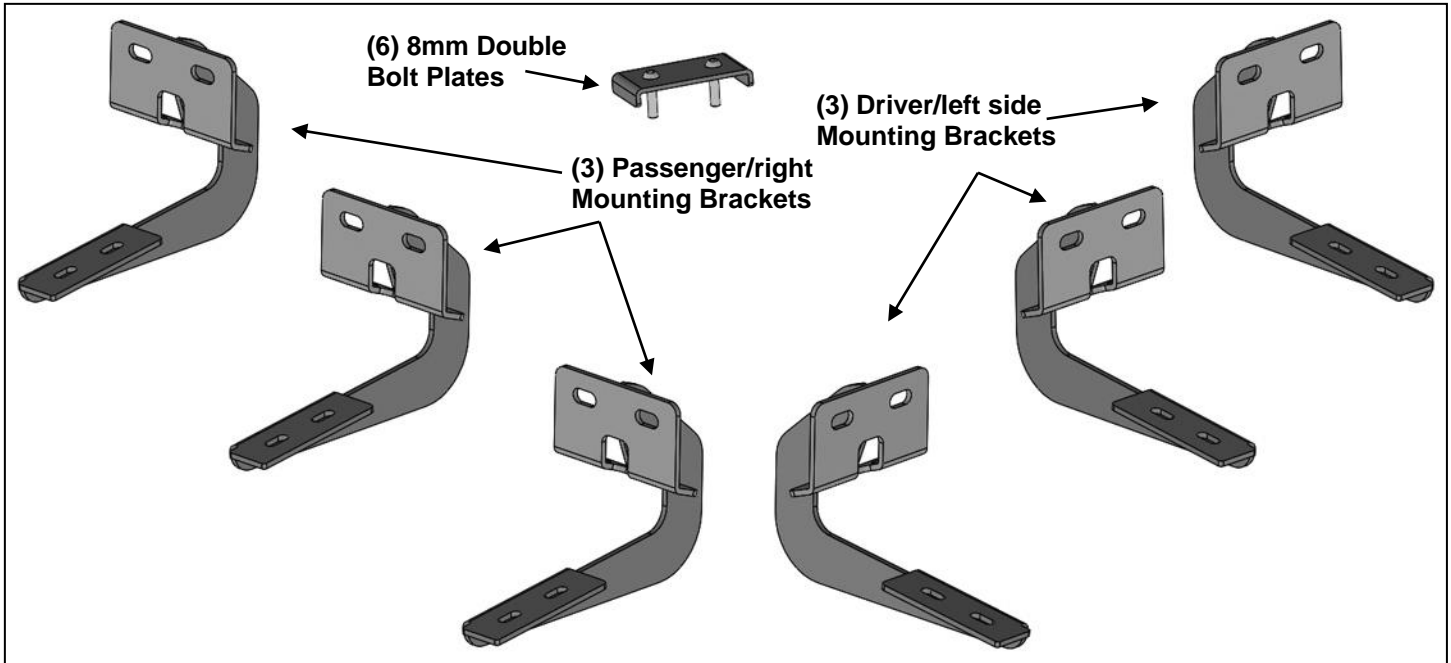

PROCEDURE:

- 1. REMOVE CONTENTS FROM BOX. VERIFY ALL PARTS ARE PRESENT. READ INSTRUCTIONS CAREFULLY BEFORE STARTING INSTALLATION.**
- Starting on the driver/left side front of the vehicle, locate the (2) holes in the bottom of the body panel, (pinch weld), toward the front tire, **(Figures 1 & 2)**. Next locate the rectangular opening and (2) small holes in the inner body panel directly above the holes in the pinch weld, **(Figures 1 & 2)**. **NOTE:** The holes in the inner panel may be covered with sealing tape or insulation.
- Slide (1) 8mm Clip Nut into the rectangular opening with the nut towards the inside. Line up the threaded nut on the clip with the round hole, **(Figure 3)**. Repeat to install the 2nd 8mm Clip Nut in remaining hole location.
- Select (1) Driver/left side Mounting Bracket. Attach the Bracket to the (2) Clip Nuts with the included (2) 8mm x 30mm Hex Bolts, (2) 8mm Lock Washers and (2) 8mm x 28mm Large Flat Washers, **(Figures 4 & 6)**. **NOTE:** Depending on model and year, the brake cable may be run on the outside of the Bracket. Do not tighten hardware at this time.
- Align the bottom holes in the front Bracket with the (2) holes in the pinch weld. Attach the Bracket to the pinch weld using the included (2) 8mm x 25mm Hex Bolts, (4) 8mm x 24mm STD Flat Washers, (2) 8mm Lock Washers and (2) 8mm Hex Nuts, **(Figures 5 & 6)**. **NOTE:** Insert the bolts up from the bottom of the pinch weld and through the Bracket.
- Move to the center mounting location, **(Figure 1)**. Repeat **Steps 2—5** for center Mounting installation.
- Continue along the cab to the rear mounting location and locate the last (2) mounting holes in the pinch weld at the back of the cab, **(Figure 1)**. Repeat **Steps 2—5** for rear Bracket installation, **(Figure 7)**.

8. Select the driver/left side Running Board and (3) 8mm Double Bolt Plates, **(Figure 8)**. **NOTE:** The front stepping pad is farther away from the front end of the Running Board. Place the Running Board on top of the (3) Brackets. Insert the Bolt Plates into the channel in the bottom of the Running Board closest to the Brackets, **(Figure 9)**. Lift the Running Board up and guide the studs down through the Brackets. **IMPORTANT:** Do not slide the Running Board on the Brackets, (front to back or rotate), or the finish on the Running Board may be damaged.
9. Attach the Running Board to the Brackets with (6) 8mm x 24mm Flat Washers and (6) 8mm Nylon Lock Nuts, **(Figures 10—12)**. Do not tighten hardware at this time.
10. Level and adjust the Running Board and tighten all hardware.
11. Repeat **Steps 2—10** for passenger/right side Running Board Installation.
12. Do periodic inspections to the installation to make sure that all hardware is secure and tight.

To protect your investment, wax this product after installing. Regular waxing is recommended to add a protective layer over the finish. Do not use any type of polish or wax that may contain abrasives that could damage the finish. Mild soap may be used to clean the Running Board.

Driver/Left Side Installation Pictured

Locate holes through pinch weld (arrows) to determine mounting locations

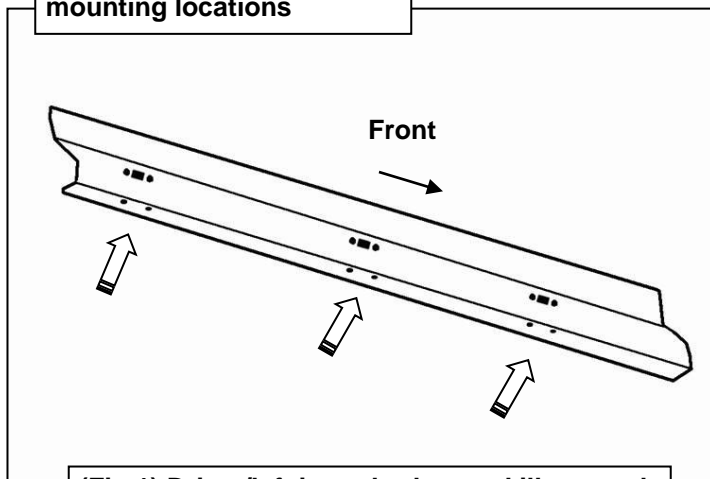

(Fig 1) Driver/left inner body panel illustrated

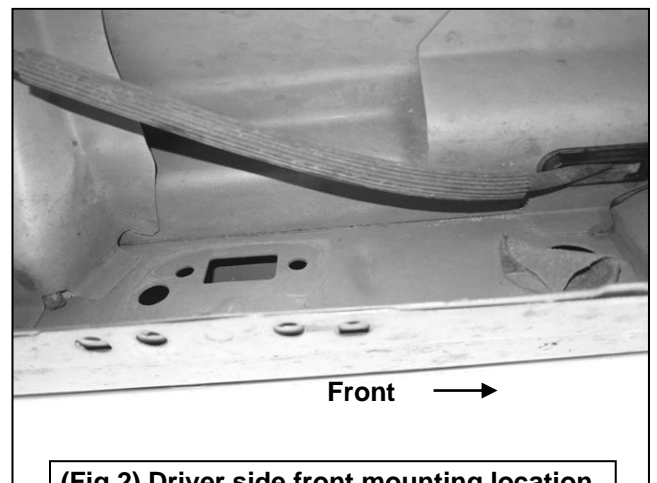

(Fig 2) Driver side front mounting location

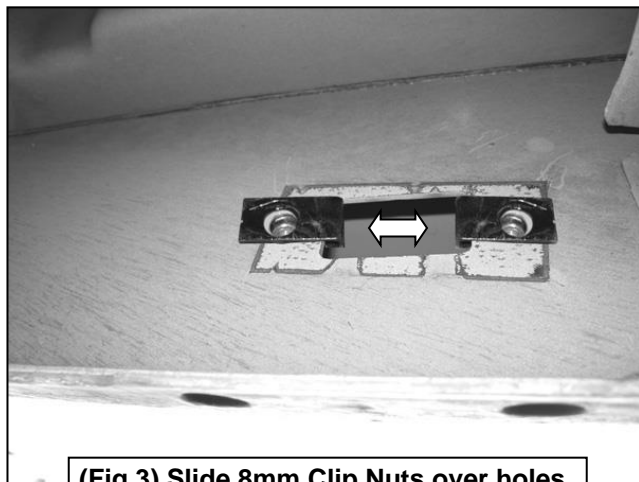

(Fig 3) Slide 8mm Clip Nuts over holes

Driver/Left Side Installation Pictured

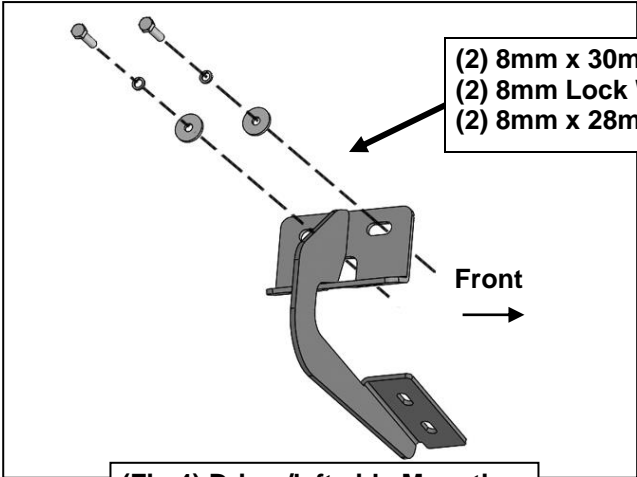

- (2) 8mm x 30mm Hex Bolts
- (2) 8mm Lock Washers
- (2) 8mm x 28mm Large Flat Washers

- (2) 8mm x 25mm Hex Bolts
- (4) 8mm STD Flat Washers
- (2) 8mm Lock Washers
- (2) 8mm Hex Nuts

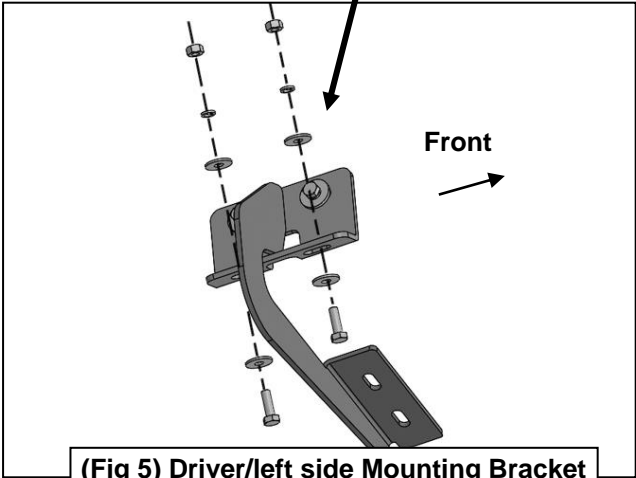

(Fig 5) Driver/left side Mounting Bracket attached to pinch weld illustrated

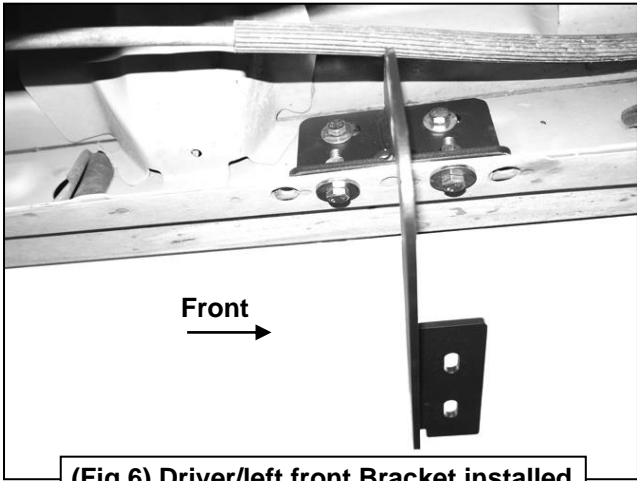

(Fig 6) Driver/left front Bracket installed

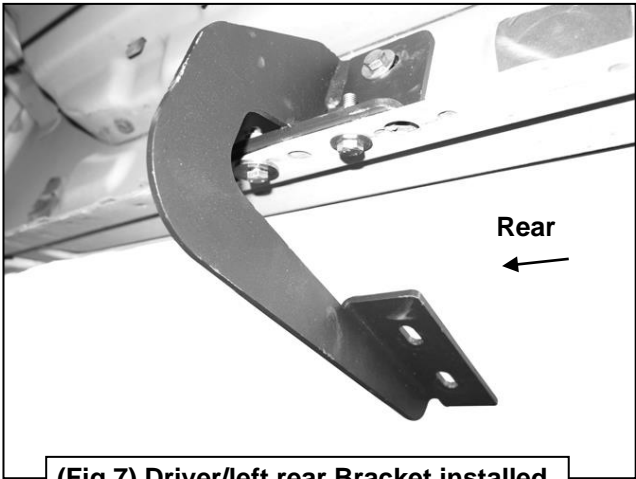

(Fig 7) Driver/left rear Bracket installed

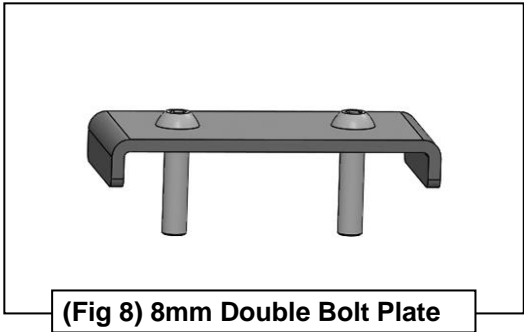

(Fig 8) 8mm Double Bolt Plate

Driver/Left Side Installation Pictured

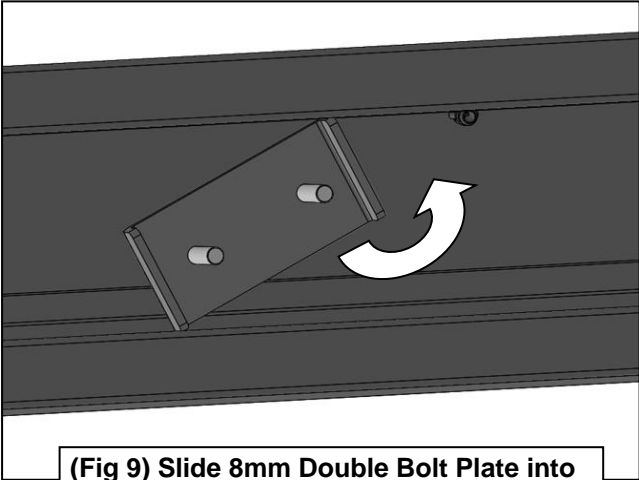

(Fig 9) Slide 8mm Double Bolt Plate into channel on bottom of Running Board

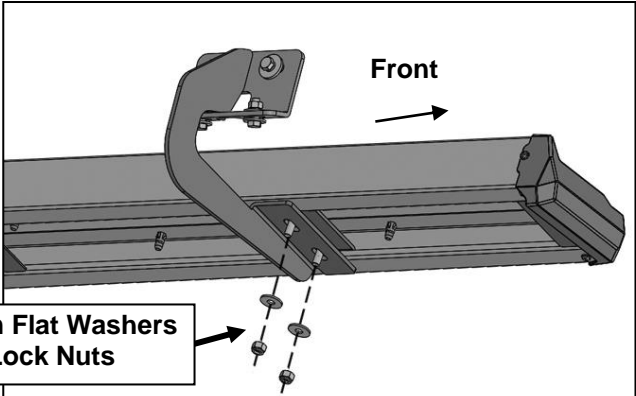

**(2) 8mm x 24mm Flat Washers
(2) 8mm Nylon Lock Nuts**

(Fig 10) Driver/left front Bracket attached to Driver/left Running Board illustrated

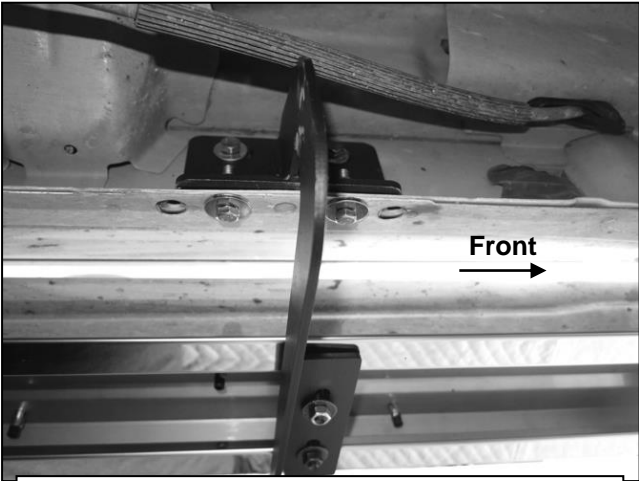

(Fig 11) Driver/left front complete installation



Complete Installation

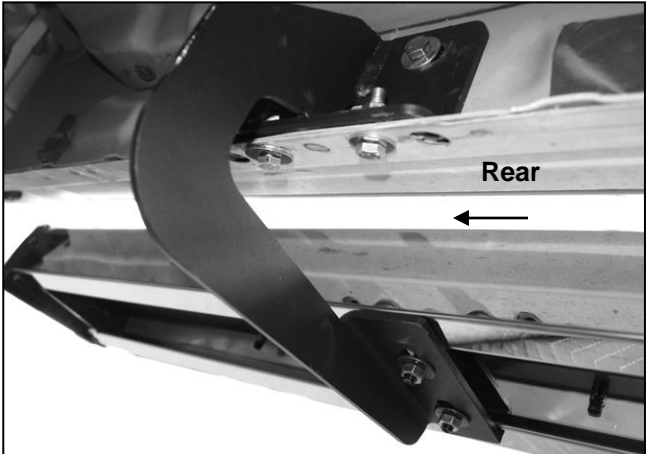

(Fig 12) Driver/left rear complete installation