

PARTS LIST:

| | | | |
|----|-----------------------------------|----|----------------------------------|
| 1 | Driver/Left Tube | 8 | 10mm Lock Washers |
| 1 | Passenger/Right Tube | 16 | 10mm Nylon Lock Nuts |
| 4 | Drop Steps | 8 | 10mm Clip Nuts |
| 4 | Mounting Brackets | 8 | 8mm Triangle Double Bolt Plates |
| 24 | 10mm x 30mm Hex Bolts | 16 | 8mm x 22mm OD x 2mm Flat Washers |
| 24 | 10mm x 27mm OD x 3mm Flat Washers | 16 | 8mm Nylon Lock Nuts |
| 16 | 10mm x 20mm OD x 2mm Flat Washers | | |

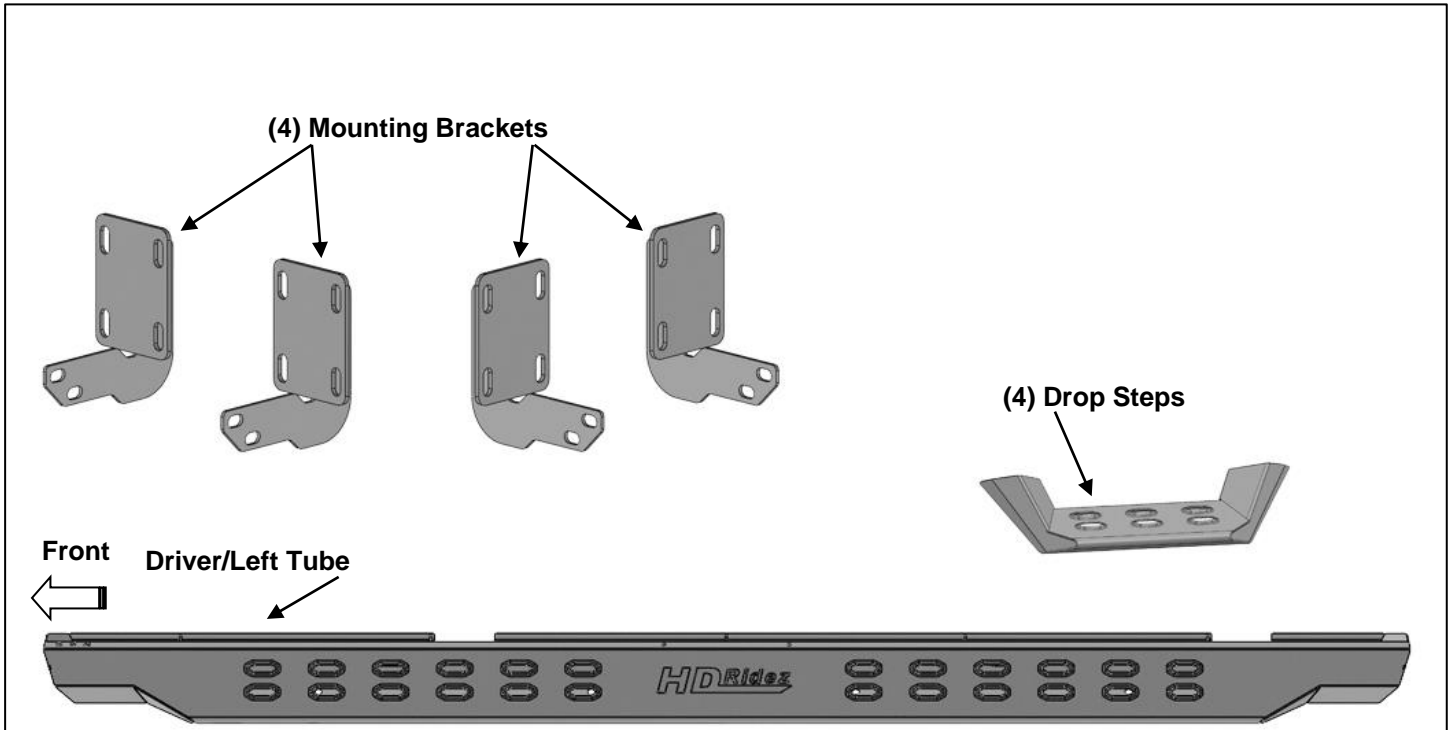

PROCEDURE: REMOVE CONTENTS FROM BOX. VERIFY ALL PARTS ARE PRESENT. READ INSTRUCTIONS CAREFULLY BEFORE STARTING INSTALLATION.

- Starting on the Driver/Left Front side of the vehicle, locate the (2) holes in the Driver/Left Front location in the pinch weld. Next, locate the rectangular opening and the (2) small holes in the inner body panel directly above the holes in the pinch weld, **(Figures 1 & 2)**. **NOTE:** The holes in the inner panel may be covered with sealing tape or insulation, remove as required.
- Slide (2) 10mm Clip Nuts into the rectangular opening with the nut towards the inside. Line up the threaded nut on the clips with the (2) small round holes, **(Figure 3)**.
- Select (1) Driver/Left Mounting Bracket. Attach the top of the Bracket to the Clip Nuts with (2) 10mm Hex Bolts, (2) 10mm Lock Washers and (2) 10mm x 27mm Flat Washers, **(Figure 4)**. Line up the lower holes in the Bracket with the (2) holes through the pinch weld. Bolt the Bracket to the pinch weld with (2) 10mm Hex Bolts, (4) 10mm x 27mm Flat Washers and (2) 10mm Nylon Lock Nuts, **(Figures 4)**. Do not tighten hardware.
- Move toward the rear of the cab, **(Figure 5)**. Locate the last pair of holes along the pinch weld. Use **Figure 1** to determine the correct mounting location for the Bracket. Repeat **Steps 1—3** to attach (1) Mounting Bracket onto the rear location.
- Select the Driver/Left Tube. Insert (2) 8mm Triangle Double Bolt Plates into the front (2) sets of (2) holes, **(Figure 6)**. Attach (1) Drop Step to the (2) Double Bolt Plates with (4) 8mm x 22mm Flat Washers and (4) 8mm Nylon Lock Nuts, **(Figure 7)**. Do not tighten hardware.
- With assistance, line up the mounting tabs in the Driver/Left Tube to the rear faces of the Mounting Brackets. Secure the Tube to the Mounting Brackets with (4) 10mm Hex Bolts, (8) 10mm x 20mm Flat Washers and (4) 10mm Nylon Lock Nuts, **(Figure 8)**. Do not tighten hardware.
- Level and adjust the Overland Slider, then tighten all hardware.

8. Repeat **Steps 1—7** to attach the Passenger/Right Overland Slider.
9. Do periodic inspections to the installation to make sure that all hardware is secure and tight.

To protect your investment, Do not use any type of polish or wax that may contain abrasives that could damage the finish. Mild soap may be used to clean the Overland Sliders.

Driver/Left Side Installation Pictured

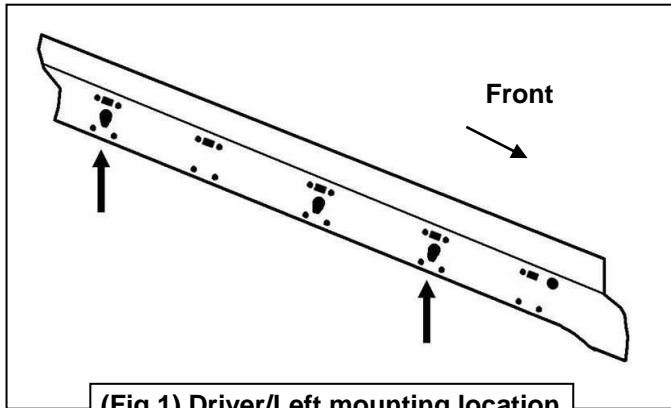

(Fig 1) Driver/Left mounting location

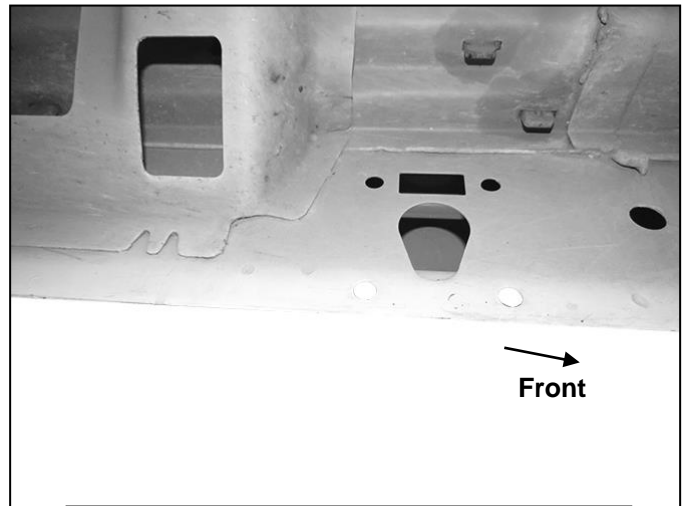

(Fig 2) Driver/Left Front mounting location

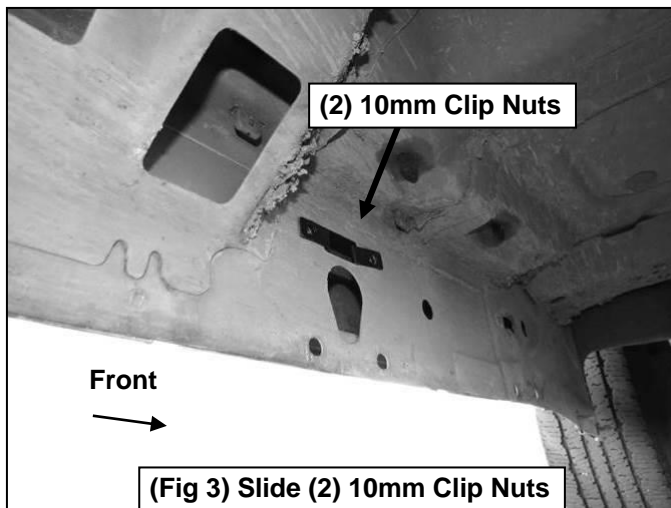

(Fig 3) Slide (2) 10mm Clip Nuts into rectangular opening

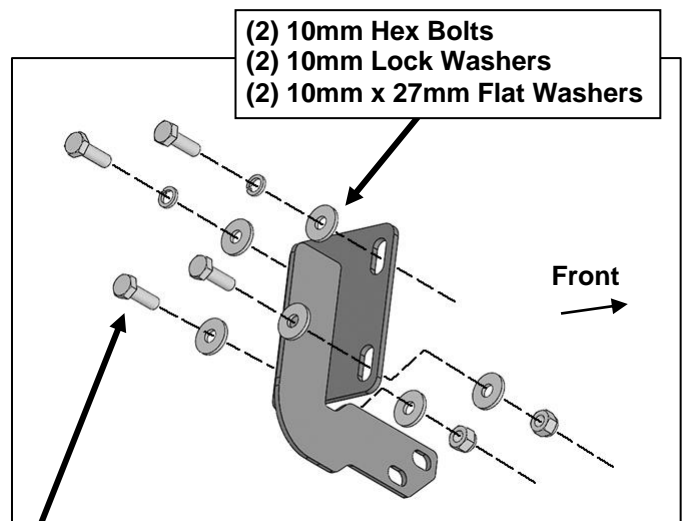

- (2) 10mm Hex Bolts
- (2) 10mm Lock Washers
- (2) 10mm x 27mm Flat Washers

- (2) 10mm Hex Bolts
- (4) 10mm x 27mm Flat Washers
- (2) 10mm Nylon Lock Nuts

(Fig 4) Attach (1) Mounting Bracket to the (2) 10mm Clip Nuts and pinch trim

Driver/Left Side Installation Pictured

