

PARTS LIST:

1	Driver/Left Tube	8	8mm Triangle Double Bolt Plates
1	Passenger/Right Tube	10	8mm x 30mm Hex Bolts
4	Drop Steps	10	8mm x 25mm Hex Bolts
2	Driver/Left Front/Rear Mounting Brackets	10	8mm x 28mm OD x 3mm Flat Washers
2	Passenger/Right Front/Rear Mounting Brackets	36	8mm x 22mm OD x 2mm Flat Washers
1	Driver/Left Center Mounting Bracket	20	8mm Lock Washers
1	Passenger/Right Center Mounting Bracket	10	8mm Hex Nuts
12	10mm x 30mm Hex Bolts	16	8mm Nylon Lock Nuts
24	10mm x 20mm OD x 2mm Flat Washers	10	8mm Clip Nuts
12	10mm Nylon Lock Nuts		

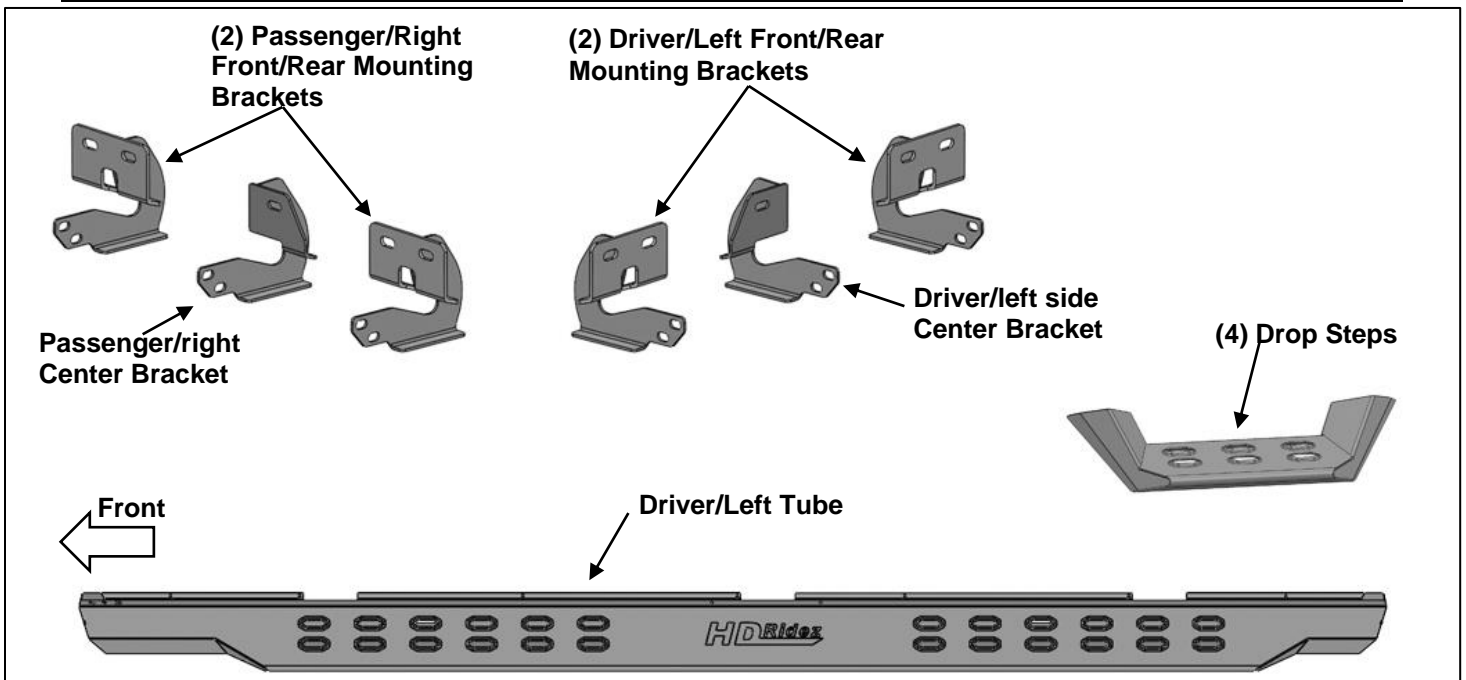

PROCEDURE:

- 1. REMOVE CONTENTS FROM BOX. VERIFY ALL PARTS ARE PRESENT. READ INSTRUCTIONS CAREFULLY BEFORE STARTING INSTALLATION.**
- Starting on the driver/left side of the vehicle, locate the (2) holes in the bottom of the body panel, (pinch weld), toward the front tire, **(Figure 1)**. Next locate the rectangular opening and (2) small holes in the inner body panel directly above the holes in the pinch weld, **(Figures 1 & 2)**. **NOTE:** The holes in the inner panel may be covered with sealing tape or insulation.
- Slide (1) 8mm Clip Nut into the rectangular opening with the nut towards the inside. Line up the threaded nut on the clip with the round hole, **(Figure 2)**. Repeat to install the 2nd 8mm Clip Nut in remaining hole location.
- Select (1) Driver side Front/Rear Mounting Bracket. Attach the Bracket to the (2) Clip Nuts with the included (2) 8mm x 30mm Hex Bolts, (2) 8mm Lock Washers and (2) 8mm x 28mm Large Flat Washers, **(Figure 3)**. **NOTE:** Depending on model and year, the brake cable may be run on the inside or outside of the Bracket. Do not tighten hardware at this time.
- Align the bottom holes in the front Bracket with the (2) holes in the pinch weld. Attach the Bracket to the pinch weld using the included (2) 8mm x 25mm Hex Bolts, (4) 8mm x 24mm STD Flat Washers, (2) 8mm Lock Washers and (2) 8mm Hex Nuts, **(Figure 4)**. **NOTE:** Insert the bolts up from the bottom of the pinch weld and through the Bracket.
- Move along the cab to the center mounting location, **(Figures 1 & 6)**. Locate the (2) holes in the pinch weld similar to the front location. Insert (1) 8mm Clip Nut into the rectangular opening and up to the single small round hole in the body panel, **(Figure 6)**. Attach the top of the center Bracket to the Clip Nut with (1) 8mm x 30mm Hex Bolt, (1) 8mm Lock Washer and (1) 8mm x 28mm Large Flat Washer, **(Figure 7)**. Line up the hole in the Bracket with the forward hole in the pinch weld. Attach the Bracket to

the pinch weld with (1) 8mm x 25mm Hex Bolt, (2) 8mm STD Flat Washers, (1) 8mm Lock Washer and (1) 8mm Hex Nut, **(Figure 7)**. Do not tighten hardware at this time.

7. Continue along the cab to the rear mounting location and locate the last (2) mounting holes in the pinch weld at the back of the cab, **(Figure 1)**. Repeat **Steps 2—5** for rear Bracket installation, **(Figures 3&4)**.
8. Select the Driver/Left Tube. Insert (2) 8mm Triangle Double Bolt Plates into the front (2) sets of (2) holes, **(Figure 8)**. Attach (1) Drop Step to the (2) Double Bolt Plates with (4) 8mm x 22mm Flat Washers and (4) 8mm Nylon Lock Nuts, **(Figure 9)**. Do not tighten hardware.
9. With assistance, line up the mounting tabs in the Driver/Left Tube to the rear faces of the Mounting Brackets. Secure the Tube to the Mounting Brackets with (6) 10mm Hex Bolts, (12) 10mm x 20mm Flat Washers and (6) 10mm Nylon Lock Nuts, **(Figure 10)**. Do not tighten hardware.
10. Level and adjust the Overland Step, then tighten all hardware.
11. Repeat **Steps 1—10** to attach the Passenger/Right Overland Step.
12. Do periodic inspections to the installation to make sure that all hardware is secure and tight.

To protect your investment, Do not use any type of polish or wax that may contain abrasives that could damage the finish. Mild soap may be used to clean the Overland Sliders.

Driver/left Side Installation Pictured

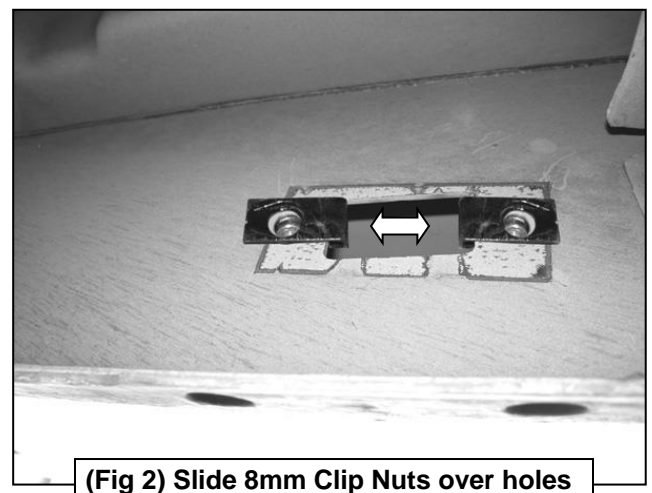
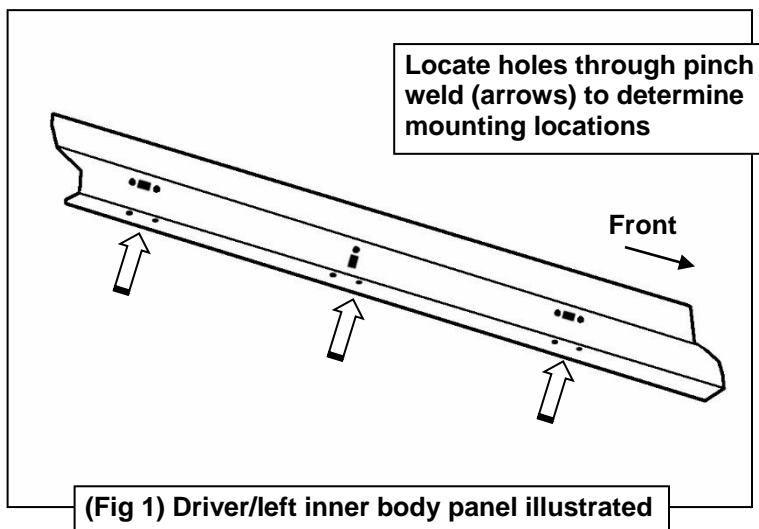

Driver/left Side Installation Pictured

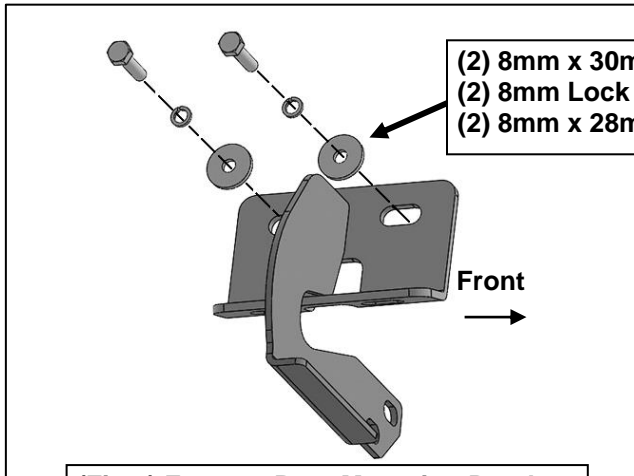

(Fig 3) Front or Rear Mounting Bracket

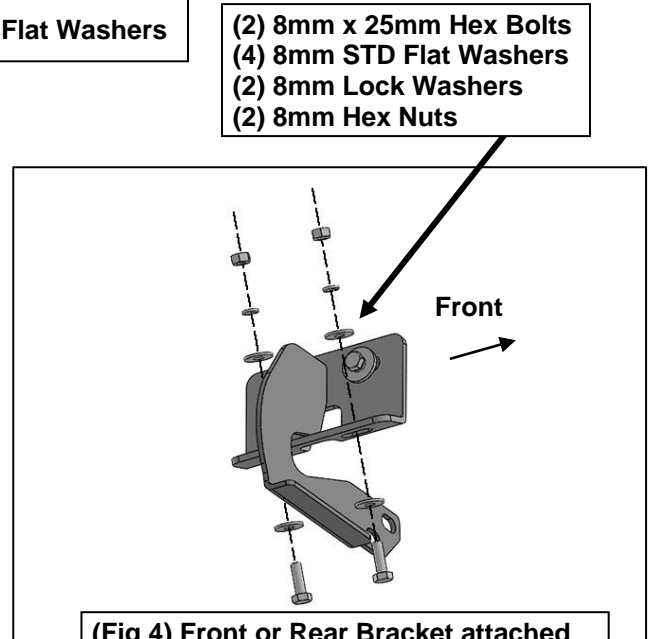

(Fig 4) Front or Rear Bracket attached to pinch weld illustrated



(Fig 6) Driver/left center mounting location

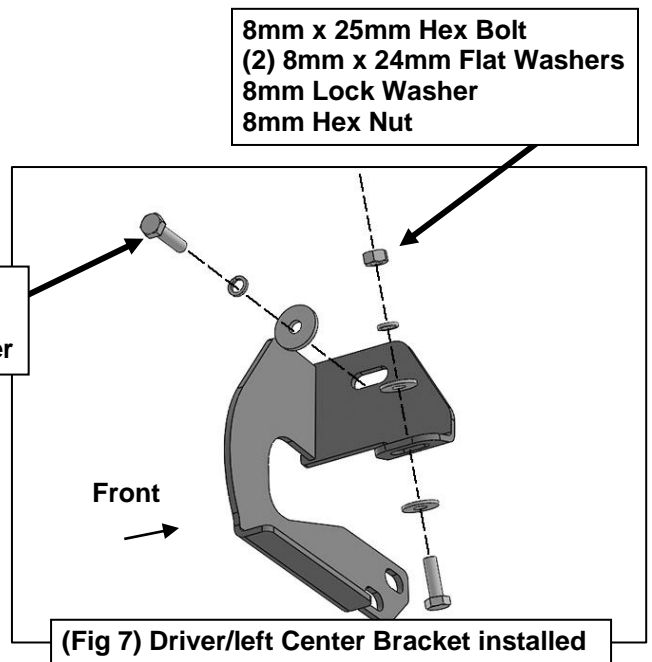

(Fig 7) Driver/left Center Bracket installed

Driver/left Side Installation Pictured

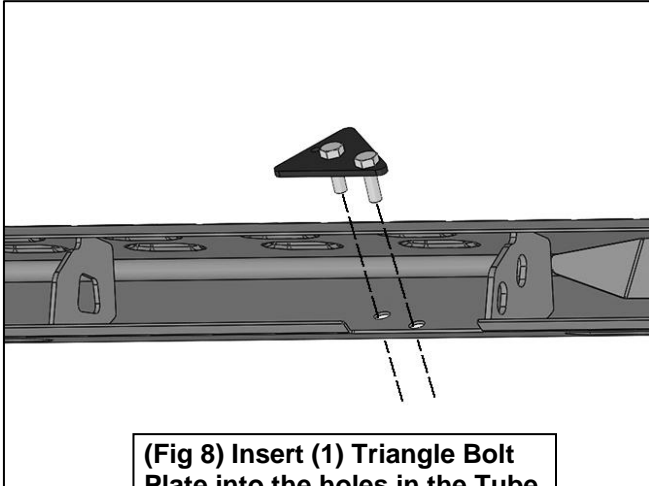

(Fig 8) Insert (1) Triangle Bolt Plate into the holes in the Tube

- 8mm Bolt Plate
- (2) 8mm x 22mm Flat Washers
- (2) 8mm Nylon Lock Nuts

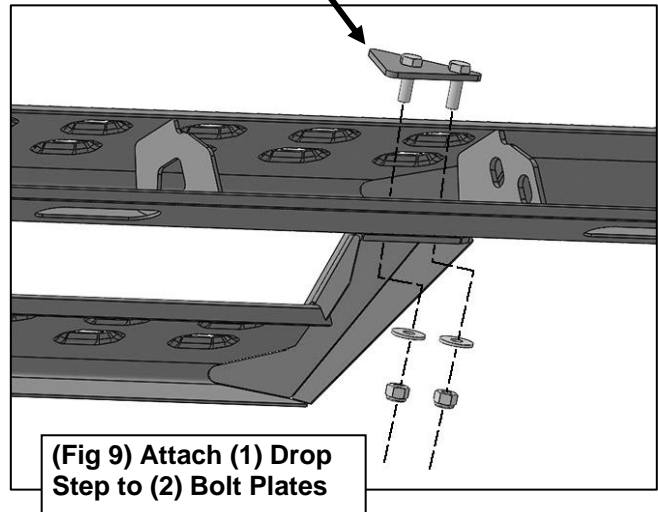

(Fig 9) Attach (1) Drop Step to (2) Bolt Plates

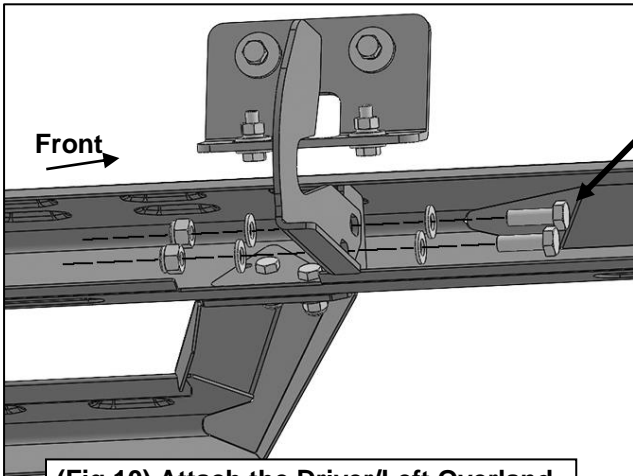

- (2) 10mm Hex Bolts
- (4) 10mm Flat Washers
- (2) 10mm Nylon Lock Nuts

(Fig 10) Attach the Driver/Left Overland Slider to the (3) Mounting Brackets