

PARTS LIST:

1	Driver/Left Tube	12	10mm Nylon Lock Nuts
1	Passenger/Right Tube	8	8mm x 25mm Double Bolt Plates
4	Drop Steps	18	8mm x 24mm OD x 2mm Flat Washers
6	Mounting Brackets	16	8mm x 22mm OD x 2mm Flat Washers
12	10mm x 30mm Hex Bolts	34	8mm Nylon Lock Nuts
24	10mm x 20mm OD x 2mm Flat Washers	18	8mm Plastic Retainers

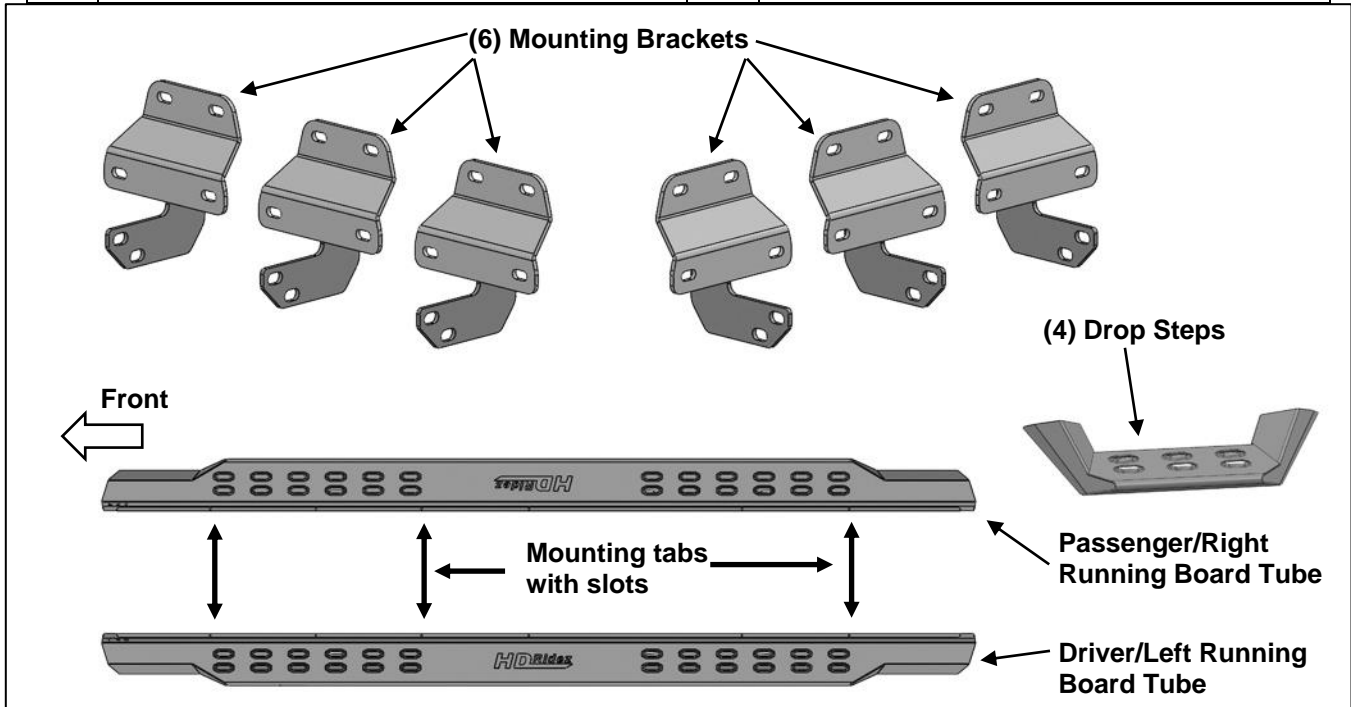

PROCEDURE:

REMOVE CONTENTS FROM BOX. VERIFY ALL PARTS ARE PRESENT. READ INSTRUCTIONS CAREFULLY. ASSISTANCE IS RECOMMENDED.

1. Start the installation under the Passenger/Right side of the vehicle. Locate the front factory mounting location along the inner side of the body, **(Figure 1)**. Use a wire brush or thread chaser die to remove excess paint and/or undercoating from all studs.
2. Slide (1) Plastic Washer over each of the (3) factory mounting studs in the body panel, **(Figures 2 & 3)**. **IMPORTANT:** The Plastic Washers are designed to prevent corrosion between the aluminum body panel and the steel mounting brackets. **Do not install the Brackets without the Plastic Washers.**
3. Select (1) Mounting Bracket, **(Figure 4)**. Attach the Bracket to the (3) studs on the rocker panel with (3) 8mm Flat Washers and (3) 8mm Nylon Lock Nuts, **(Figures 4 & 5)**. Do not tighten hardware.
4. Repeat **Steps 2 & 3** to attach (2) Mounting Brackets to the center and rear mounting locations.
5. Select the Passenger/Right Tube. Insert (2) 8mm Double Bolt Plates into the front (2) sets of (2) holes, **(Figure 6)**. Attach (1) Drop Step to the (2) Double Bolt Plates with (4) 8mm Flat Washers and (4) 8mm Nylon Lock Nuts, **(Figure 7)**. Do not tighten hardware.
6. With assistance, line up the mounting tabs in the Passenger/Right Tube to the rear faces of the Mounting Brackets. Secure the Tube to the Mounting Brackets with (6) 10mm Hex Bolts, (12) 10mm Flat Washers and (6) 10mm Nylon Lock Nuts, **(Figure 8)**. Do not tighten hardware.
7. Level and adjust the Running Board, then tighten all hardware.
8. Repeat **Steps 1—7** to attach the Driver/Left Running Board.
9. Do periodic inspections to the installation to make sure that all hardware is secure and tight.

To protect your investment, Do not use any type of polish or wax that may contain abrasives that could damage the finish. Use only mild soap to clean the Running Boards.

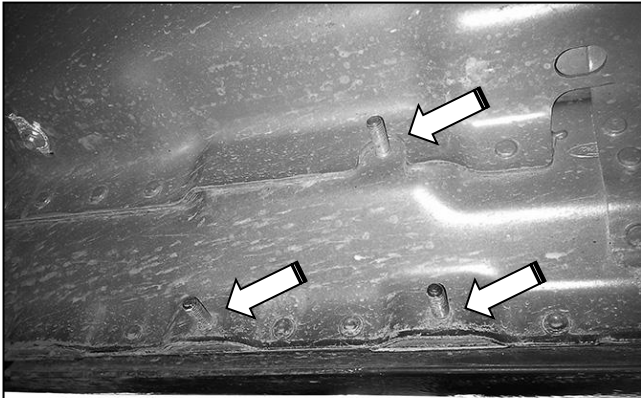

(Fig 1) Example of typical mounting location

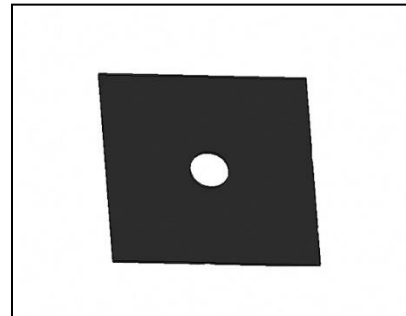

(Fig 2) Plastic Insulation Washer

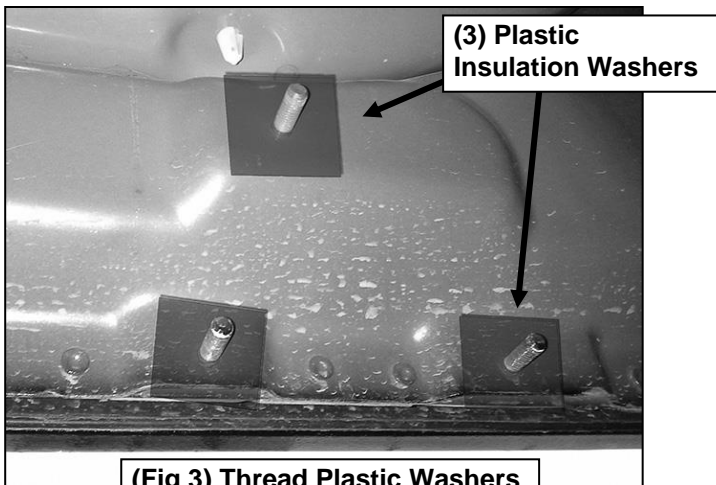

(Fig 3) Thread Plastic Washers onto all mounting studs

- (3) 8mm Plastic Washers
- (3) 8mm Flat Washers
- (3) 8mm Nylon Lock Nuts

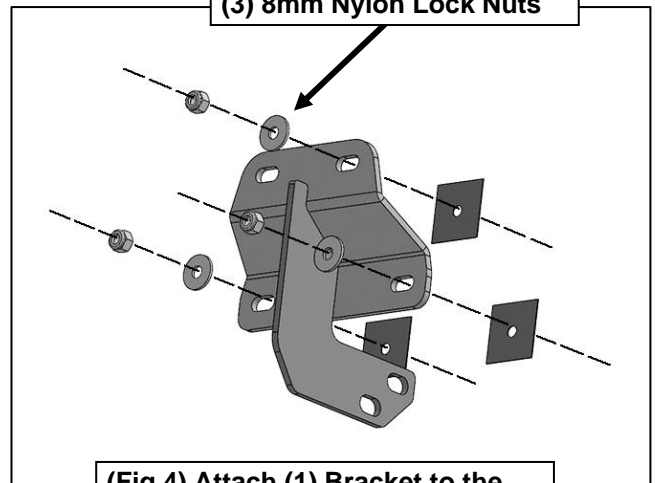

(Fig 4) Attach (1) Bracket to the mounting location

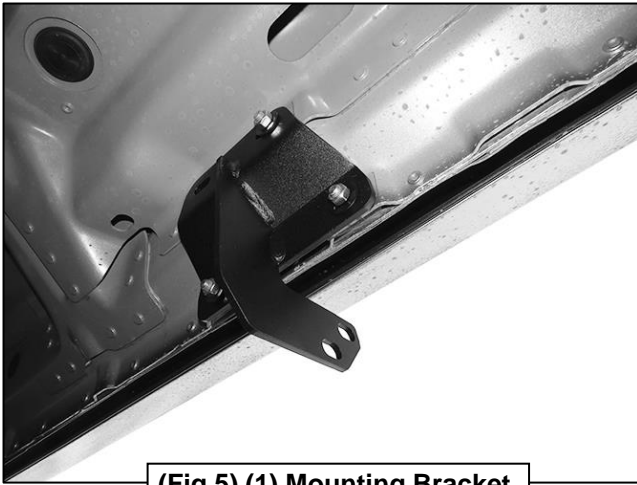

(Fig 5) (1) Mounting Bracket attached to the rocker panel

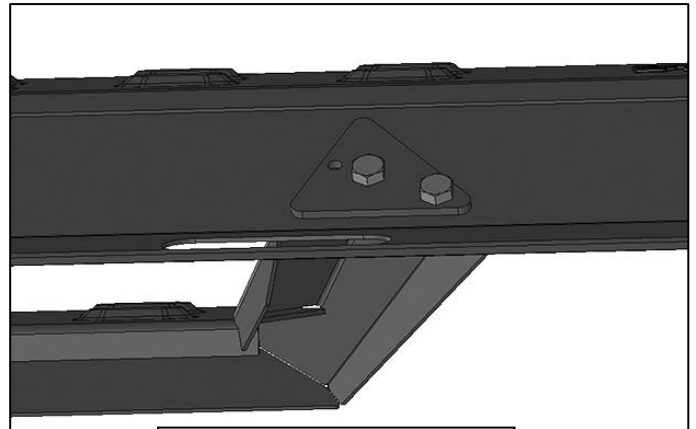

(Fig 6) Insert (1) Bolt Plate into the holes in the Tube

- 8mm Bolt Plate
- (2) 8mm Flat Washers
- (2) 8mm Nylon Lock Nuts

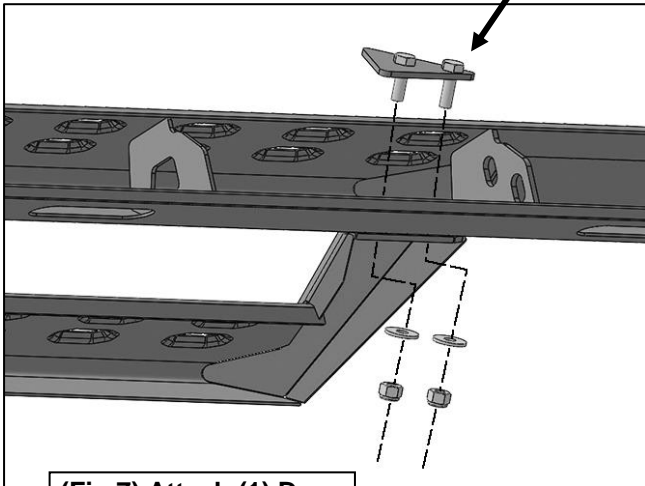

(Fig 7) Attach (1) Drop Step to (2) Bolt Plates

- (2) 10mm Hex Bolts
- (4) 10mm Flat Washers
- (2) 10mm Nylon Lock Nuts

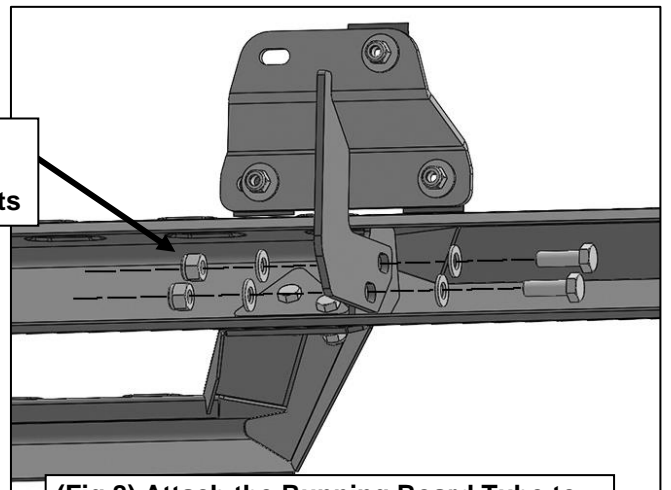

(Fig 8) Attach the Running Board Tube to the rear faces of the (3) Mounting Brackets