

PARTS LIST:

1	Driver/Left Running Board	12	10mm Nylon Lock Nuts
1	Passenger/Right Running Board	18	8mm x 24mm OD x 2mm Flat Washers
6	Mounting Brackets	18	8mm Nylon Lock Nuts
12	10mm x 30mm Hex Bolts	18	8mm Plastic Retainers
24	10mm x 20mm OD x 2mm Flat Washers		

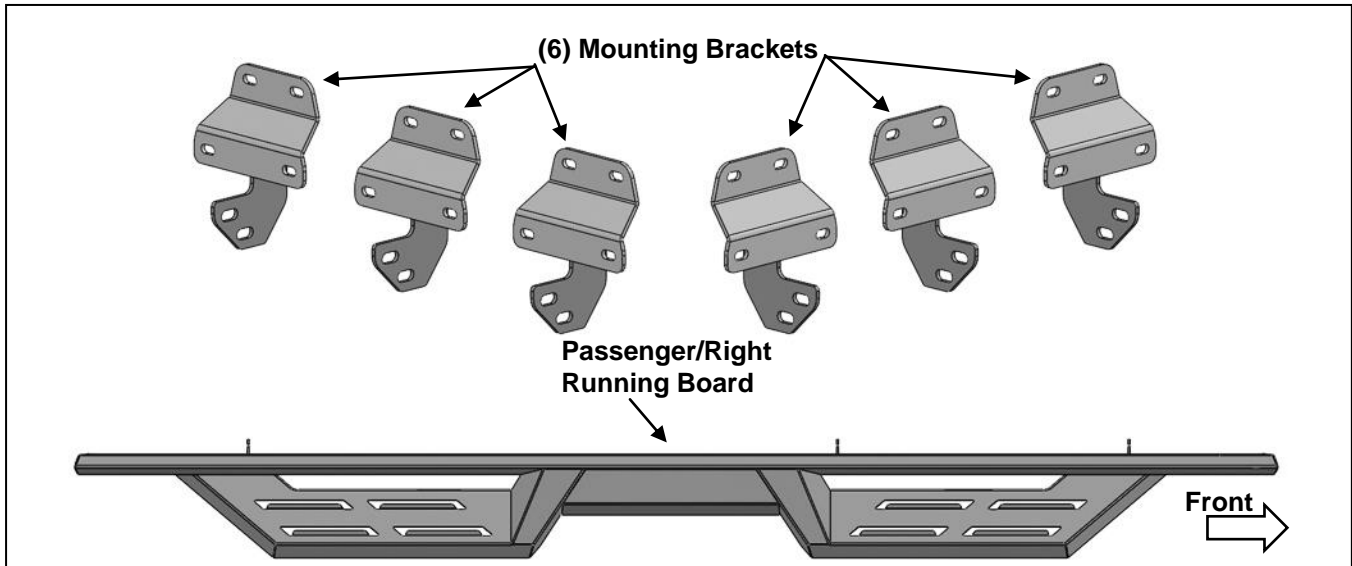

PROCEDURE:

REMOVE CONTENTS FROM BOX. VERIFY ALL PARTS ARE PRESENT. READ INSTRUCTIONS CAREFULLY. ASSISTANCE IS RECOMMENDED.

1. Start the installation under the Passenger/Right side of the vehicle. Locate the front factory mounting location along the inner side of the body, **(Figure 1)**. Use a wire brush or thread chaser die to remove excess paint and/or undercoating from all studs.
2. Slide (1) Plastic Washer over each of the (3) factory mounting studs in the body panel, **(Figures 2—4)**. **IMPORTANT:** The Plastic Washers are designed to prevent corrosion between the aluminum body panel and the steel mounting brackets. **Do not install the Brackets without the Plastic Washers.**
3. Select (1) Mounting Bracket. Attach the Bracket to the studs with (3) 8mm Flat Washers and (6) 8mm Nylon Lock Nuts, **(Figure 4)**. Do not tighten hardware.
4. Repeat **Step 3** to attach the (2) Passenger/Right Rear Mounting Brackets to the center and rear mounting locations.
5. Select the Passenger/Right Running Board. Attach the Running Board to the rear face of the Mounting Brackets with (6) 10mm Hex Bolts, (12) 10mm Flat Washers and (6) 10mm Nylon Lock Nuts, **(Figure 5)**. Do not tighten hardware.
6. Level and adjust the Running Board and tighten all hardware.
7. Repeat **Steps 1—6** to attach Driver/Left Running Board.
8. Do periodic inspections to the installation to make sure that all hardware is secure and tight.

To protect your investment, Do not use any type of polish or wax that may contain abrasives that could damage the finish. Use only mild soap to clean the Running Boards.

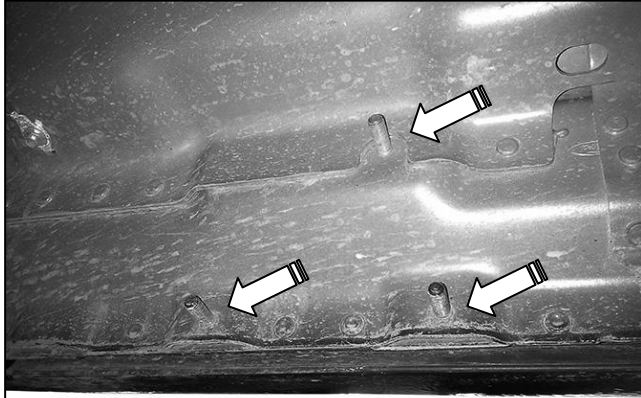

(Fig 1) Example of typical mounting location

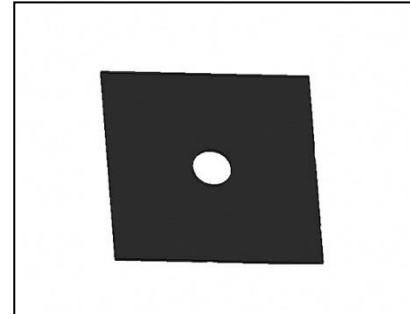

(Fig 2) Plastic Insulation Washer

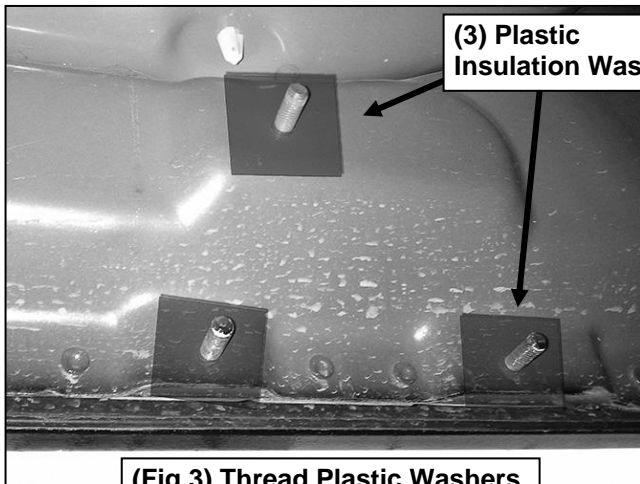

(3) Plastic Insulation Washers

(Fig 3) Thread Plastic Washers onto all mounting studs

(3) 8mm Plastic Washers
(3) 8mm Flat Washers
(3) 8mm Nylon Lock Nuts

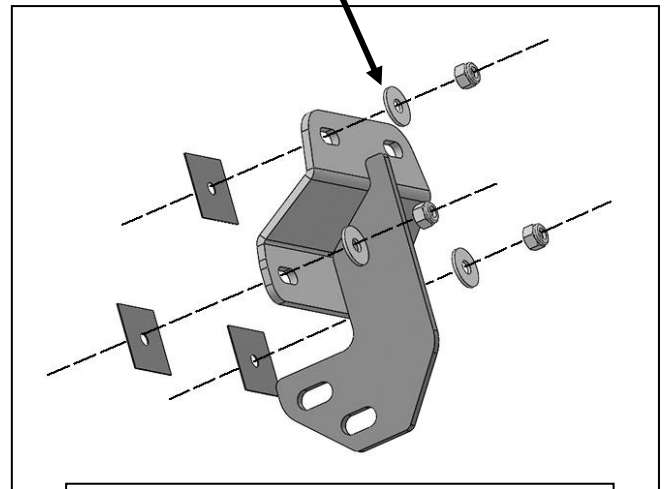

(Fig 4) Attach Bracket to mounting studs

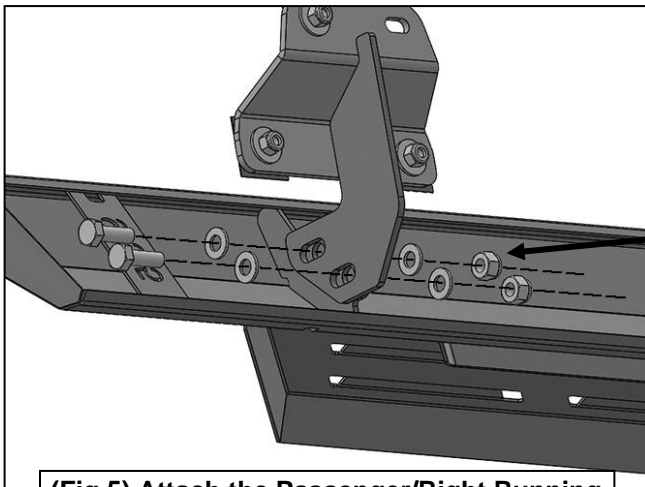

(Fig 5) Attach the Passenger/Right Running Board to the Mounting Brackets

(2) 10mm Hex Bolts
(4) 10mm Flat Washers
(2) 10mm Nylon lock Nuts