

PARTS LIST:

2	Running Boards	4	8mm Plastic Retainers
1	Driver/left Front Mounting Bracket	12	8mm x 30mm Hex Bolts
1	Passenger/right Front Mounting Bracket	24	8mm x 24mm OD x 2mm Flat Washers
1	Driver/left Rear Mounting Bracket	8	8mm Lock Washers
1	Passenger/right Rear Mounting Bracket	4	8mm Hex Nuts
2	Support Brackets (DS Front & PS Rear)	12	8mm Nylon Lock Nuts
2	Support Brackets (PS Front & DS Rear)	8	6mm x 25mm Hex Bolts
4	8mm x 35mm Double Bolt Plates	16	6mm x 22mm OD x 2mm Flat Washers
4	8mm x 30mm Bolt-Nut Plates	8	6mm Nylon Lock Nuts

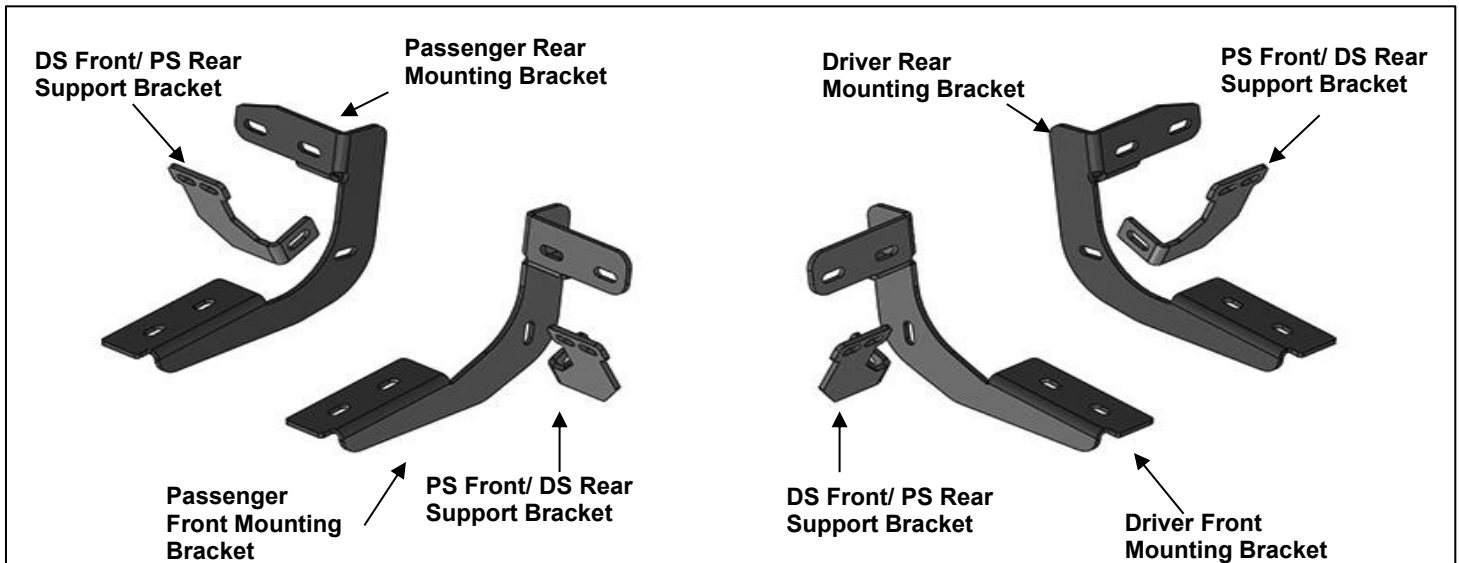

PROCEDURE:

1. REMOVE CONTENTS FROM BOX. VERIFY ALL PARTS ARE PRESENT. READ INSTRUCTIONS CAREFULLY BEFORE STARTING INSTALLATION. DRILLING MAY BE REQUIRED.
2. Starting at the driver/left front of the vehicle, remove the sealing tape covering the factory holes in the side of the inner panel, **(Figure 1)**.
3. Determine the correct procedure to attach the driver/left front Bracket for your model/year:

Models without factory threaded inserts in body panel:

 - a. Partially thread (1) 8mm Hex Bolt into the threaded end of an 8mm Bolt-Nut Plate, **(Figure 2)**. Thread the Hex Bolt in until it is flush with the welded nut, **(Figure 3)**. Use the Hex Bolt as a handle and insert the Bolt- Nut Plate into the oval hole, **(Figure 4)**. Feed the threaded bolt on the Plate through one of the hex shaped factory holes. Thread (1) 8mm Plastic Retainer onto the threaded end and down tight against the body panel, **(Figure 5)**. **NOTE:** The Plastic Retainer is designed to keep the Bolt-Nut Plate from falling into the body panel and to aid in Bracket installation.
 - b. Select the driver/left front Mounting Bracket, **(Figure 6)**. Attach the Bracket to the threaded end of the Bolt-Nut Plate with (1) 8mm Flat Washer, (1) 8mm Lock Washer and (1) 8mm Hex Nut, **(Figure 7)**. Do not tighten.
 - c. Remove the 8mm Hex Bolt from the nut on the Bolt-Nut Plate from **Step 3a**. Rotate the Bolt on the Bolt Plate until the threaded nut lines up with the remaining hole in the Mounting Bracket and body panel, **(Figure 8)**. Attach the Bracket to the threaded nut on the Plate with (1) 8mm x 30mm Hex Bolt, (1) 8mm Lock Washer and (1) 8mm Flat Washer. Do not tighten hardware.

Models with factory threaded inserts:

 - a. Attach the driver Front Bracket to the threaded inserts with (2) 8mm x 30mm Hex Bolts, (2) 8mm Lock Washers and (2) 8mm Flat Washers, **(Figures 9 & 10)**. Leave hardware loose.

4. Next, select the driver/left front Support Bracket. Attach the Bracket to the front facing side of the front Bracket with (1) 8mm x 30mm Hex Bolt, (2) 8mm Flat Washers and (1) 8mm Nylon Lock Nut, (**Figure 11**). Rotate the Support Bracket to the back of the pinch weld. Line up the slots in the top of the Support Bracket with the (2) factory holes in the pinch weld. Attach the Bracket to the back of the pinch weld with (2) 6mm x 25mm Hex Bolts, (4) 6mm Flat Washers and (2) 6mm Nylon Lock Nuts, (**Figures 12 & 13**). Do not fully tighten hardware. **IMPORTANT:** Some **2009-12** models are not equipped with factory holes and will require drilling through the pinch weld to attach the Support Bracket. Do not drill through pinch weld, (**see Step 9**).
5. Move to the rear location, (**Figure 14**). Repeat **Step 3** to install the Driver/left Rear Mounting Bracket, (**Figure 15**). Select the driver/left Rear Support Bracket, (**Figure 15**). Repeat **Step 4** to attach the Support Bracket to the rear facing side of the rear Bracket and factory holes (if equipped) in the pinch weld, (**Figure 16**). **IMPORTANT:** The rear bracket is different from the front Brackets, (see illustration above-note direction of mounting plate).
6. Once all Brackets have been installed, select (1) Running Board. Select (2) Double Bolt Plates. Insert the Bolt Plates into the channel in the bottom of the Running Board closest to the Brackets, (**Figure 17**). Lift the Running Board up and guide the studs through the Brackets. **IMPORTANT:** Do not slide, (front to back), the Running Board on the Brackets or damage to the finish may result.
7. With assistance, carefully position the Running Board onto the (2) Mounting Brackets. **IMPORTANT:** Do not slide the Running Board on the Brackets, (front to back), or the finish on the Running Board may be damaged.
8. Attach the Running Board to the Mounting Brackets using (4) 8mm Flat Washers and (4) 8mm Nylon Lock Nuts, (**Figures 18—19**). Do not tighten hardware.
9. Properly level and adjust the Running Board and fully tighten all hardware.
2009-12 models requiring drilling for Support Brackets:
 - a. Make sure the Running Board is level to the vehicle. Adjust and tighten all mounting hardware.
 - b. Line up the slots on the Support Brackets with the back of the pinch weld. Mark the location of the slots onto the pinch weld.
 - c. Drill (2) 1/4" holes through the pinch weld for each Support Bracket. **IMPORTANT:** Do not drill too close to the bottom edge of the pinch weld. Adjust the Brackets as necessary to move the slots up the body panel away from the edge. Drill the holes toward the outside of the marked slots.
 - d. Attach each Support Bracket to the pinch weld with (2) 6mm Hex Bolts, (4) 6mm Flat Washers and (2) 6mm Nylon Lock Nuts, (**Figure 12**). Check for level then fully tighten all hardware.
10. Move to the passenger side of the vehicle. Remove tape covering front, center and rear locations. Repeat **Steps 2—9** for to attach the other Running Board to the Passenger/right. **NOTE:** Refer to the illustration on **Page 1** to identify the correct Mounting Bracket for each of the remaining locations.
11. Do periodic inspections to the installation to make sure that all hardware is secure and tight.

To protect your investment: Do not use any type of polish or wax that may contain abrasives that could damage the finish. Mild soap may be used to clean the Running Board.

Driver Side Installation Pictured

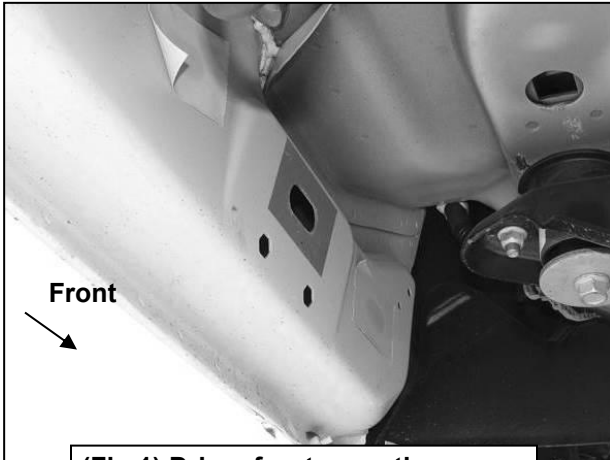

(Fig 1) Driver front mounting location (No factory holes in pinch weld 2009-2012 models)

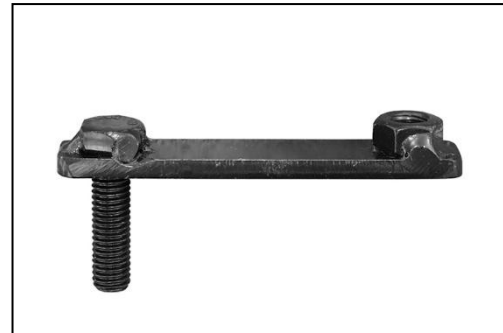

(Fig 2) 8mm Bolt-8mm Nut Plate, NOTE: 8mm Bolt-Nut Plate is not required on models with threaded inserts

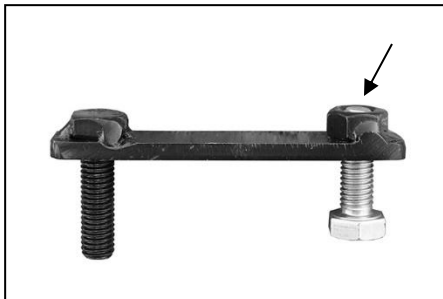

(Fig 3) Thread (1) 8mm Hex Bolt into the nut on the plate. Stop when bolt reaches end of nut as pictured

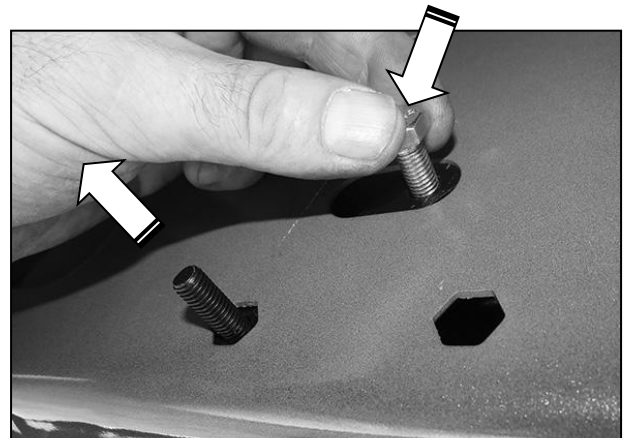

(Fig 4) Use the loose Hex Bolt as a handle. Insert the Bolt Plate into the oval hole and feed the threaded end out either factory hex shaped hole. IMPORTANT: Do not let go of the hex bolt until after Plastic Retainer has been threaded onto bolt (Fig 5)

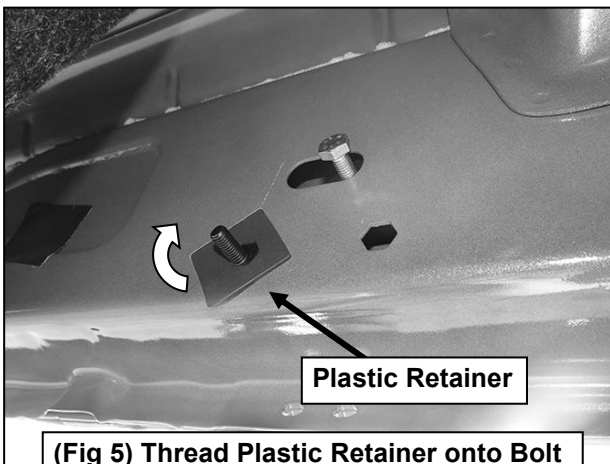

(Fig 5) Thread Plastic Retainer onto Bolt Plate to hold Bolt Plate in position.

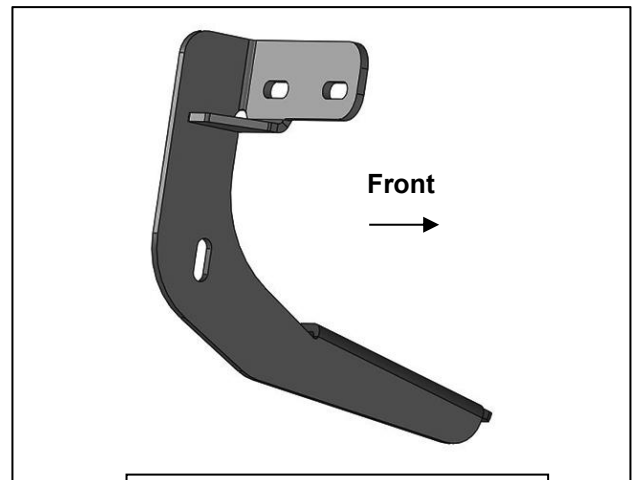

(Fig 6) Driver front Bracket

Driver Side Installation Pictured

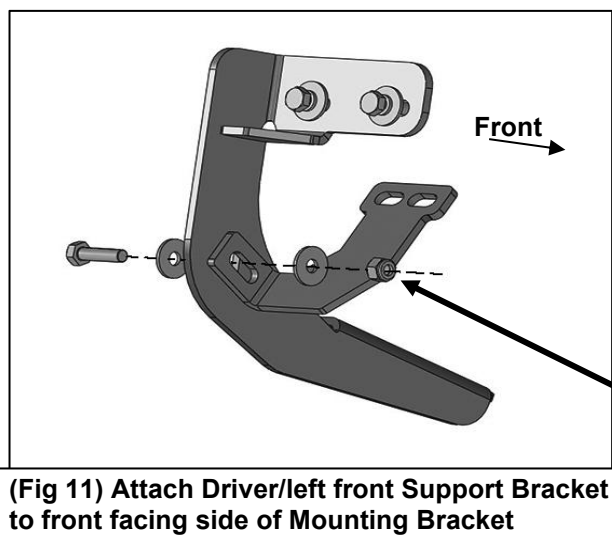
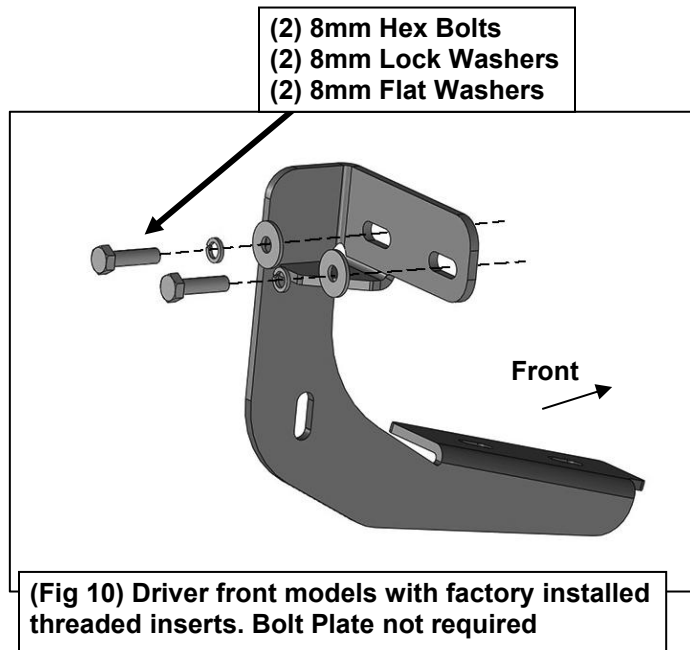
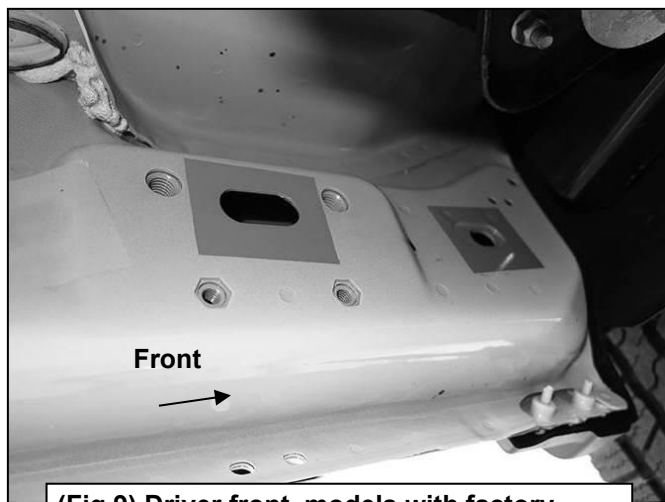
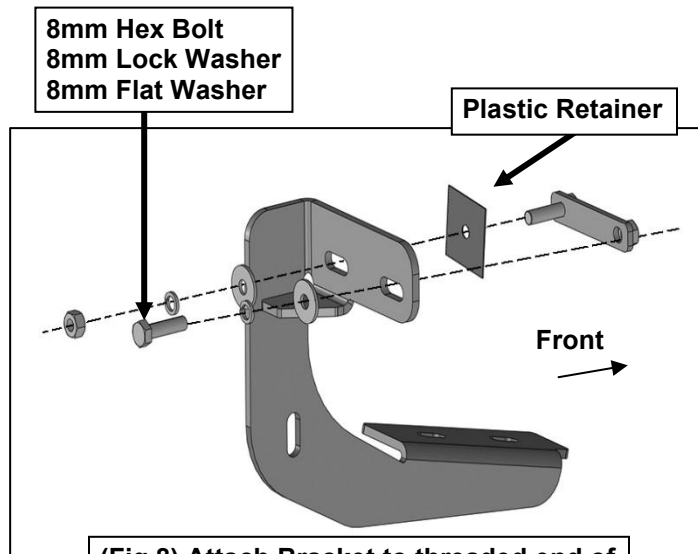
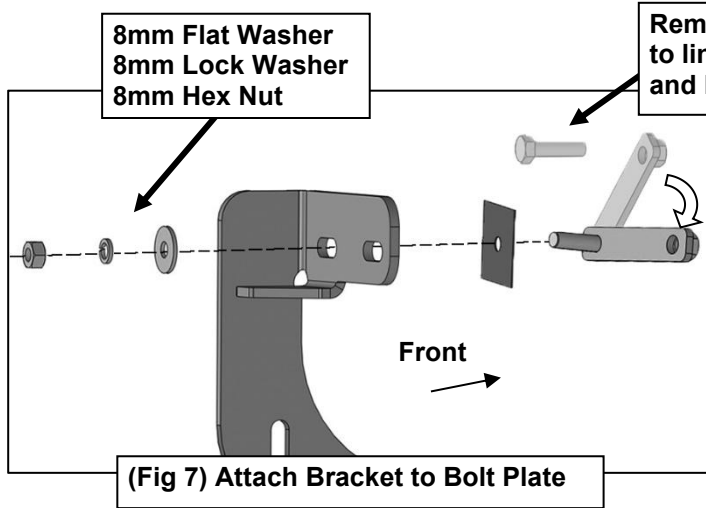

Driver Side Installation Pictured

- (2) 6mm Hex Bolts
- (4) 6mm Flat Washers
- (2) 6mm Nylon Lock Nuts

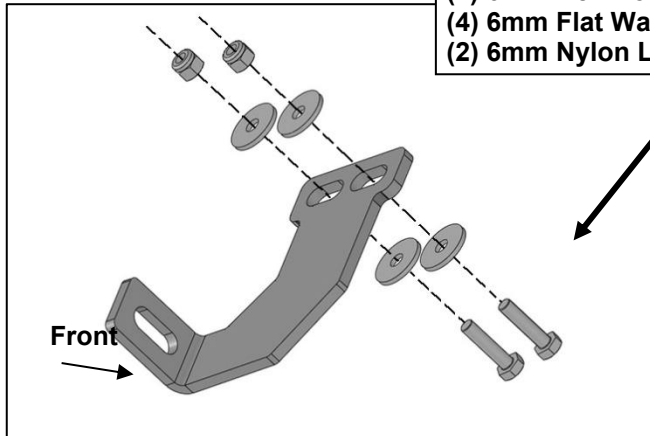

IMPORTANT: 2009-2012 models without holes in pinch weld will require drilling 1/4" holes through pinch weld to attach Support Brackets. Do complete installation of Running Board first and level Running Board before drilling holes for Support Brackets.

(Fig 12) Attach Support Bracket to back of pinch weld (models with factory holes in pinch weld only)

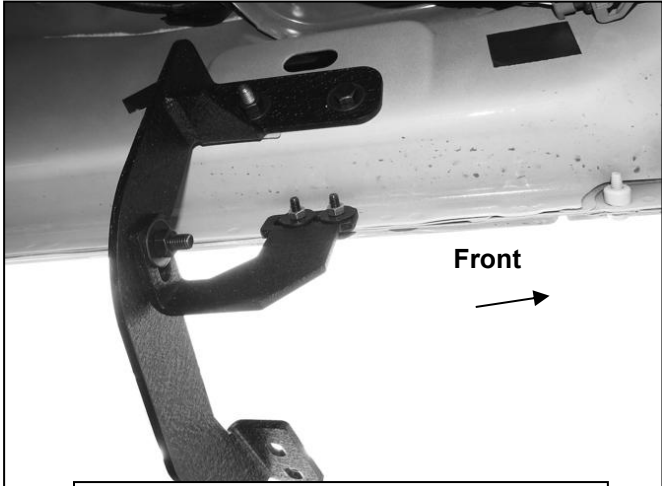

(Fig 13) Driver/left front Brackets attached to body panel and pinch weld

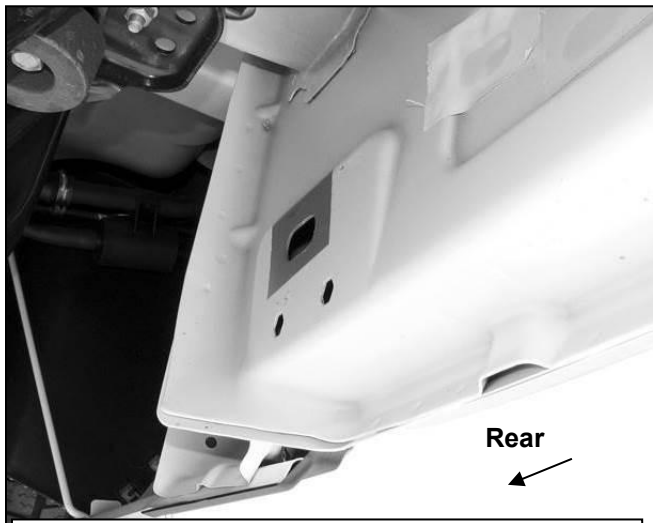

(Fig 14) Driver/left rear mounting location



(Fig 15) Driver/left Rear Brackets



(Fig 16) Driver/left rear Brackets attached to body panel and pinch weld

Driver Side Installation Pictured

8mm Double Bolt Plate

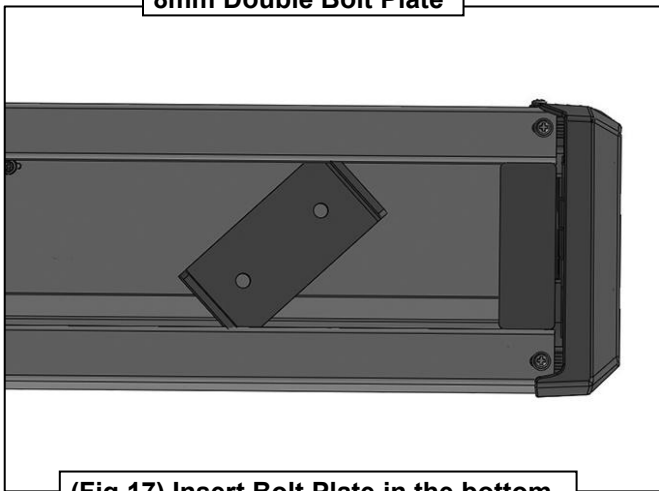

(Fig 17) Insert Bolt Plate in the bottom of the channel on the Running Board

(2) 8mm Flat Washers
(2) 8mm Nylon Lock Nuts

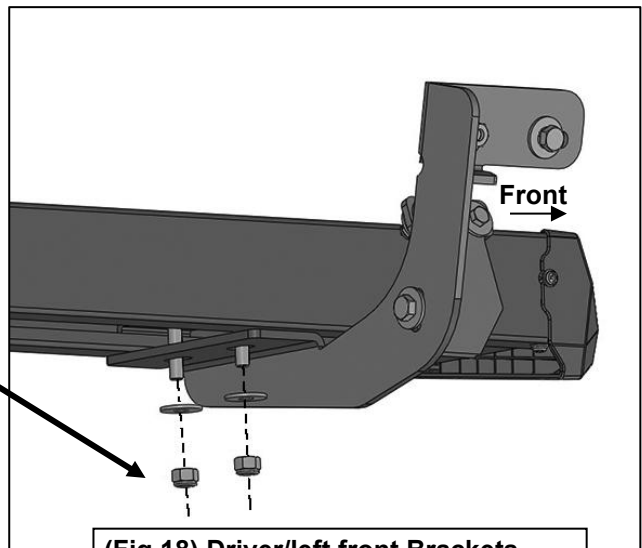

(Fig 18) Driver/left front Brackets attached to Running Board

Rear

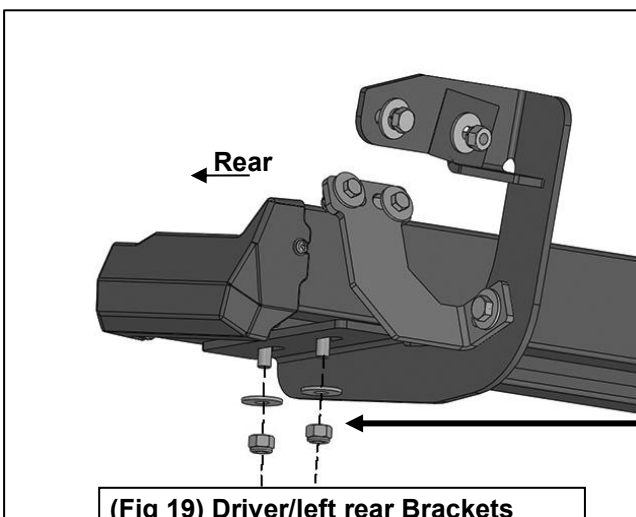

(2) 8mm Flat Washers
(2) 8mm Nylon Lock Nuts

(Fig 19) Driver/left rear Brackets attached to Running Board