

PARTS LIST:

1	Driver/Left DS4 Running Board	6	8mm Bolt Plates
1	Passenger/Right DS4 Running Board	18	8mm x 30mm Hex Bolts
1	Driver/Left Front Mounting Bracket	24	8mm x 24mm OD x 2mm Flat Washers
1	Passenger/Right Front Mounting Bracket	12	8mm Lock Washers
2	Driver/Left Center/Rear Mounting Brackets	6	8mm Hex Nuts
2	Passenger/Right Center/Rear Mounting Brackets	6	8mm Nylon Lock Nuts
3	Driver/Left Support Brackets	6	8mm Plastic Retainers
3	Passenger/Right Support Brackets	12	6mm x 25mm Hex Bolts
12	10mm x 30mm Hex Bolts	24	6mm x 22mm OD x 2mm Flat Washers
24	10mm x 20mm OD x 2mm Flat Washers	12	6mm Nylon Lock Nuts
12	10mm Nylon Lock Nuts		

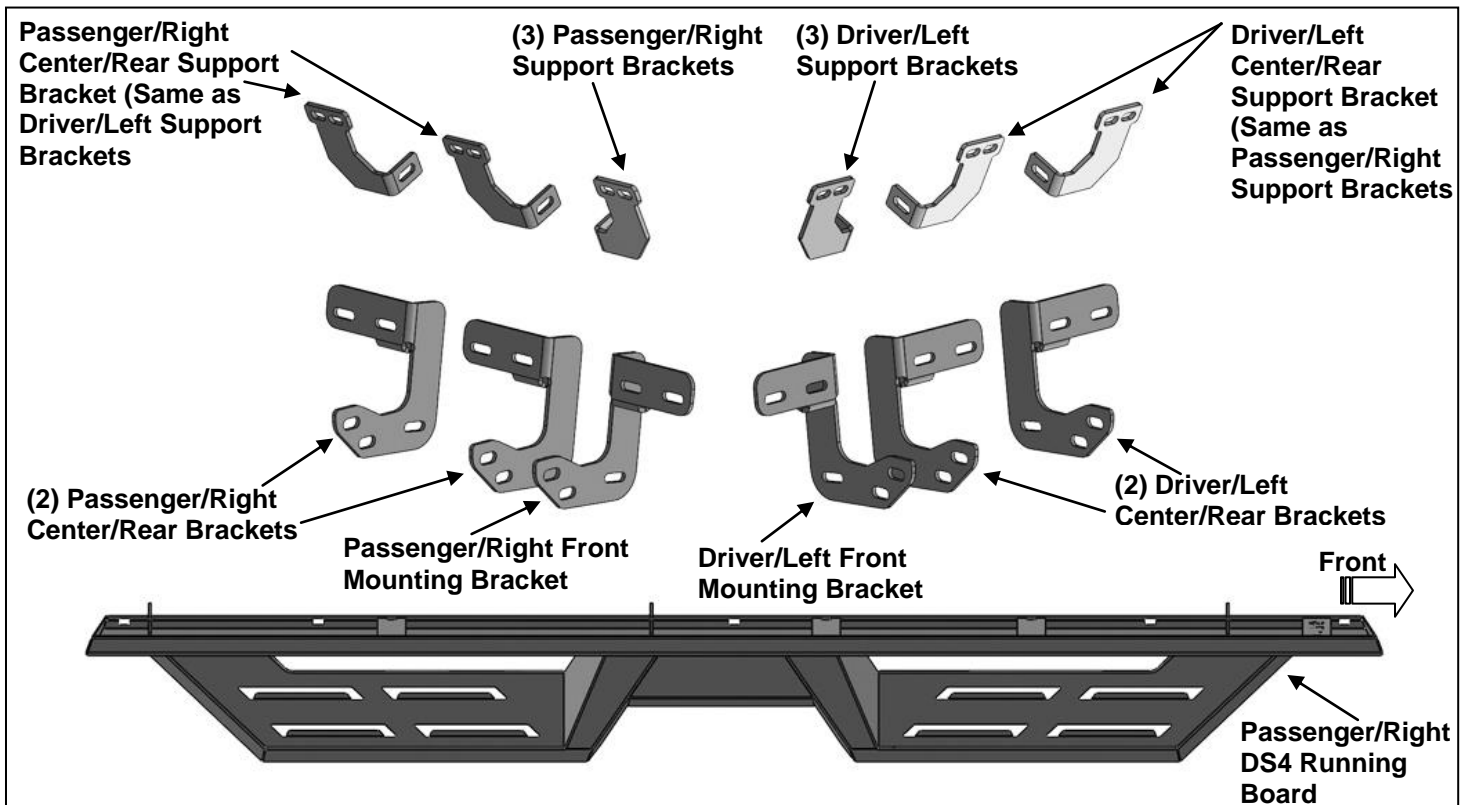

PROCEDURE: REMOVE CONTENTS FROM BOX. VERIFY ALL PARTS ARE PRESENT. READ INSTRUCTIONS CAREFULLY BEFORE STARTING INSTALLATION. DRILLING MAY BE REQUIRED.

- Starting at the passenger side-front of the vehicle, remove the sealing tape covering the factory holes in the side of the inner panel, **(Figure 1)**.
- Determine the correct procedure to attach the passenger side front Bracket for your model/year:

Models without factory threaded inserts in body panel:

- Select (1) 8mm Bolt/nut Plate, **(Figure 2)**. Partially thread an 8mm Hex Bolt onto the threaded end of the Nut Plate, **(Figure 3)**. Thread the Hex Bolt in until it is flush with the welded nut. Use the Hex Bolt as a handle and insert the Bolt and Nut Plate into the oval hole, **(Figure 4)**. Feed the threaded bolt on the Bolt Plate through one of the hex shaped factory holes.
- Thread (1) 8mm Plastic Retainer onto the threaded end and down tight against the body panel, **(Figure 5)**. **NOTE:** The Plastic Retainer is designed to keep the Bolt/Nut Plate from falling into the body panel and to aid in Bracket installation.
- Select (1) Passenger/right Bracket, **(Figure 6)**. Attach the Bracket to the threaded end of the Bolt Plate with (1) 8mm Flat Washer, (1) 8mm Lock washer and (1) 8mm Hex Nut, **(Figure 6)**. **IMPORTANT:** Passenger/right Front Bracket is the same as the Passenger/right Center and Driver/left Rear Brackets. Do not tighten hardware.

- d. Remove the 8mm Hex Bolt from the nut on the Bolt Plate from **Step 2a**. Rotate the Bolt on the Bolt Plate until the threaded nut lines up with the remaining hole in the Mounting Bracket and body panel, **(Figure 7)**. Attach the Bracket to the threaded Nut Plate with (1) 8mm x 30mm Hex Bolt, (1) 8mm Lock Washer and (1) 8mm Flat Washer, **(Figure 7)**. Do not tighten hardware.

Models with factory threaded inserts:

- a. Attach the Passenger/right Front Bracket to the threaded inserts with (2) 8mm x 30mm Hex Bolts, (2) 8mm Lock Washers and (2) 8mm Flat Washer, **(Figures 8 & 9)**. Do not tighten hardware.
3. Select (1) Passenger/Right Support Bracket. Attach the Bracket to the back of the pinch weld with (2) 6mm Hex Bolts, (4) 6mm Flat Washers and (2) 6mm Flange Nuts, **(Figure 10)**. Do not tighten hardware. Attach the Support Bracket to the Mounting Bracket with (1) 8mm Hex Bolt, (2) 8mm Flat Washers and (1) 8mm Nylon Lock Nut, **(Figure 11)**. **IMPORTANT:** 2009-12 models not equipped with factory holes will require drilling through the pinch weld to fully attach Bracket. Do not drill through pinch weld at this time, **(see Step 7)**.
4. Move along the side of the body panel to the center mounting location, **(Figure 12)**. Repeat **Steps 1—3** to install (1) Passenger/Right Mounting Bracket and (1) Passenger/Right Support Bracket to the center mounting location.
5. Move to the rear location, **(Figure 13)**. Repeat **Steps 1—3** to attach (1) Driver/Left Mounting Bracket and (1) Driver/Left Support Bracket to the Passenger/Right rear mounting location.
6. Select the Passenger/Right DS4 Running Board. Attach the Running Board to the rear faces on the Mounting Brackets with (6) 10mm Hex Bolts, (12) 10mm Flat Washers and (6) 10mm Nylon Lock Nuts, **(Figure 14)**. Do not tighten hardware.
7. Properly level and adjust the Running Board and fully tighten all hardware.
2009-12 models requiring drilling through pinch trim:
 - a. Level the Running Board to the vehicle. Make sure all (3) Brackets are tight against the bottom of the body panel and tighten all mounting hardware.
 - b. Mark the location of the slots onto the pinch weld.
 - c. Drill (2) 1/4" holes through the pinch weld for each Bracket. **IMPORTANT:** Do not drill too close to the bottom edge of the pinch weld. Drill the holes in the center of the marked slots.
 - d. Repeat **Step 3** to attach the Brackets to the drilled holes in the pinch weld. Check for level then fully tighten all hardware.
8. Repeat **Steps 1—7** to attach the Driver/Left DS4 Running Board.
9. Do periodic inspections to the installation to make sure that all hardware is secure and tight.

To protect your investment, Do not use any type of polish or wax that may contain abrasives that could damage the finish. Mild soap may be used to clean the Running Boards.

Passenger Side Installation Pictured

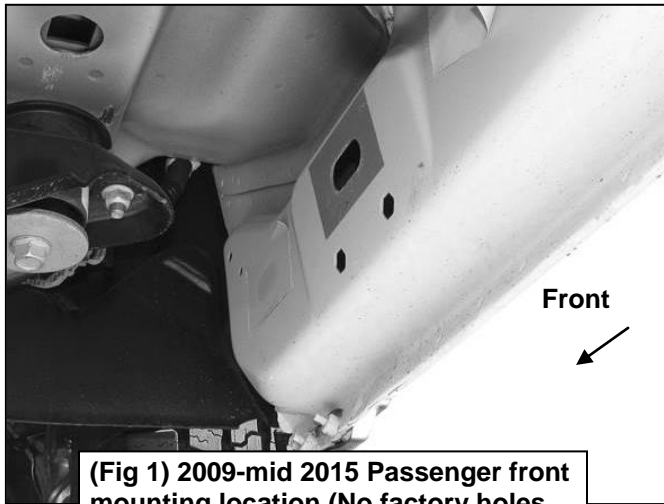

(Fig 1) 2009-mid 2015 Passenger front mounting location (No factory holes in pinch weld 2009-2012 models)

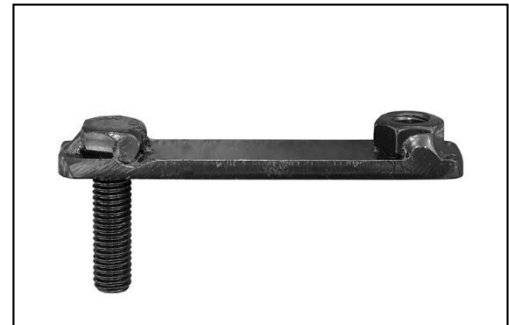

(Fig 2) 8mm Bolt-8mm Nut Plate, NOTE: 8mm Bolt-Nut Plate is not required on models with threaded inserts

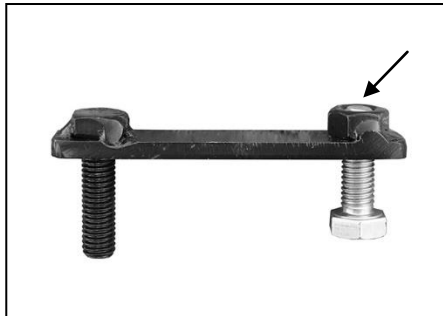

(Fig 3) Thread (1) 8mm Hex Bolt into the nut on the plate. Stop when bolt reaches end of nut as pictured

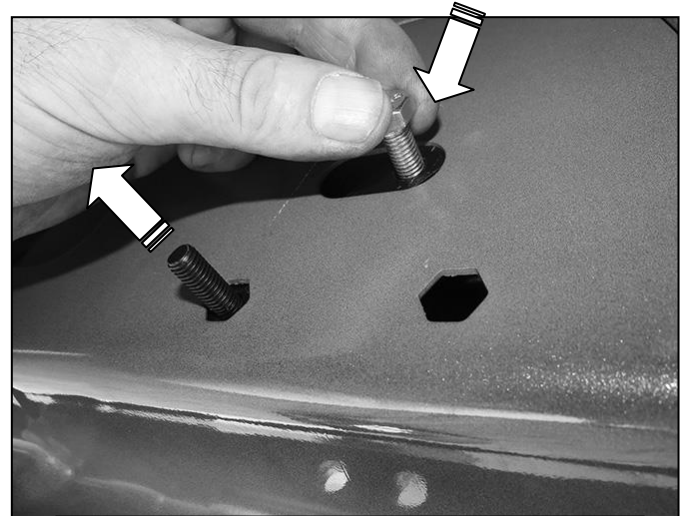

(Fig 4) Use the loose Hex Bolt as a handle. Insert the Bolt Plate into the oval hole and feed the threaded end out either factory hex shaped hole. IMPORTANT: Do not let go of the hex bolt until after Plastic Retainer has been threaded onto bolt (Fig 5)

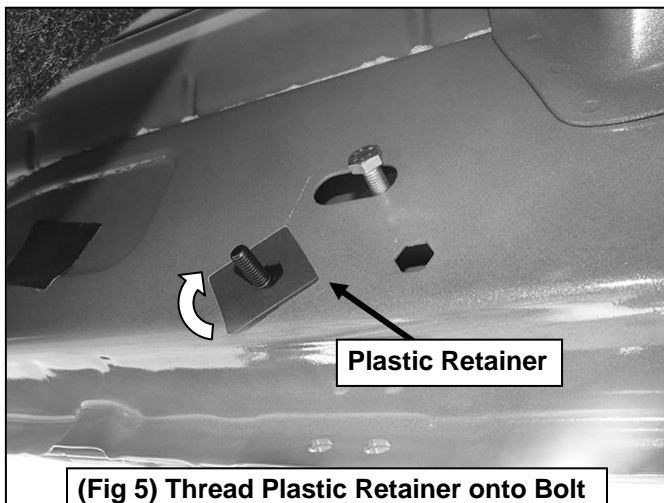

(Fig 5) Thread Plastic Retainer onto Bolt Plate to hold Bolt Plate in position.

Passenger Side Installation Pictured

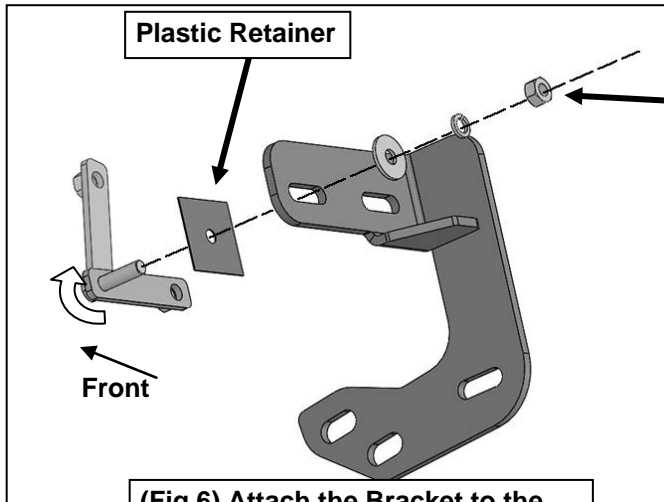

(Fig 6) Attach the Bracket to the threaded bolt on the Bolt/Nut Plate

- 8mm Flat Washer
- 8mm Lock Washer
- 8mm Hex Nut

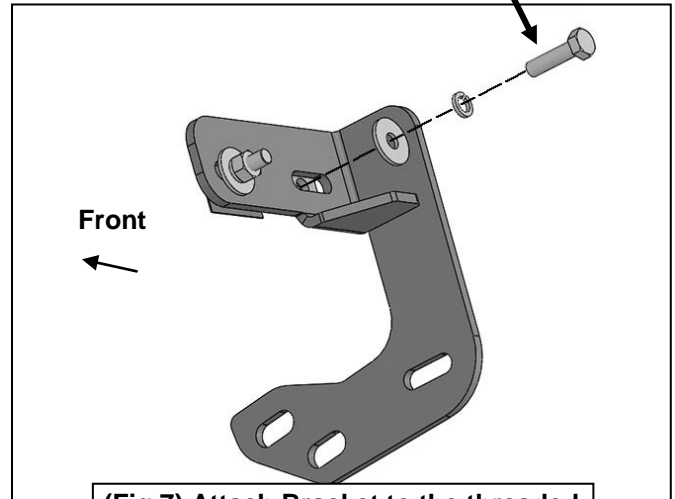

(Fig 7) Attach Bracket to the threaded hole in the Bolt/Nut Plate

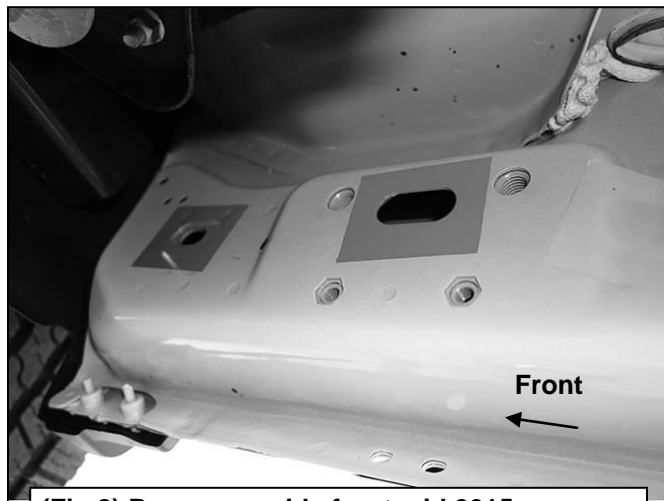

(Fig 8) Passenger side front mid 2015-on, models with factory installed threaded inserts

- (2) 8mm Hex Bolts
- (2) 8mm Lock Washers
- (2) 8mm Flat Washers

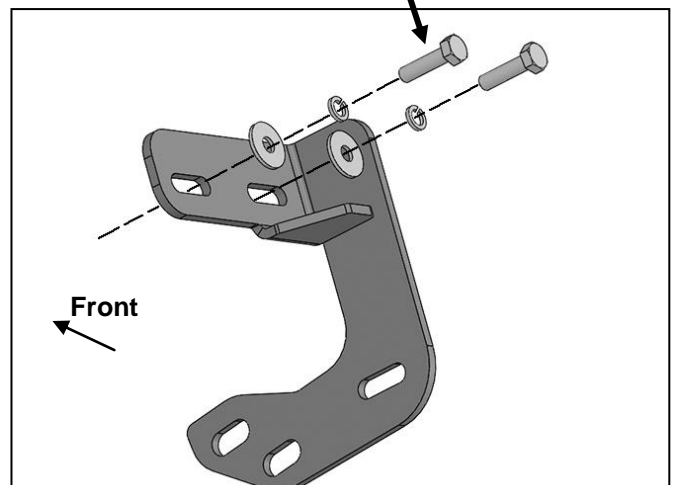

(Fig 9) Passenger/Right Front Mounting Bracket illustrated for models with threaded inserts

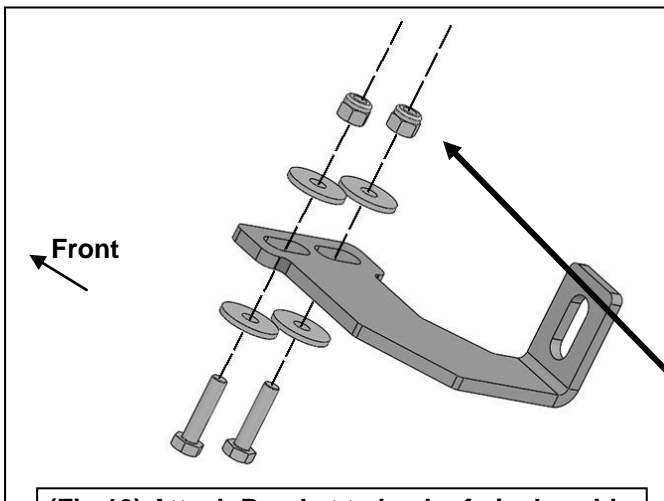

(Fig 10) Attach Bracket to back of pinch weld (models with factory holes in pinch weld only)

- (2) 6mm Hex Bolts
- (4) 6mm Flat Washers
- (2) 6mm Flange Nuts

Passenger Side Installation Pictured

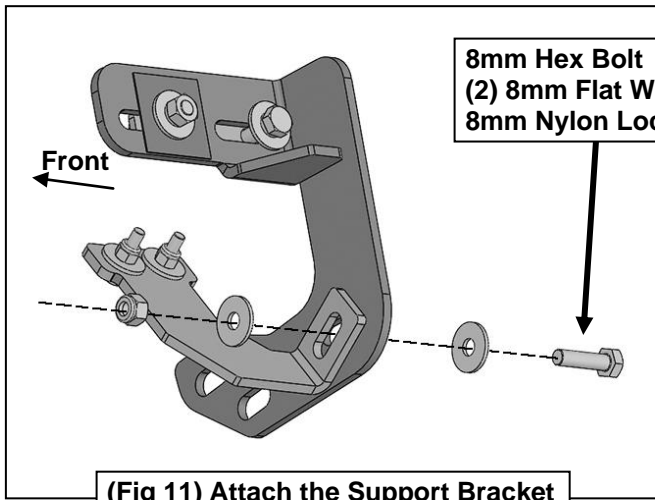

(Fig 11) Attach the Support Bracket to the Front Mounting Bracket

IMPORTANT: 2009-2012 models without holes in pinch weld will require drilling 1/4" holes through pinch weld to attach bracket. Do complete installation of sidebars first, level sidebar before drilling holes for bracket.

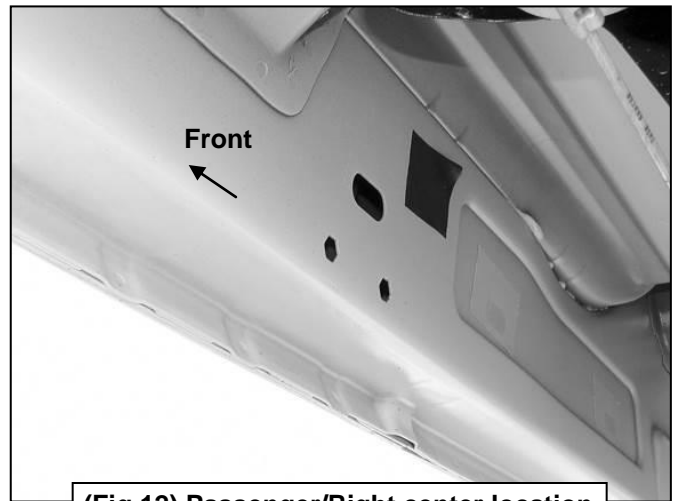

(Fig 12) Passenger/Right center location

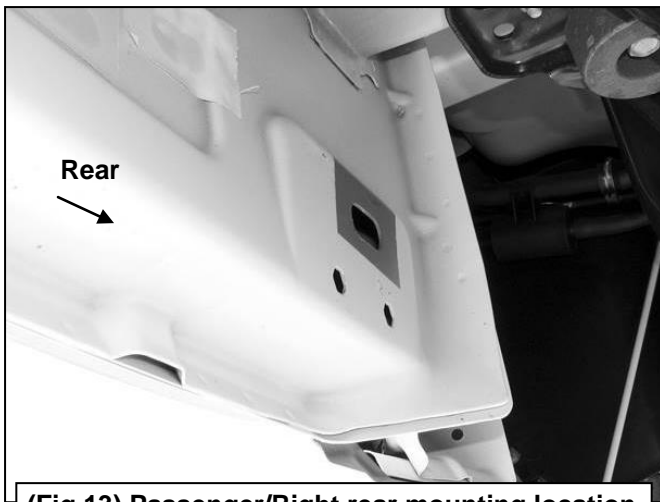

(Fig 13) Passenger/Right rear mounting location

- (2) 10mm Hex Bolts
- (4) 10mm Flat Washers
- (2) 10mm Nylon Lock Nuts

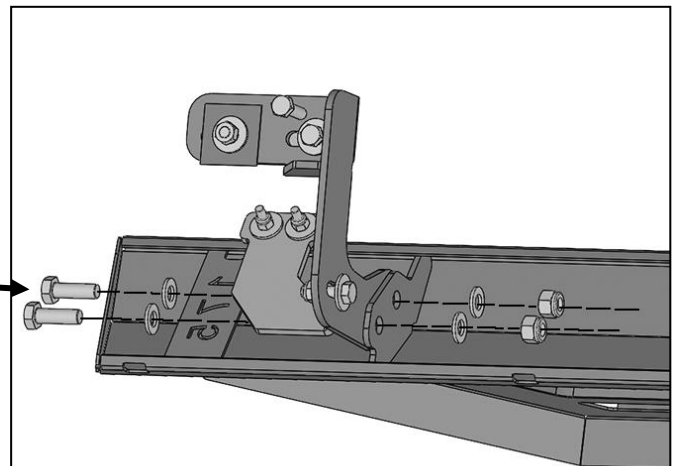

(Fig 14) Attach the Passenger/Right DS4 Running Board to the rear faces on the Mounting Brackets