

PARTS LIST:

1	Driver/Left S6 Running Board	8	8mm x 35mm Double Bolt Plates
1	Passenger/Right S6 Running Board	16	8mm x 30mm Hex Bolts
2	Driver/Left Front/Rear Mounting Brackets	16	8-1.25mm Nylon Lock Nuts
2	Passenger/Right Front/Rear Mounting Brackets	16	8mm Lock Washers
2	Driver/Left Center Mounting Brackets	32	8mm x 24mm OD x 2mm Flat Washers
2	Passenger/Right Center Mounting Brackets		

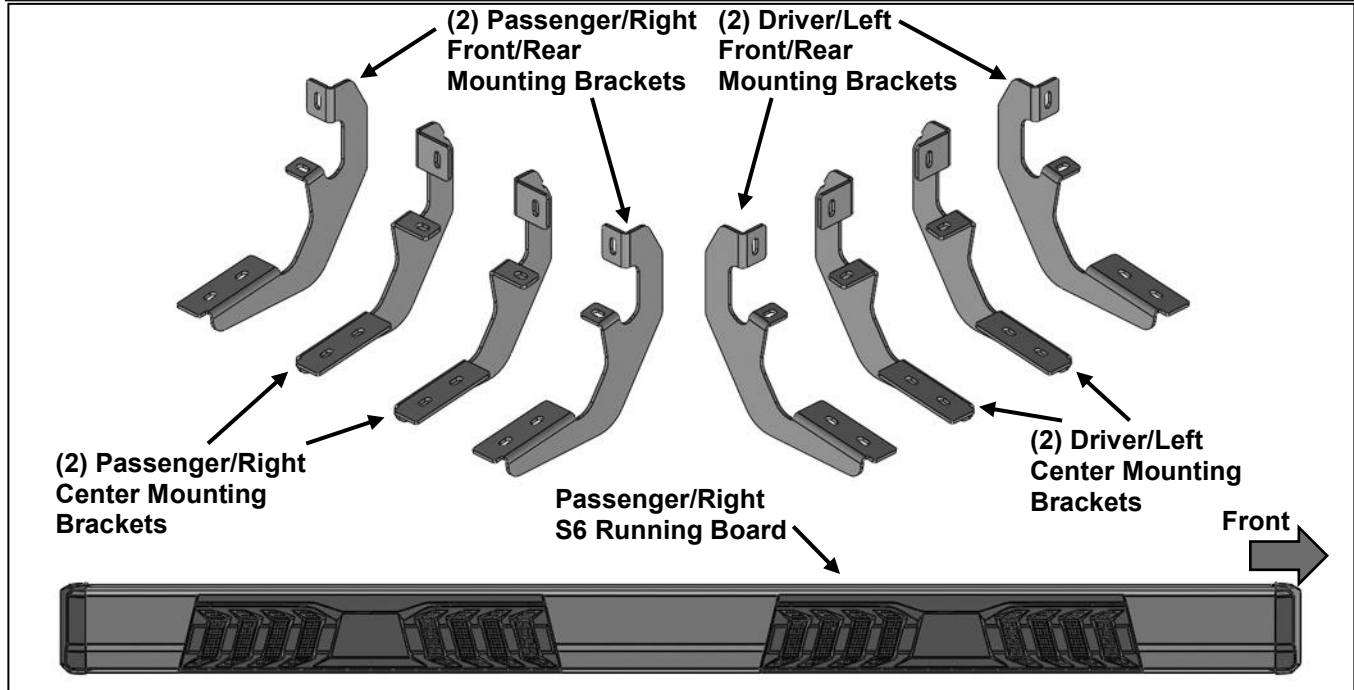

PROCEDURE:

- 1. REMOVE CONTENTS FROM BOX. VERIFY ALL PARTS ARE PRESENT. READ INSTRUCTIONS CAREFULLY. USE ILLUSTRATION TO IDENTIFY BRACKETS AND SIDEBARS.**
- Starting on the Passenger/Right front of the vehicle, remove the plastic plugs covering the threaded holes in the body panel, if equipped, **(Figure 1)**. Select (1) Mounting Bracket. Attach the Bracket to the vehicle with (2) 8mm Hex Bolts, (2) 8mm Lock Washers and (2) 8mm Flat Washers, **(Figure 2)**. Do not tighten hardware. **NOTE:** The Mounting Brackets look similar but are unique. The Front/Rear Mounting Brackets have a shorter rear-facing mounting tab and the Center Mounting Brackets have a notch and longer forward-facing mounting tabs, **(Figure 3)**.
- Repeat **Step 2** to install (3) Mounting Brackets to the 2nd, 3rd and rear mounting locations, **(Figures 4—6)**. Do not tighten hardware.
- Unwrap the Passenger/Right S6 Running Board. Select (3) 8mm Double Bolt Plates, **(Figure 7)**. Insert the Bolt Plates into the channel in the bottom of the Running Board.
- Place the Running Board on top of the (3) Mounting Brackets. Lift the Running Board up and guide the studs down through the Brackets. **IMPORTANT:** Do not slide the Running Board on the Brackets, (front to back or rotate), or the finish on the Running Board may be damaged.
- Attach the Running Board to the Brackets with (6) 8mm Flat Washers and (6) 8mm Nylon Lock Nuts, **(Figure 8)**. Do not tighten hardware.
- Level and adjust the S6 Running Board and tighten all hardware.
- Repeat **Steps 2—7** to attach the Driver/Left S6 Running Board.
- Do periodic inspections to the installation to make sure that all hardware is secure and tight.

To protect your investment, Do not use any type of polish or wax that may contain abrasives that could damage the finish. Mild soap may be used to clean the Running Boards.

Passenger/Right Side Installation Pictured

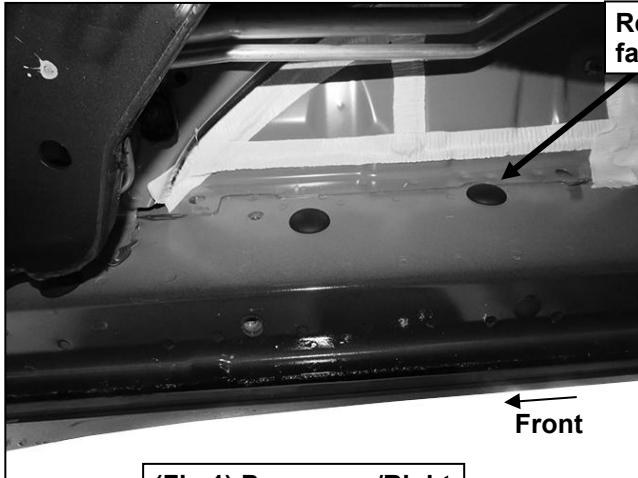

Remove plastic plugs or factory hex bolts (if equipped)

(Fig 1) Passenger/Right front mounting location

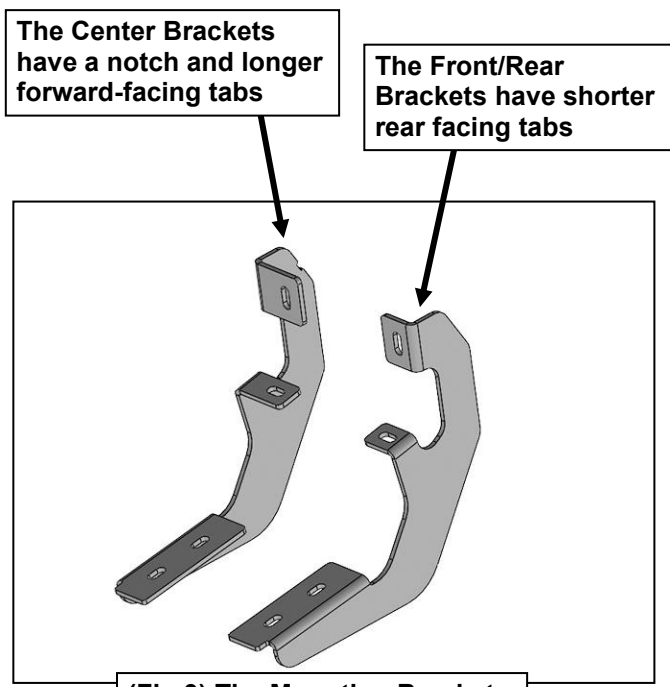

The Center Brackets have a notch and longer forward-facing tabs

The Front/Rear Brackets have shorter rear facing tabs

(Fig 3) The Mounting Brackets are similar but are unique

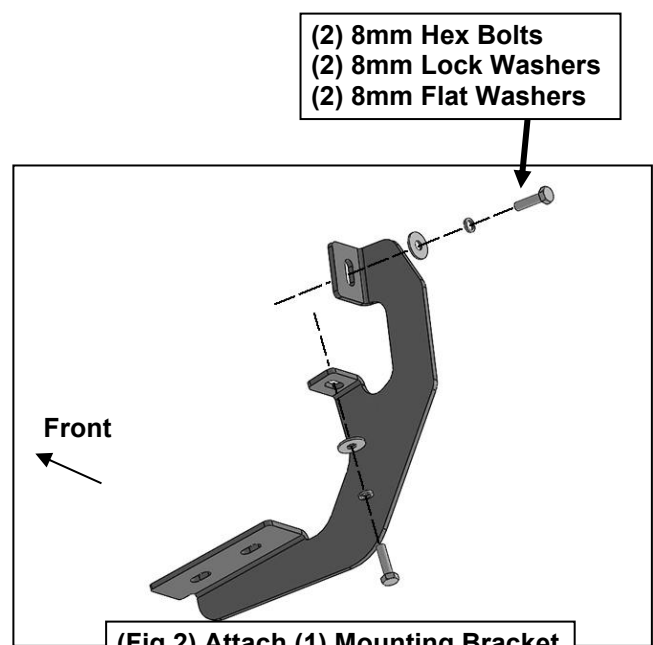

(2) 8mm Hex Bolts
(2) 8mm Lock Washers
(2) 8mm Flat Washers

(Fig 2) Attach (1) Mounting Bracket to the front mounting location

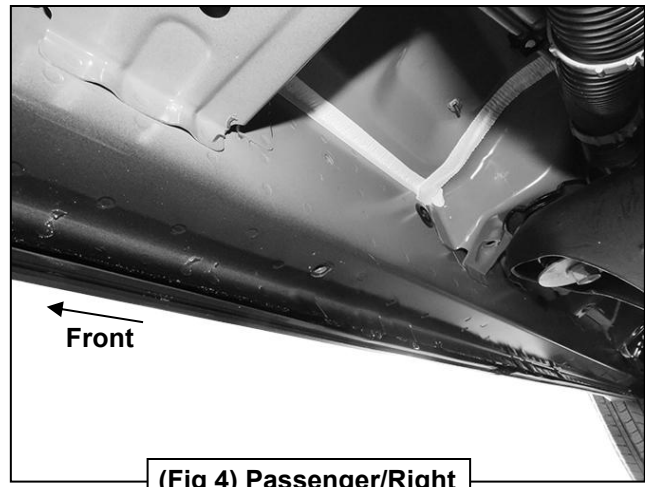

(Fig 4) Passenger/Right 2nd mounting location

Passenger/Right Side Installation Pictured

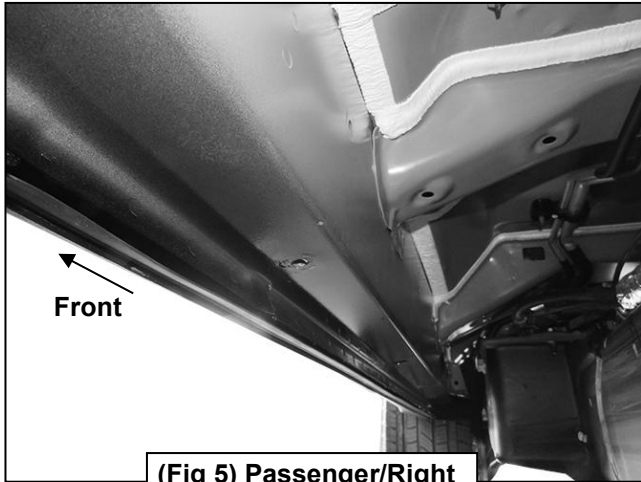

(Fig 5) Passenger/Right
3rd mounting location

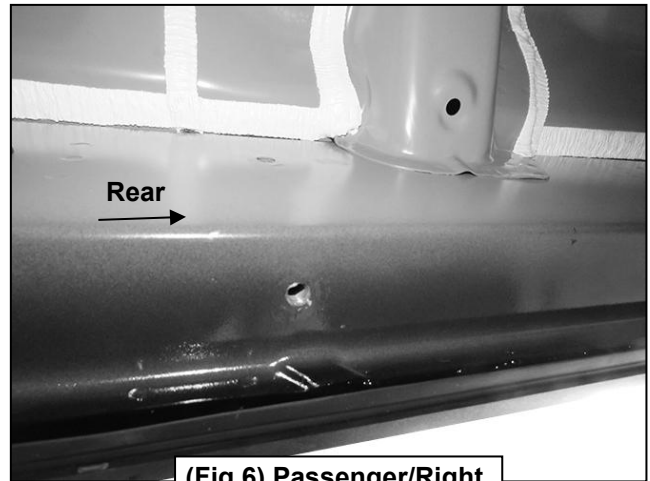

(Fig 6) Passenger/Right
rear mounting location

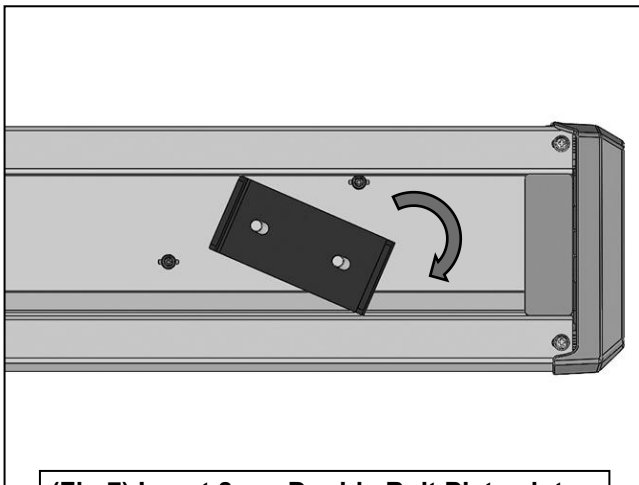

(Fig 7) Insert 8mm Double Bolt Plates into
tracks on the bottom of the Running Board

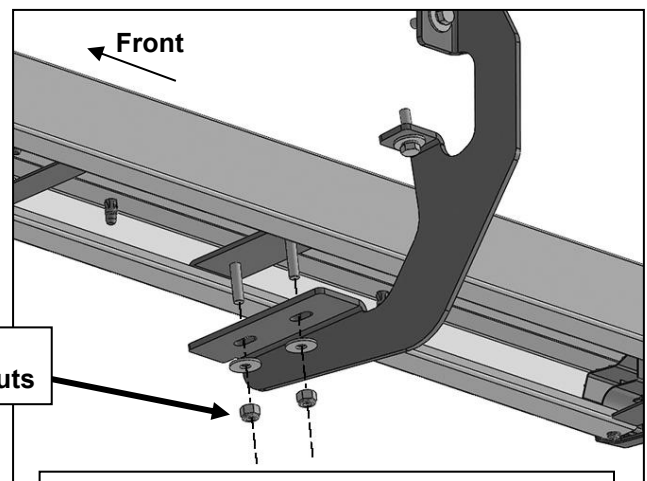

(2) 8mm Flat Washers
(2) 8mm Nylon Lock Nuts

(Fig 8) Attach the Passenger/Right Running
Board to the Mounting Brackets