

**PARTS LIST:**

1	Driver/Left Tube	8	8mm x 25mm Triangle Double Bolt Plates
1	Passenger/Right Tube	1	8mm x 35mm Single Bolt Plate
4	Drop Steps	1	8mm x 40mm Hex Bolt
4	Driver/Left Mounting Brackets	16	8mm x 25mm Hex Bolts
3	Passenger/Right Rear Mounting Brackets	1	8mm x 28mm OD x 3mm Flat Washer
1	Passenger/Right Front Upper Bracket	17	8mm x 24mm OD x 2mm Flat Washers
1	Passenger/ Right Front Lower Bracket	16	8mm x 22mm OD x 2mm Flat Washers
16	10mm x 30mm Hex Bolts	17	8mm Lock Washers
32	10mm x 20mm OD x 2mm Flat Washers	17	8mm Nylon Lock Nuts
16	10mm Nylon Lock Nuts	15	8mm Clip Nuts

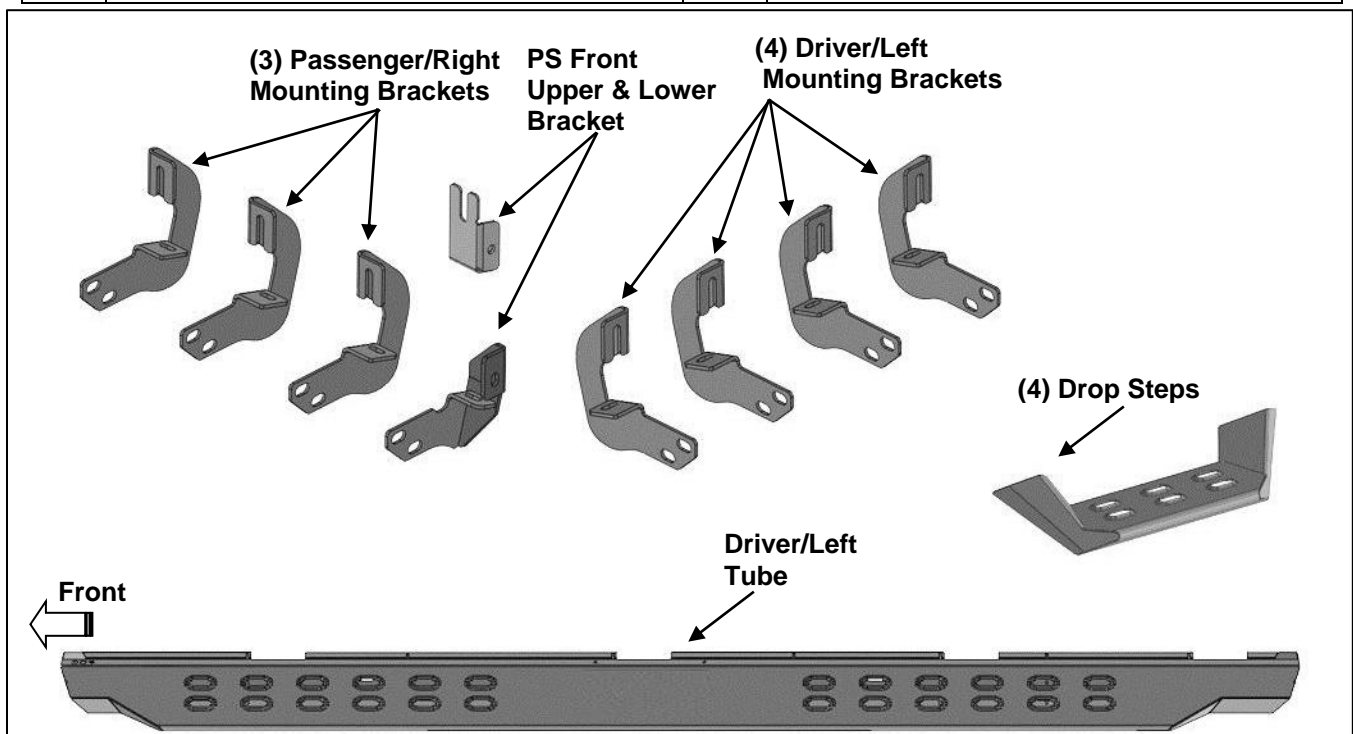

**PROCEDURE: REMOVE CONTENTS FROM BOX. VERIFY ALL PARTS ARE PRESENT. READ INSTRUCTIONS CAREFULLY BEFORE STARTING INSTALLATION. ON MODELS WITH DEF TANK, SELECT A FLAT, LEVEL AREA FOR INSTALLATION. MAY REQUIRE CUTTING.**

1. Start the installation under the Driver/Left side of the vehicle. Locate the 4 tabs along the bottom edge of the body, (pinch weld). Mounting will use 1st, 2nd, 4th and 5th tab locations, **(Figure 1)**. Directly above each tab is a top mounting location on the side of the body panel. Hold a Bracket up in place to help determine the mounting holes to use along the body.
2. Determine the correct procedure for your model year and each Bracket location.

**Bottom mounting location on the edge of the pinch weld.**

**Flat tab on pinch weld with factory installed weld nut:**

Thread hex bolt into weld nut from the backside-down to clear paint from threads, **(Figure 2)**.

**Flat tab on pinch weld with hole:**

Select (1) 8mm Clip Nut. Slide the Clip Nut over the tab with the nut facing up behind the tab, **(Figure 3)**. Line up threaded nut with hole in the tab.

**Locate top mounting location on the back side of the rocker panel.**

**Models with factory installed threaded insert in rocker panel:**

Thread 8mm Hex Bolt into threaded insert to clear paint as required.

**Large and small hole in side of rocker panel:**

Remove the rubber plug from the larger hole. Select (1) 8mm Clip Nut. Slide the Clip Nut into the larger hole. Line up the threaded nut with the smaller hole, **(Figure 3)**.

3. Select (1) Driver/Left Mounting Bracket. Bolt the Mounting Bracket to the Clip Nuts and/or the factory threaded holes with (2) 8mm Hex Bolts, (2) 8mm Lock Washers and (2) 8mm Flat Washers, **(Figure 4)**. Do not tighten hardware.
4. Repeat **Steps 1—3** to attach the remaining (3) Driver/Left Mounting Brackets, **(Figures 5 & 6)**.
5. Select the Driver/Left Tube. Insert (2) 8mm Triangle Double Bolt Plates into the front (2) sets of (2) holes, **(Figure 7)**. Attach (1) Drop Step to the (2) Double Bolt Plates with (4) 8mm x 22mm Flat Washers and (4) 8mm Nylon Lock Nuts, **(Figure 8)**. Do not tighten hardware.
6. With assistance, line up the mounting tabs in the Driver/Left Tube to the rear faces of the Mounting Brackets. Secure the Tube to the Mounting Brackets with (8) 10mm Hex Bolts, (16) 10mm x 20mm Flat Washers and (8) 10mm Nylon Lock Nuts, **(Figure 9)**. Do not tighten hardware.
7. Level and adjust the Overland Step, then tighten all hardware.
8. Move to the Passenger/Right side of the vehicle. On the Passenger/Right side, determine if the vehicle is equipped with a plastic diesel exhaust fluid (DEF) tank, **(Figures 10 & 11)**.

**Models without DEF tank, skip to Step 9.**

**Models with DEF tank:** The tank sits close to the side of the body. With specialized tools, the passenger front upper and lower Bracket can be installed but room is very limited.

**Determine model year of vehicle before proceeding.**

**Up to 2016 models:**

It may be easier to drop the tank down to access the inner side of the body panel for upper bracket installation. Tank will not need to be removed, only dropped down for access to mounting location.

**IMPORTANT:** If tank is full, it will be very heavy and assistance is highly recommended to avoid injury or damage to the vehicle or the tank. It is recommended that installation is performed when the DEF tank is low on fluid before dropping the tank.

- a. On models with plastic lower tray under the tank, remove the (3) hex bolts attaching the tray to the frame, **(Figure 10)**, and remove the tray.
- b. Release the tank filler hose. Release the plug for the sending unit on the top of the tank.
- c. Support the tank with a floor jack. Place a smooth flat surface, (wooden block for example), between the floor jack and the tank to avoid damaging the plastic tank. Do not push up on the tank; only support the weight of the tank with the jack.
- d. Remove the (2) bolts securing the tank straps to the vehicle, **(Figure 11)**. Tilt the straps to release from the brackets. Slowly lower the tank until the top of the tank is almost visible. Use blocks or stands to support the tank while installing the front Upper and Lower Brackets.
- e. Proceed to **Step 9**.

**2017 models and on:**

- a. Remove the (4) hex bolts attaching plastic cover to DEF tank, **(Figure 12A)** and remove plastic cover, **(Figure 12B)**. **NOTE:** On 2017-on 2500/3500 models, only remove plastic cover from DEF tank. **Do not lower DEF tank** and proceed to **Step 9**.
9. Locate the first tab on the edge of the pinch weld. Select the Upper Bracket, **(Figure 13)**. Attach the Upper Bracket with (1) 8mm x 25mm Hex Bolt, (1) 8mm Lock Washer and (1) 8mm Flat Washer, **(Figure 14)**. Do not tighten hardware at this time.
10. Line up the hole in the bottom of the Upper Bracket with the hole in the tab on the pinch weld.
  - a. **Models with a weld-nut:** Slide the Bracket over the weld-nut. Attach the Lower Bracket to the bottom of the body and weld-nut with (1) 8mm x 40mm Hex Bolt, (2) 8mm Flat Washers and (1) 8mm Nylon Lock Nut, **(Figure 17)**. Do not tighten hardware.
  - b. **Models with flat tab and hole:** Insert the 8mm Bolt Plate down through the hole in the Upper Bracket and tab. Attach the Lower Bracket to the bottom of the body and Bolt Plate with (1) 8mm Flat Washer and (1) 8mm Nylon Lock Nut, **(Figures 15 & 16)**. Do not tighten hardware.

11. Secure the front of the Lower Bracket to the Upper Bracket with (1) 8mm x 25mm Hex Bolt, (1) 8mm Lock washer and (1) 8mm x 24mm Flat Washer, (**Figure 18**). Do not tighten hardware.
12. Repeat **Steps 1—4** to attach the (2) remaining Passenger/Right Mounting Brackets.
  - a. **2017-on DEF tank models:** Locate the 2nd tab bracket location along the bottom edge of the body, (pinch weld). Hold the DEF cover in place and mark the location onto the cover, (**Figures 19A & 19B**). Use a sharp knife or hacksaw blade to carefully cut a slot in the plastic cover to clear the 2nd Bracket. Remove as little plastic as possible.
13. Repeat **Steps 5—7** to attach the Passenger/Right Overland Slider.
14. Once the Overland Slider has been installed and all hardware fully tightened, reinstall the DEF tank and cover, if equipped, as described in **Step 8**.
15. Do periodic inspections to the installation to make sure that all hardware is secure and tight.

**To protect your investment,** Do not use any type of polish or wax that may contain abrasives that could damage the finish. Mild soap may be used also to clean the Overland Sliders.

### Driver/Left Side Installation Pictured

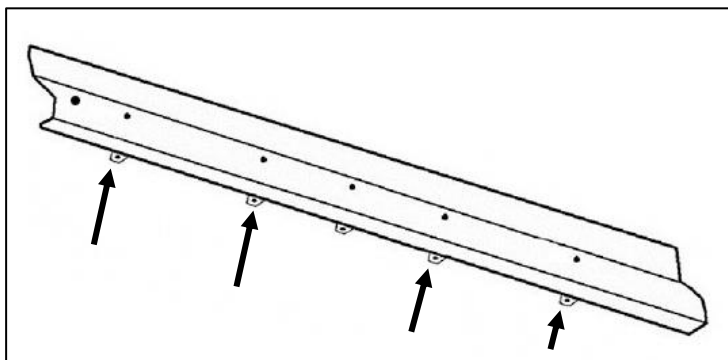

(Fig 1) Driver/Left (4) mounting locations

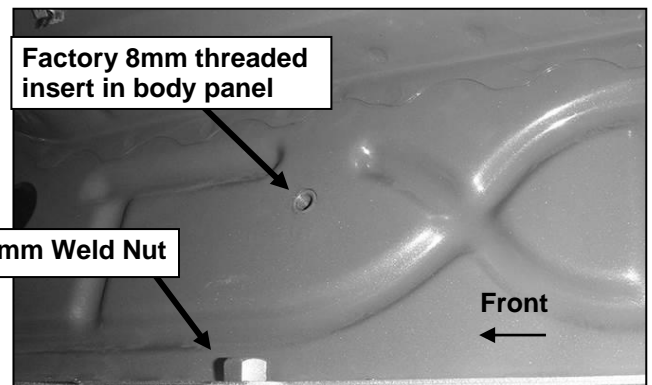

(Fig 2) Passenger/Right Front mounting location

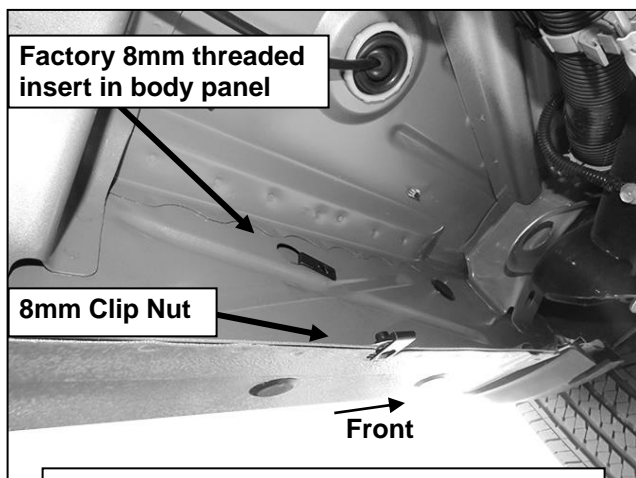

(Fig 3) Driver/Left Front mounting location

- (2) 8mm x 25mm Hex Bolts
- (2) 8mm Lock Washers
- (2) 8mm Flat Washers
- (2) 8mm Clip Nuts

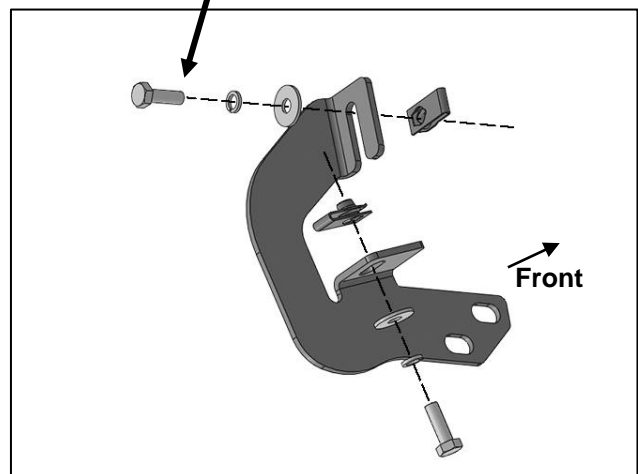

(Fig 4) Driver/Left Front bracket installed

**Driver/Left Side Installation Pictured**

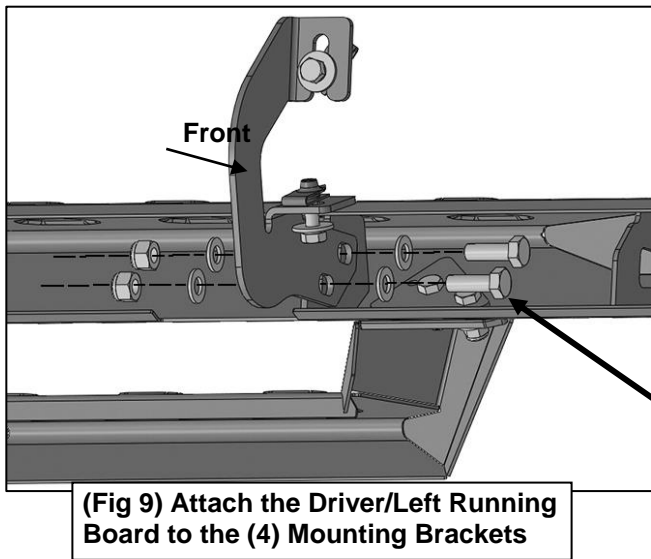
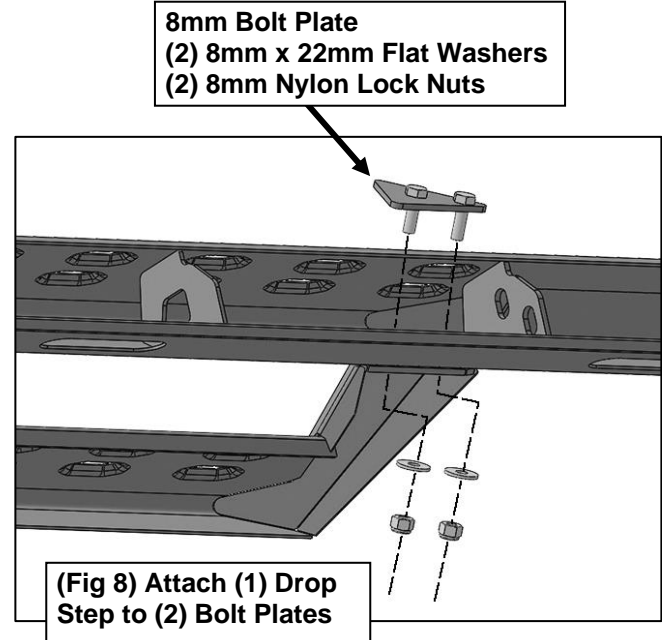
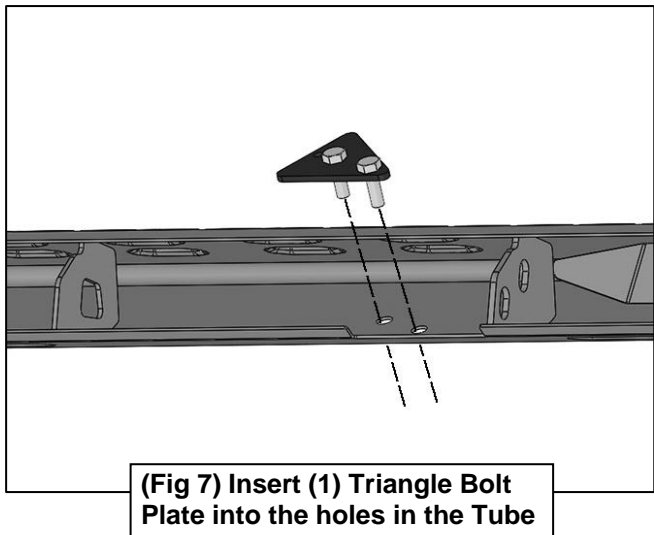
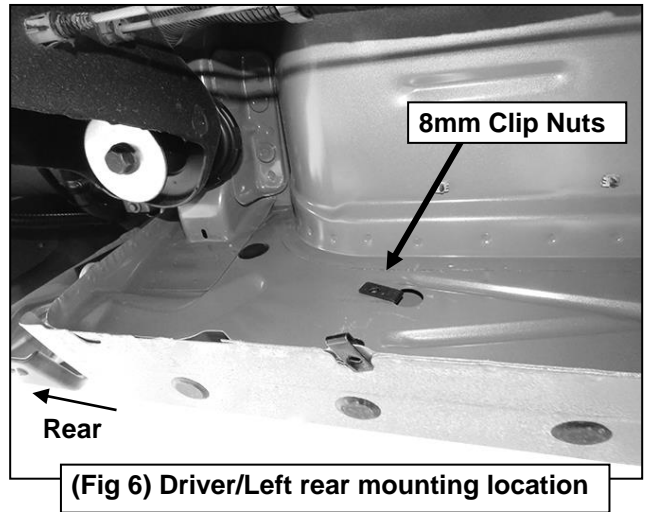
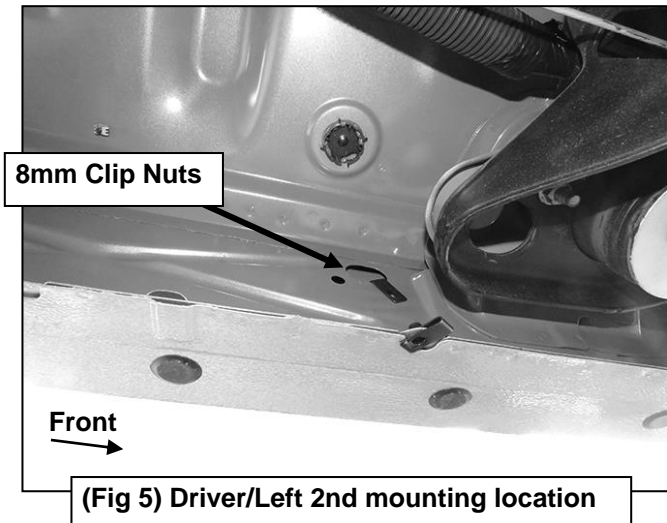

- (2) 10mm Hex Bolts**
- (4) 10mm Flat Washers**
- (2) 10mm Nylon Lock Nuts**

**Passenger/Right Side Installation Pictured**

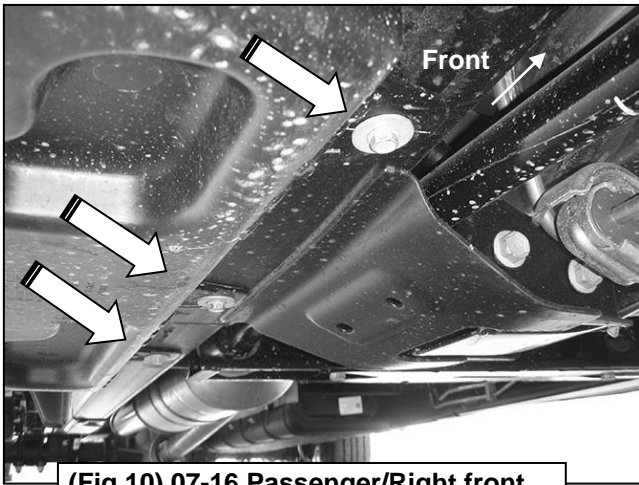

**(Fig 10) 07-16 Passenger/Right front pictured with DEF tank cover. Remove (3) hex bolts to remove cover**

**Remove (2) factory bolts to remove tank straps**

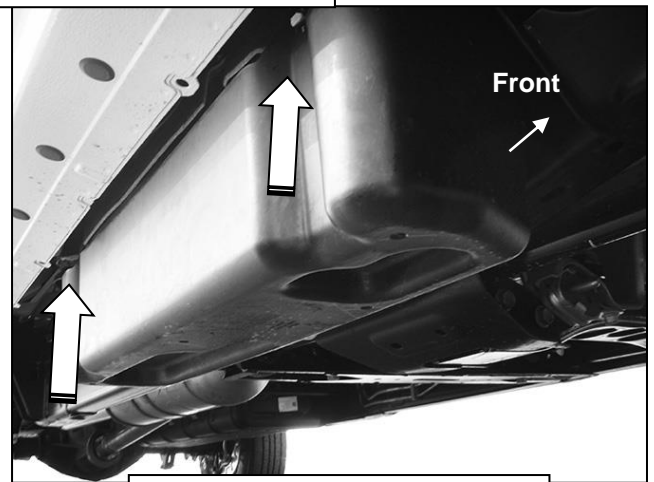

**(Fig 11) 07-16 Passenger/Right DEF tank and cover**

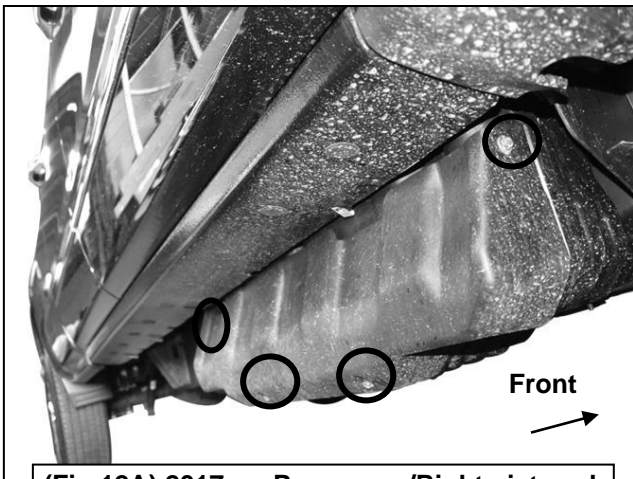

**(Fig 12A) 2017-on Passenger/Right pictured with DEF plastic tank cover. Remove (4) hex bolts to remove plastic cover**



**(Fig 12B) 2017-on Passenger/Right DEF cover**

**Passenger/Right side Installation Pictured**

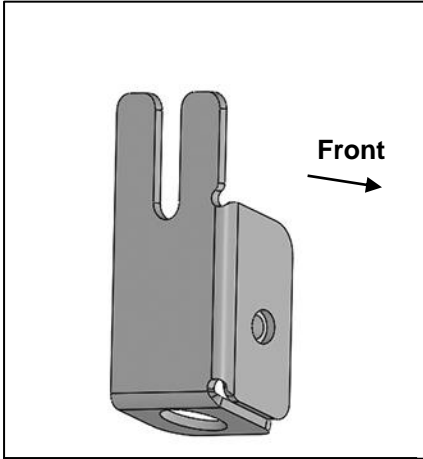

**(Fig 13) Passenger/Right Front Upper Bracket (all models)**

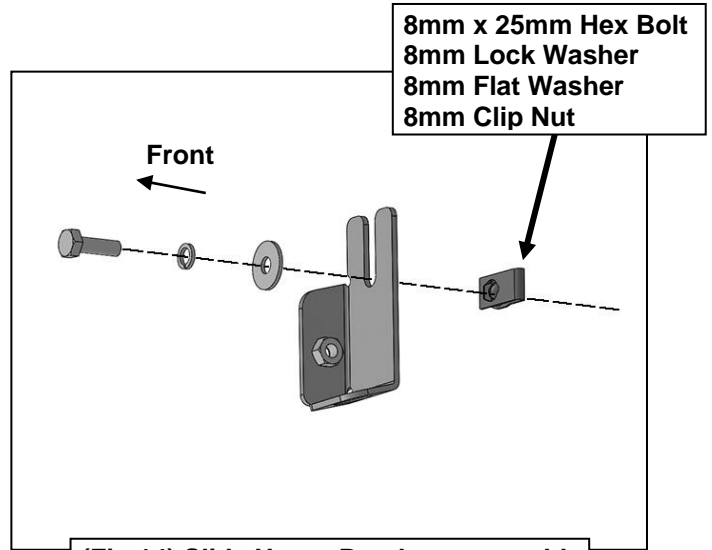

**(Fig 14) Slide Upper Bracket over weld nut if equipped-also see Figure 2**



**(Fig 15) 8mm x 35mm Bolt Plate**

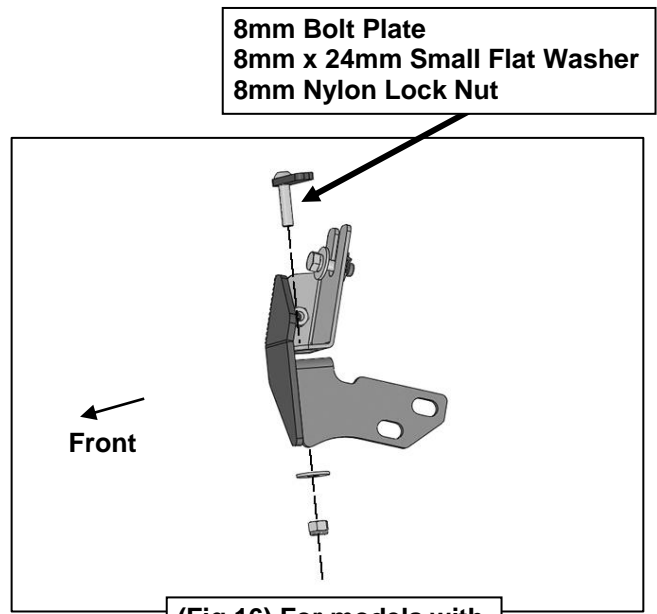

**(Fig 16) For models with a hole in the pinch weld**

**Passenger/Right side Installation Pictured**

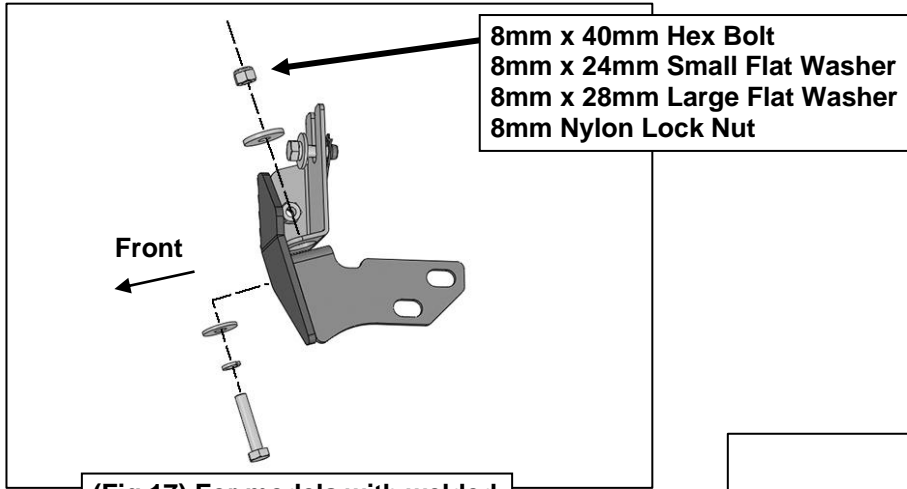

**(Fig 17) For models with welded nut in the pinch weld**

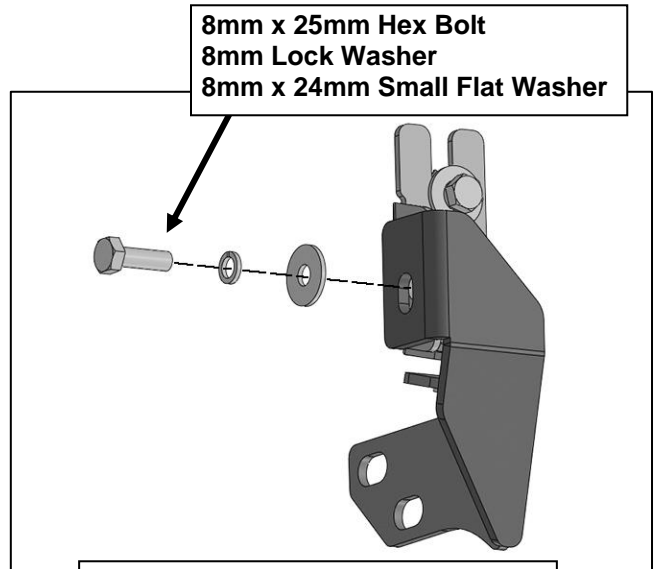

**(Fig 18) Secure the side of the Lower Bracket to the Upper Bracket**



**(Fig 19A) 2017-on DEF tank Mark for cut is approximately 70mm x 10mm**



**(Fig 19B) 2017-on Passenger DEF cut for example only**