

INSTALLATION INSTRUCTIONS

POWER STEPS

**21-23 FORD F-150, 22-24 SUPERDUTY SUPER CAB & SUPERCREW CAB
(INCL. 2022 LARIAT, KING RANCH, LIMITED, AND PLATINUM TRIMS ONLY
FOR SUPDERDUTY) SYNC 4 MODELS ONLY
PART# HW-PB-FW187**

INSTALLATION INSTRUCTIONS

Mechanical PARTS LIST:

Qty	Item Description	Qty	Item Description
2	Running Boards (85in)	12	M8 Nylon Lock Nuts
1	Driver/Left Front Bracket Assembly	12	Flat Washers 8mm x 24mm x 2mm
1	Passenger/Right Front Bracket Assembly	8	M6 Carriage Bolts
1	Driver/Left Rear Bracket Assembly	12	Plastic Insulator
1	Passenger/Right Rear Bracket Assembly	8	M6 Flange Nuts
1	Electronic Materials Package	15	Zip Ties
1	Rubber Sleeve		

Electronic Materials Package PARTS LIST:

Qty	Item Description	Qty	Item Description
1	Main Harness	1	ECU
2	LED Y-Harness	4	LED lights
2	Wire Taps		

A

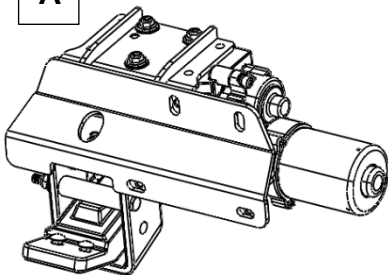

Driver Front
Bracket Assembly

B

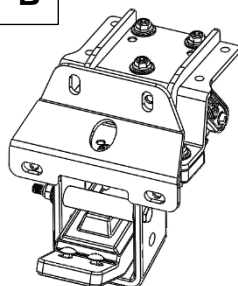

Driver Rear
Bracket Assembly

C

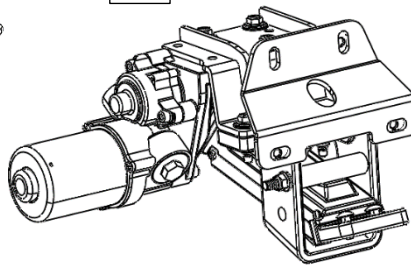

Passenger Front
Bracket Assembly

D

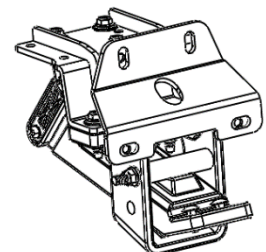

Passenger Rear
Bracket Assembly

E

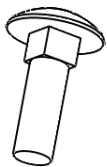

M6 Carriage
Bolt

F

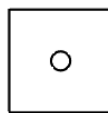

Plastic
Insulator

G



M6 Flange Nut

H



Flat Washer

I

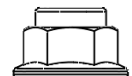

M8 Nylon
Lock Nut

***NOTE:** Driver and
Passenger Rear Bracket
Assemblies are the same.

J

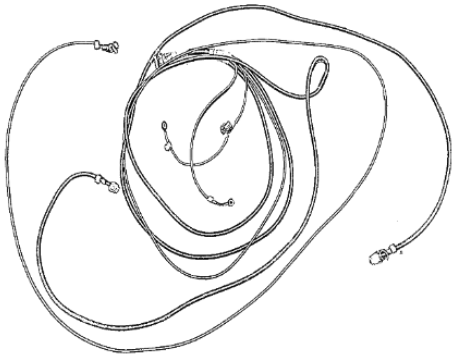

Main Harness

K

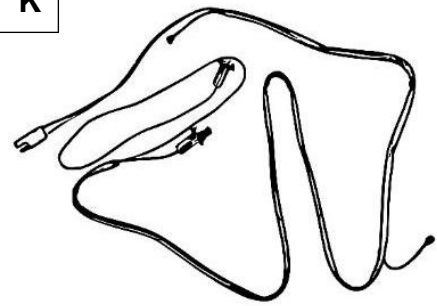

LED Y-Harness

L



Wire Taps

M



ECU

N

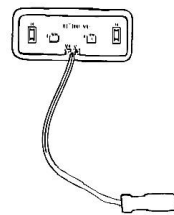

LED Lights

TOOLS REQUIRED



Ratchet



8mm
10mm
13mm
Socket



Extensions



Wrench

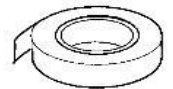

Electrical Tape

1

Locate Driver Side front mounting points on the rocker panel under the front door. Apply a plastic insulator (F) to each stud before mounting the front bracket.

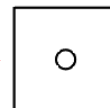
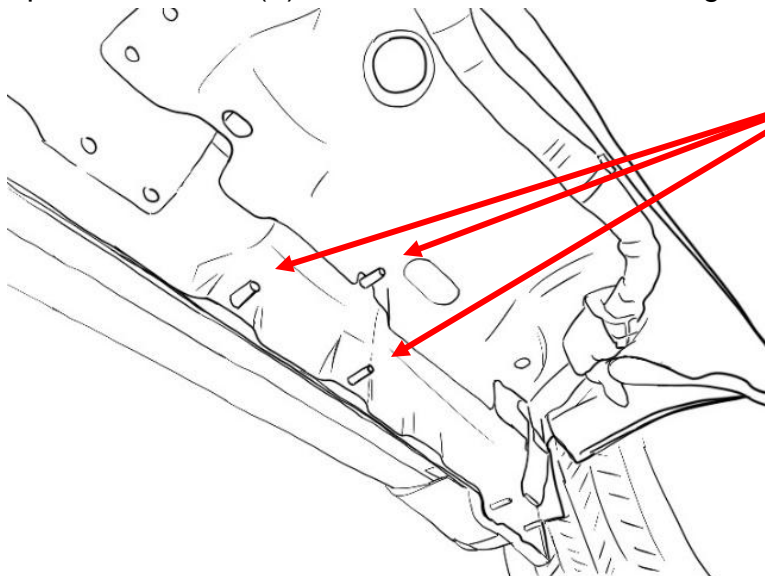

Plastic Insulator

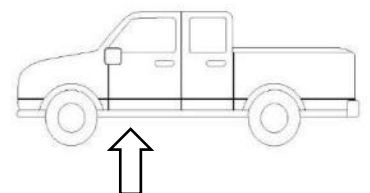

On SuperDuty vehicles, the rocker panel studs may have an OE nut already in place. Remove the nut, and then apply the plastic insulators (F) to the stud before mounting the brackets.

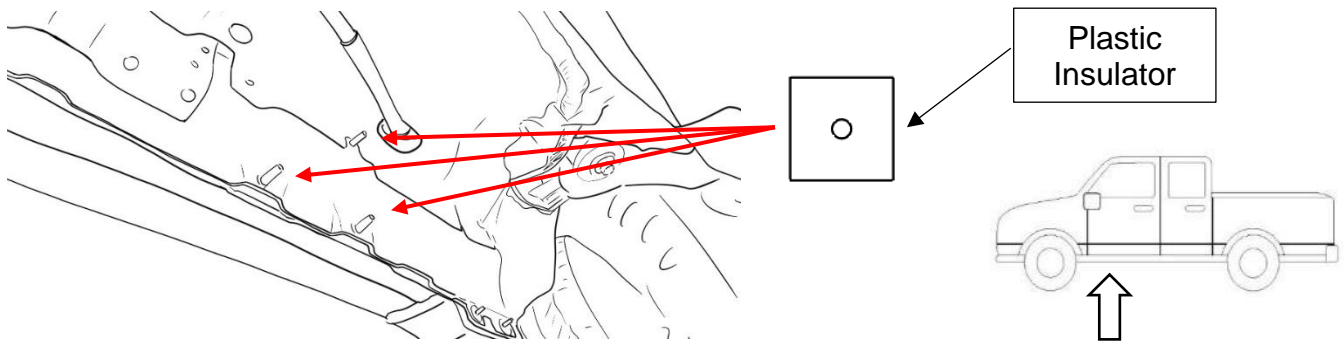

2

Next, line up front mounting bracket slots to the studs and place Driver Side/Left Front Bracket Assembly (A) onto rocker panel. Then fasten Nylon Lock Nuts (I) and washers (H). Do not tighten all the way yet.

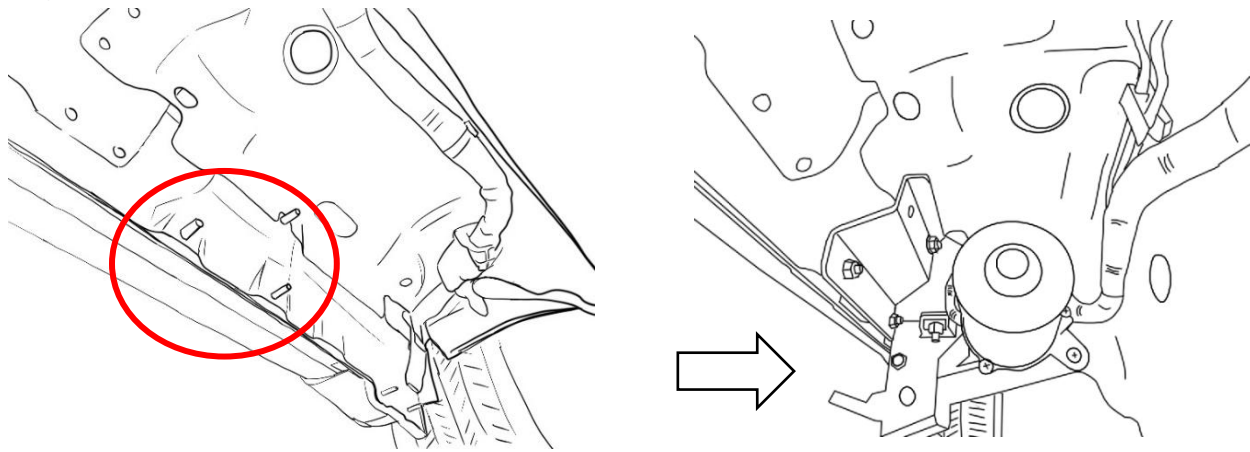

3

Locate rear mounting points. Apply a plastic insulator (F) to each stud before mounting the Driver Side Rear Bracket Assembly (B). Next, line up rear mounting bracket slots to the studs and place Driver Side/Left Rear Bracket Assembly (B) onto rocker panel.

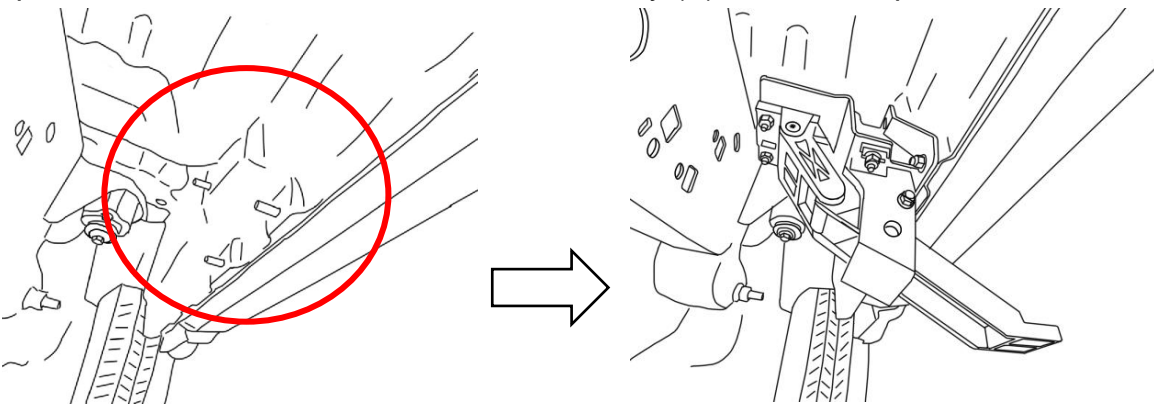

Then fasten Nylon Lock Nuts (I) and washers (H). Do not tighten all the way yet. For vehicles with e-brake cables on the Driver Side, take the rubber sleeve in the kit and slide over the brake line, just behind the bracket assembly, to protect the line from wear. Attach sleeve to line using RTV silicone sealant.

4

Repeat steps 1 – 3 for the Passenger Side.

- 5** Start from the engine compartment by opening the front hood of the vehicle. Locate the Battery and its terminals (positive/negative). Remove the 25A fuse from the fuse box that comes with the main harness (J).

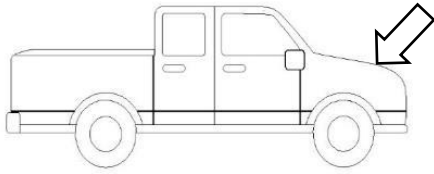

***WARNING:** Keeping the fuse connected to the fuse box may result in electrical sparks and risk of shorting when working with the battery.

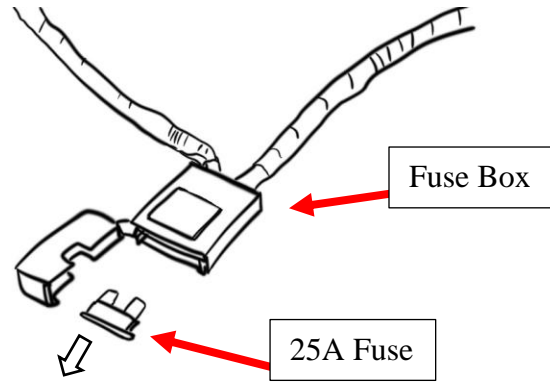

- 6** Connect the positive power lead on the main harness (J) to the positive battery terminal. Connect the negative lead to the negative battery terminal.

Make sure both power leads are fully secured.

Connect the ECU (M) to the main harness.

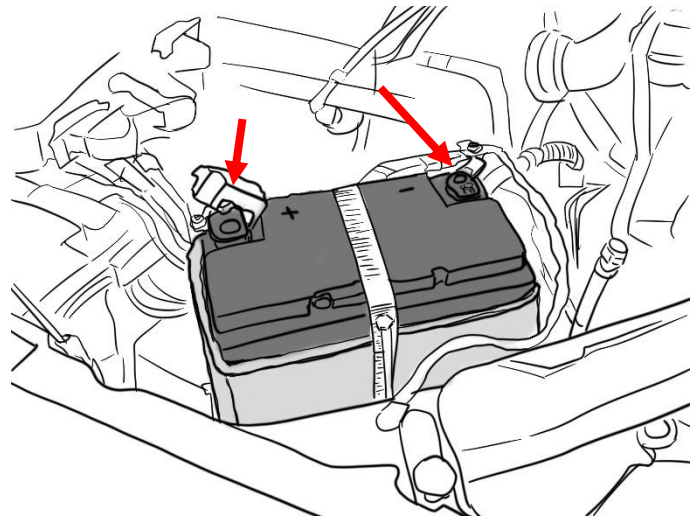

- 7** Route the main harness (J) around the battery, up along the rear of the engine compartment, and down the Driver-side wheel well. Route the shorter leg of the harness down the Passenger-side wheel well. **Be sure to avoid contact with any moving or hot engine components.** Attach and secure the main harness (J) with supplied cable ties.

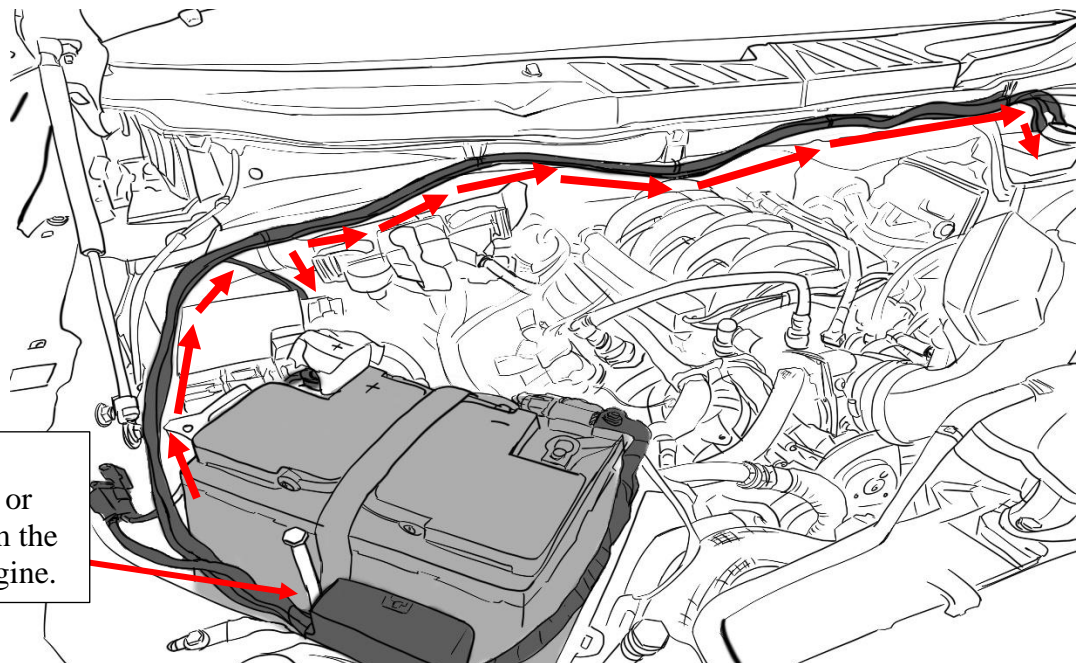

ECU (M) should be secured near battery or any space away from the direct heat of the engine.

8

On the underside of the driver side, locate and remove the floor grommet in the floor panel behind the front wheel well. The grommet will be close to the front linkage arm. Poke a hole through the grommet and thread the two signal wires through and up into the vehicle cabin.

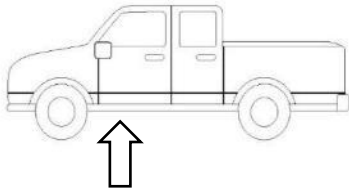

Carefully put wiring through rubber floor plug

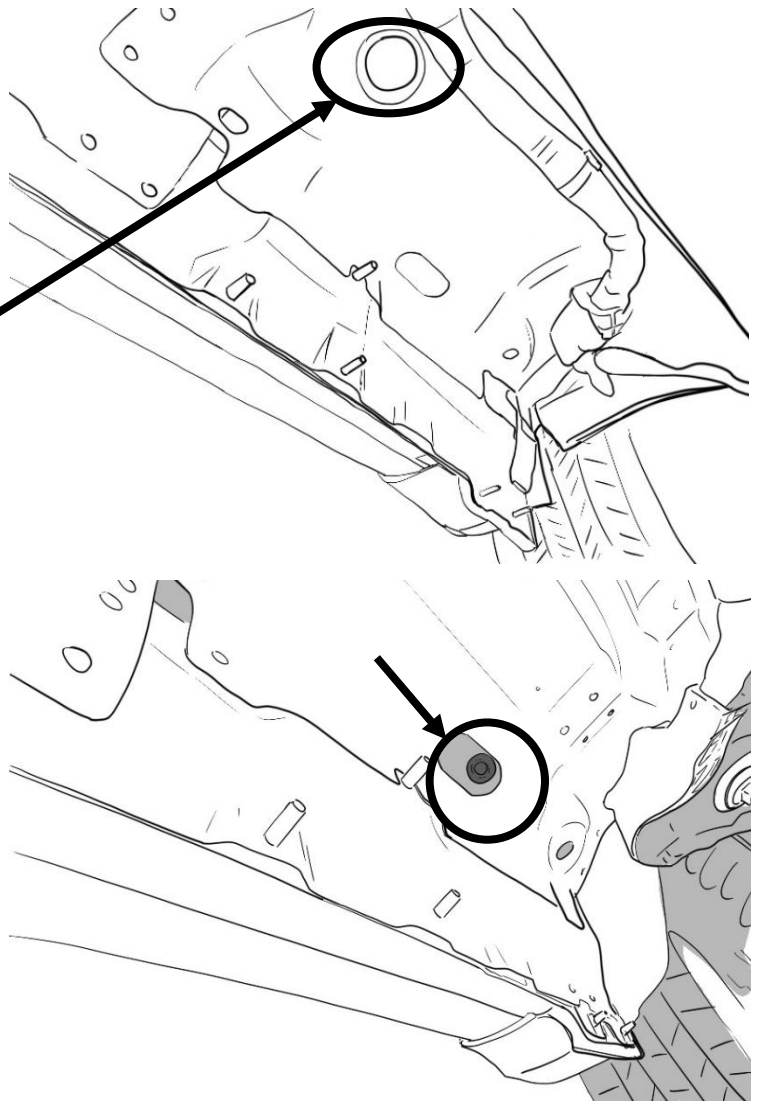

On some vehicles, the floor grommet will be a smaller rubber plug that sits inside an underside cavity. Due to the greater thickness, an incision of the plastic conduit to the appropriate branch of the power step main harness (J) may be necessary to fit through the hole.

9

Inside the vehicle cabin, remove the driver-side front kick panel and bottom door sill plate. Peel back the carpet to access the hole where the grommet was removed. Feed the wires through.

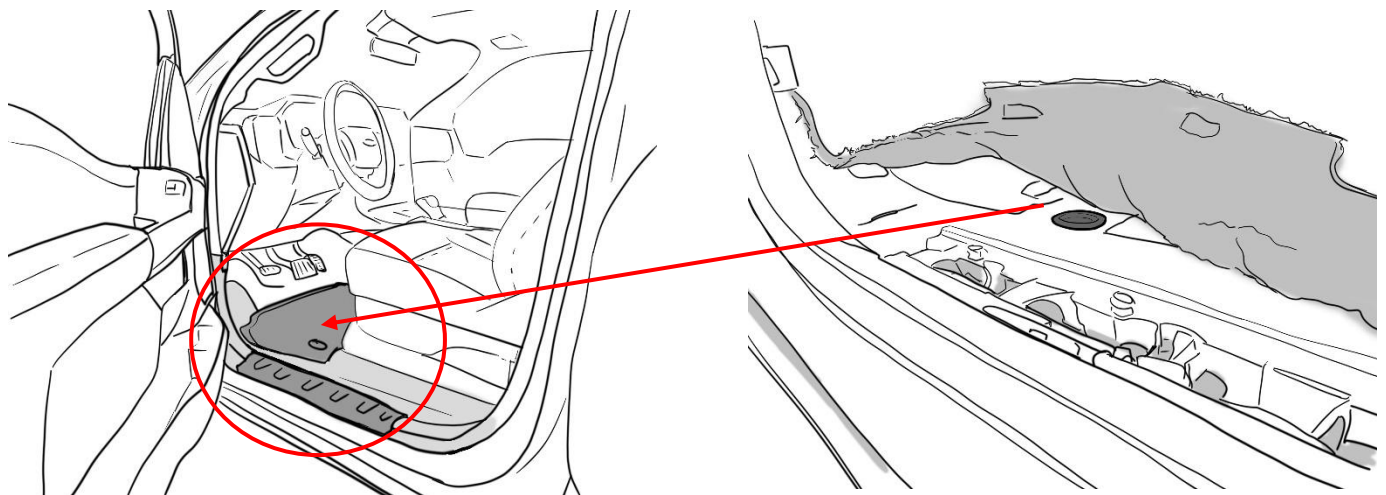

10 Attach the main harness (J) to one LED Y-Harness (K). Then attach the LED Y-Harness to the motor (do this for driver side first). Repeat for passenger side.

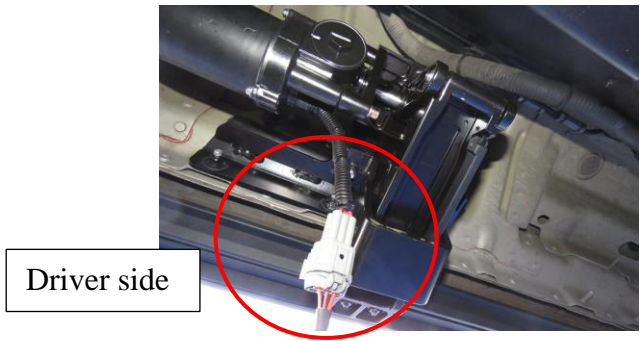

Driver side

11 Locate the black BCM (body control module) under the steering wheel, behind the OBD-II Port. Slide the BCM out of the holding bracket by pushing the locking tab in the center and pulling outwards in the direction of the rail for easier access to wires.

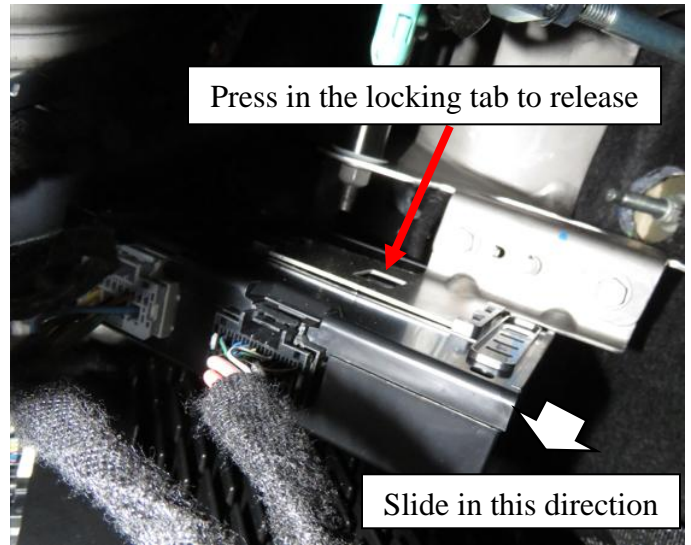
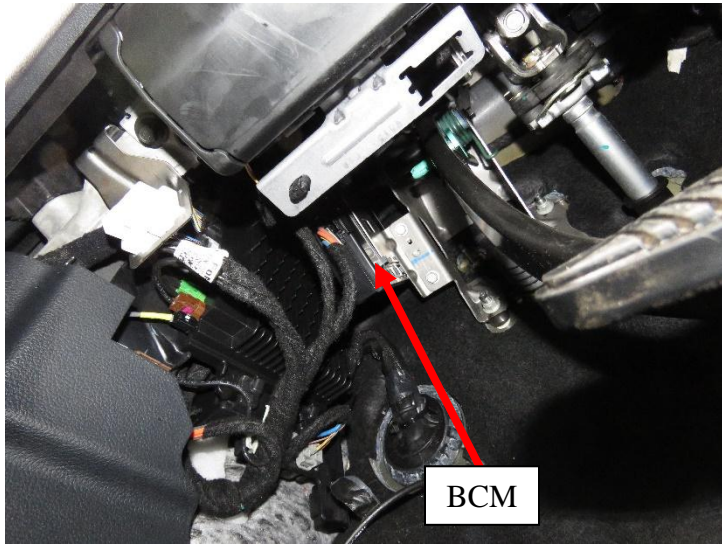

12 On the black plug of the BCM, identify the blue/green stripe and white/green stripe wires. Connect the High and Low wires from the main harness (J) using the supplied wire taps (L). After successfully connecting the wires, return the BCM back into its place and check that it is secure.

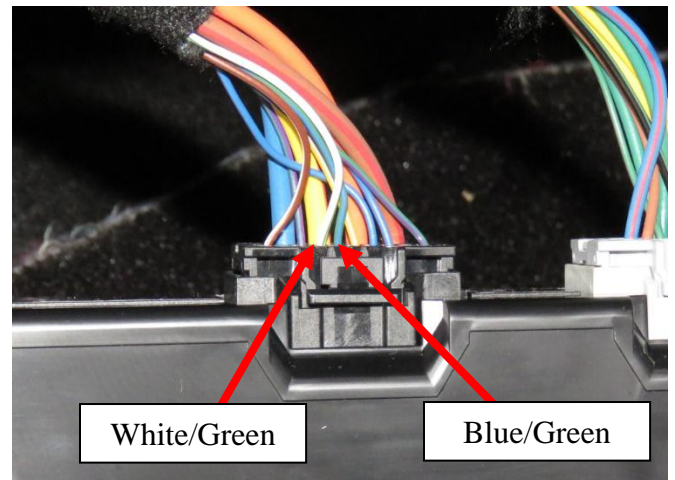
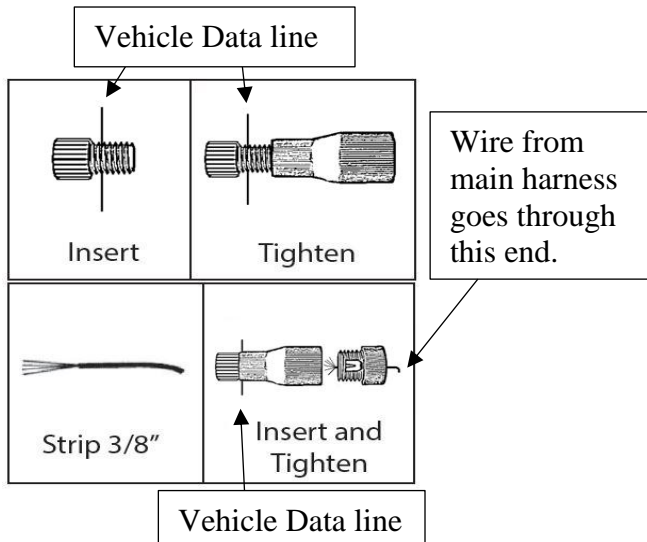

Factory CAN Wire/ Data Line	Power Step Main Harness Wire Color
Green with Blue Stripe (High)	White (CAN-H)
White with Green Stripe (Low)	Yellow (CAN-L)

*NOTE: If board does not move during troubleshooting, flip the CAN Signal High and Low wires.

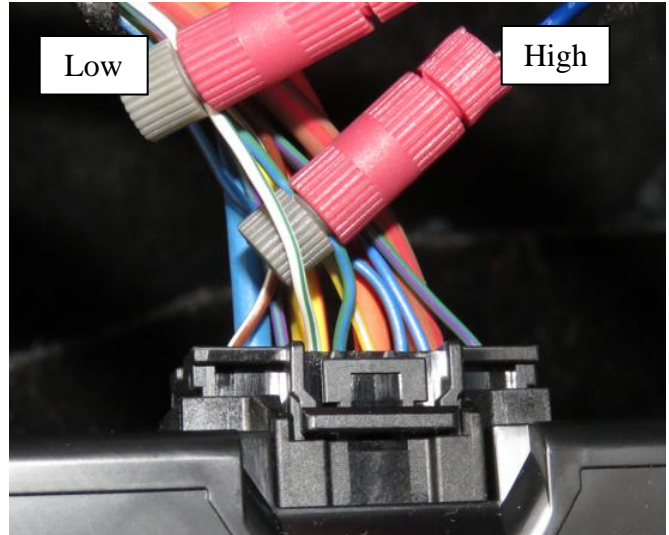

- 13** Plug in LED lights (N) into LED Y-Harness (K) and attach them to the bottom of the rocker panel. Use provided 3M double sided adhesive tape on back of LED light (N). Replace Fuse into Fuse Box.

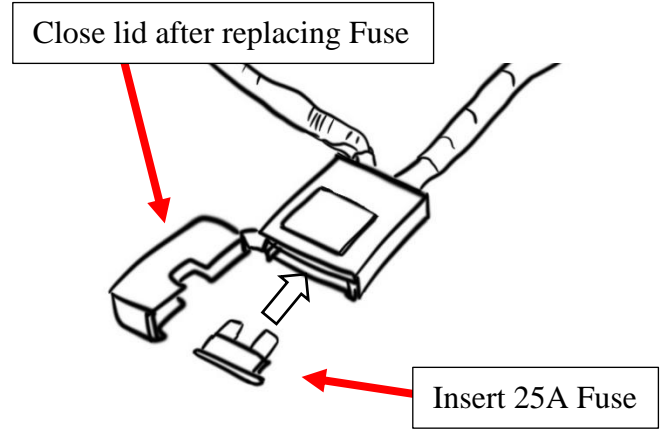
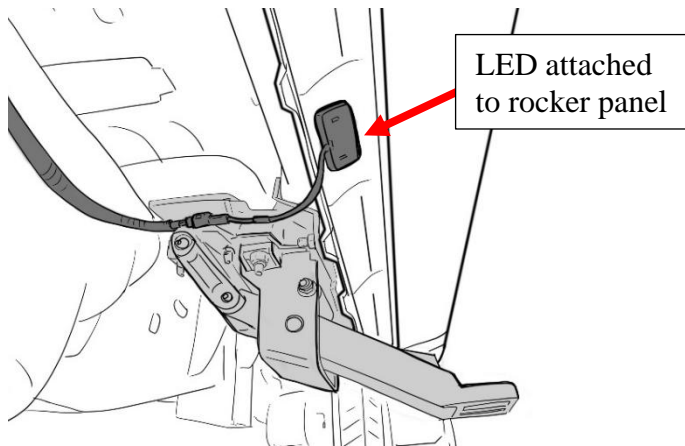

- 14** Check to make sure the harnesses on the Driver Side/Left Front Bracket Assembly (A) and Passenger Side Front Bracket Assembly (C) are connected to the main harness (J) via the LED-Y harnesses (K).

*NOTE: The linkage arms on the front bracket assemblies will not move unless both motors are connected.

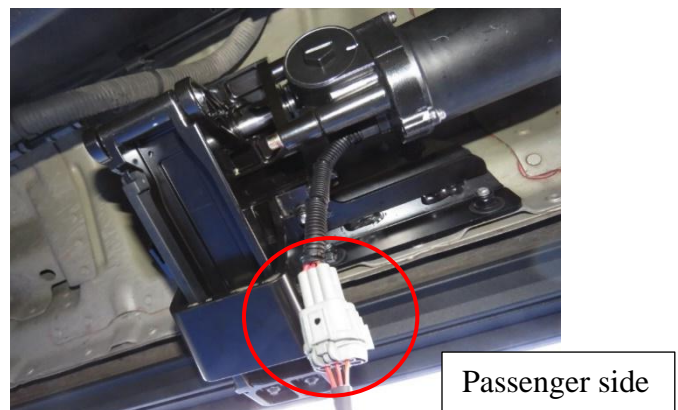

15

Seal the grommet with RTV Silicone Sealant.

Hide wires and reattach the kick panel with the carpet fully unfurled in its original position. Reattach the door sill panel and check to make sure there are no obstructions or potential snag points around the brake pedal area.

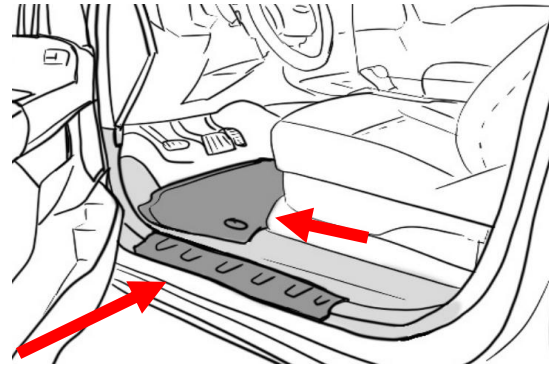
**16**

Prepare the power step boards. Locate the end of the boards and slide the M6 Carriage Bolts (E) into the channel on the underside of the board. Insert a total of 4 carriage bolts (E).

Carriage Bolt Channel

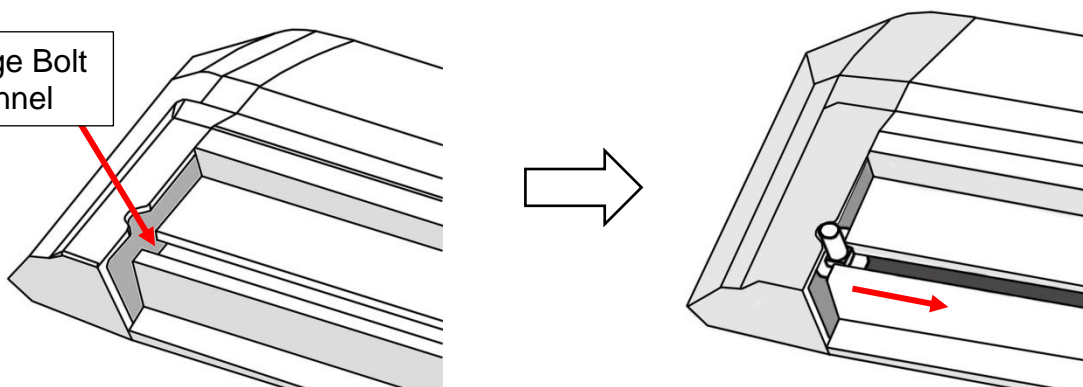

Use the notch in the board's end caps to feed the bolts into the channel.

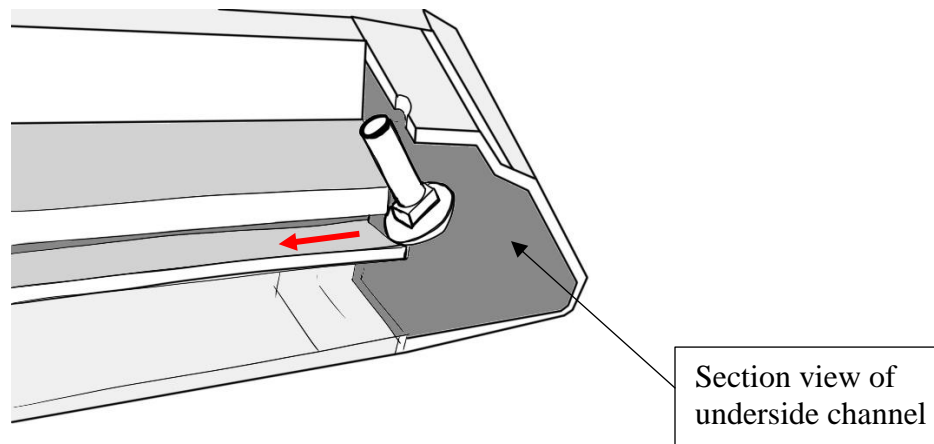
**17**

Perform a function check by closing the driver side front door and opening it again. The front bracket assembly (A) motor should activate the linkage arm and move it into the down or "deployed" position.

After deploying linkage arms, unplug main harness connector while front door is open to hold the board in the deployed position for running board installation.

Line up the carriage bolts (E), under the power step boards, with the slots on the linkage arms (A & B). Insert the 4 carriage bolts (E) into the slots on front and rear linkage arms. Adjust board to desired position. Moderately hand tighten the flange nuts (G) onto the carriage bolts.

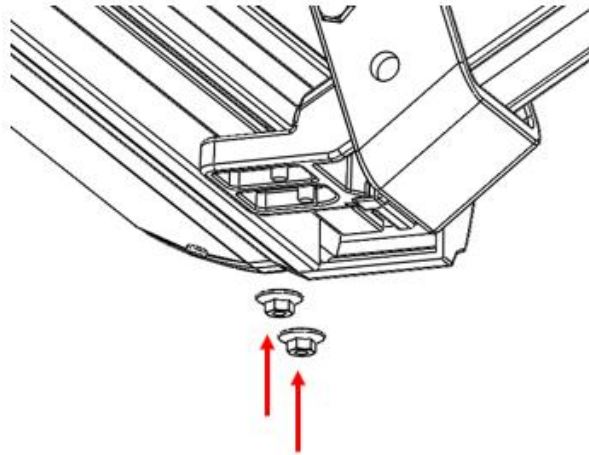

Once the board is adjusted, plug in main harness (J) connector to return power to the linkage arms. Open and close doors several times to deploy and retract the steps to settle the steps into their natural alignment. After cycling the step, tighten all hardware on the board and brackets.

Some further adjustment may be required for desired step position. Repeat for passenger side.

18

Perform system check and troubleshooting. If board is making irregular movements or noise, readjust the boards as follows:

- a) With board deployed loosen 6mm flange nuts under board.
- b) Leave the flange nuts slightly less than snug.
- c) Open and close door several times for board to settle into position.
- d) With the step in the deployed position, gradually tighten flange nuts while alternating between each. Do not over tighten.

If board is making abnormal noise or the motion is binding, repeat steps “a” through “d”.

Note: If the above method does not resolve the issue, the brackets mounting to the vehicle may not be aligned properly with the vehicle. In this case, remove the board and realign brackets before attempting steps “a” to “d” once again.

Reinstall any remaining trim panels if necessary. Check and make sure all hardware is fully tightened. Perform a final system check. Finish.

