

iBoard®

iBoard® by APS

PART#: IB-R406&R416

READ INSTRUCTIONS CAREFULLY BEFORE STARTING INSTALLATION. REMOVE CONTENTS FROM BOX AND VERIFY ALL PARTS ARE PRESENT. ASSISTANCE IS RECOMMENDED.

*ROCKER PANEL MOUNT
*DRILLING IS REQUIRED

Fastener Size	Tightening Torque (ft-lbs)	Required
6mm	6-7	√
8mm	16-18	√
10mm	31-32	√
12mm	56-58	X
14mm	92-94	X

PART LIST

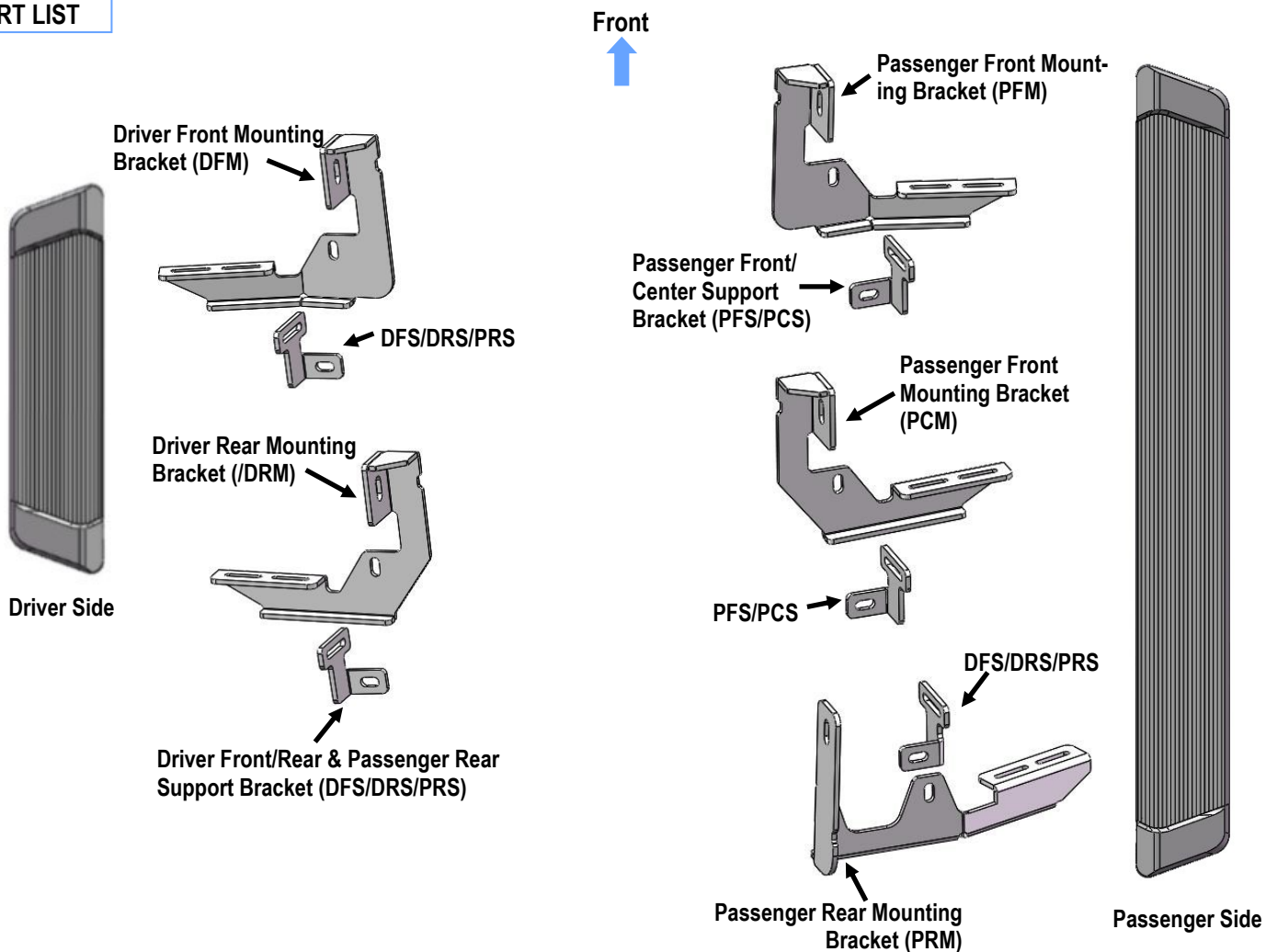

Customer Support: info@iboardauto.com

iBoard®



STEP 1

Starting on the passenger front side of the vehicle, locate the factory holes in the inner body panel closest to the front tire opening. (Fig 1). Remove the rubber plugs. **NOTE:** Mounting locations may be covered with heavy undercoating.

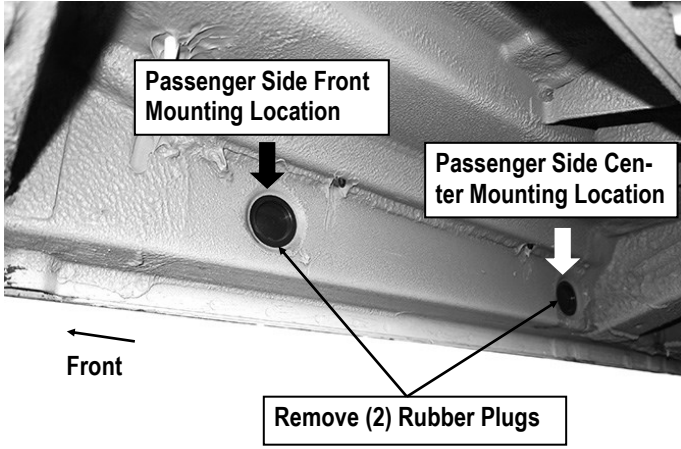

(Fig 1) Passenger Side Front & Center Mounting Locations

STEP 2

Select (2) M10 Bolt Plate and (2) M10 Plastic Washer. Insert the M10 Bolt Plates into the mounting holes and thread (1) M10 Plastic Washer on each Bolt Plate to hold the bolt plates in place, (Fig 2).

IMPORTANT: The Plastic Washer is designed to prevent the Bolt Plate from falling into the body panel and to aid in Bracket installation.

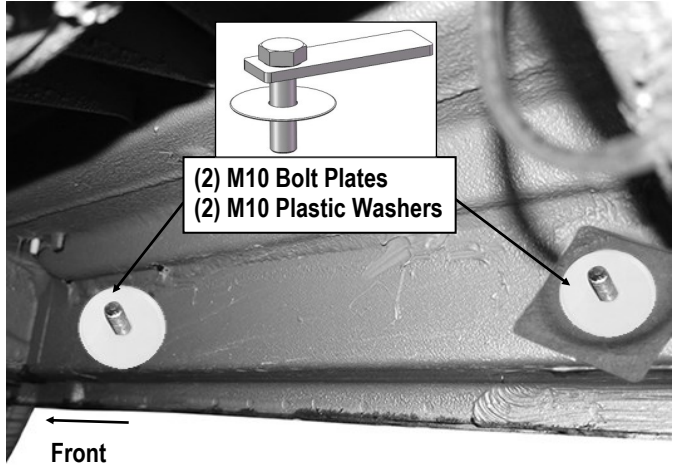

(Fig 2) M10 Bolt Plate Installed (On Passenger Side Front & Center Mounting Location)

iBoard®

STEP 3

Attach the Passenger Front Mounting Bracket (PFM) to the installed M10 Bolt Plate with (1) M10 Flat Washer, (1) M10 Lock Washer and (1) M10 Hex Nut, (Fig 3). Do not fully tighten hardware at this time.

STEP 4

Next, select (1) Passenger Front Support Bracket (PFS/PCS). Attach the Support Bracket to the back of the Passenger Front Mounting Bracket (PFM) with (1) M8X1.25-25mm Hex Bolt, (2) M8 Large Flat Washers, (1) M8 Lock washer and (1) M8 Hex Nuts, (Fig 3). Line up the mounting flange on the Support Bracket with the **back** of the pinch weld, (Fig 4). Do not fully tighten hardware at this time.

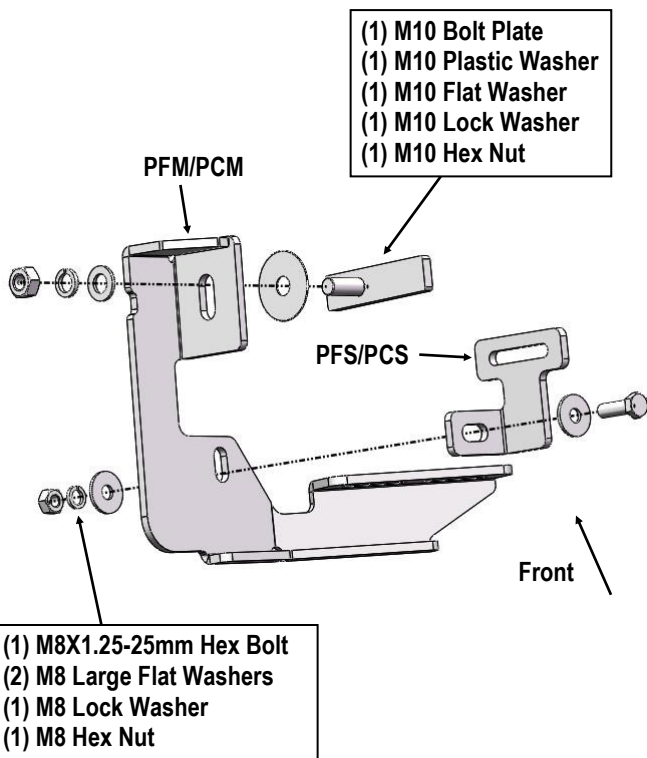

(Fig 3) Passenger Front Mounting Bracket (PFM/PCM) and Passenger Front Support Bracket (PFS/PCS) Installation

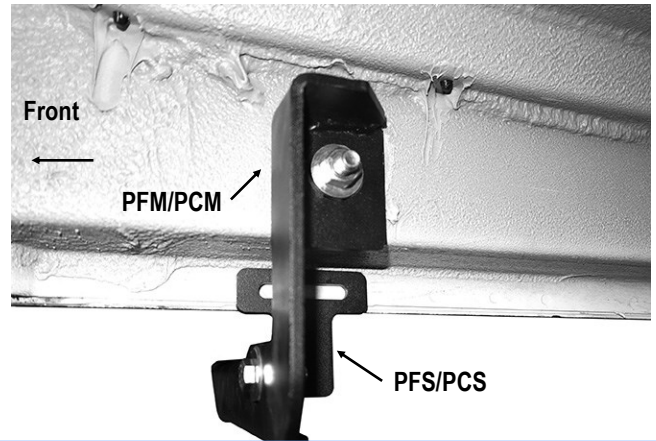

(Fig 4) Passenger Front Brackets Installed

STEP 5

Move to the passenger side center mounting location. Repeat **Steps 1—4** to install the Passenger Center Mounting Bracket (PCM) and Passenger Center Support Bracket (PFS/PCS).

Note: Passenger Front & Center Support Bracket (PFS/PCS) are universal.

STEP 6

Move to the passenger side rear mounting location, (Fig 5). Repeat **Steps 1—4** to install the Passenger Rear Mounting Bracket (PRM) and Passenger Rear Support Bracket (DFS/DRS/PRS), (Fig 6 & 7).

Note: Passenger Rear Support Bracket, Driver Front Support Bracket and Driver Center Support Bracket are universal.

iBoard®

STEP 7

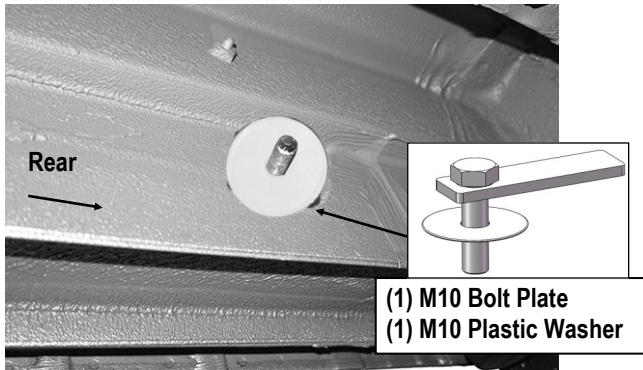

(Fig 5) Passenger Side Rear Mounting Location

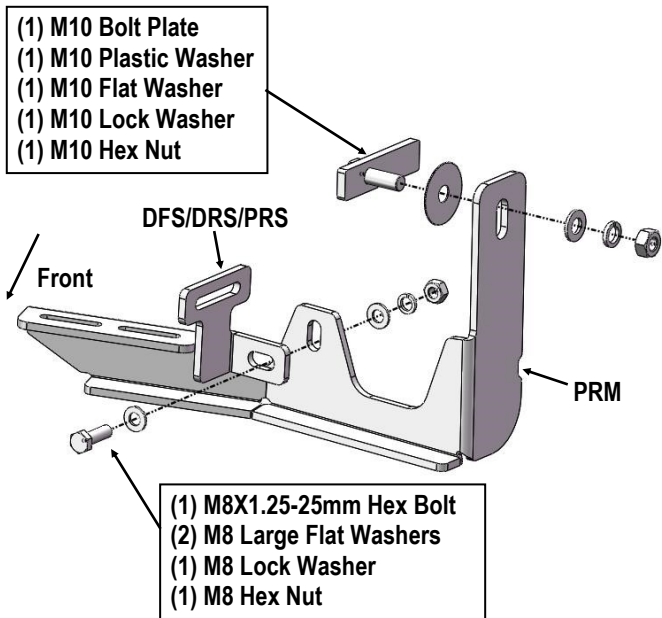

(Fig 6) Passenger Rear Mounting Bracket (PRM) and Passenger Rear Support Bracket (DFS/DRS/PRS) Installation

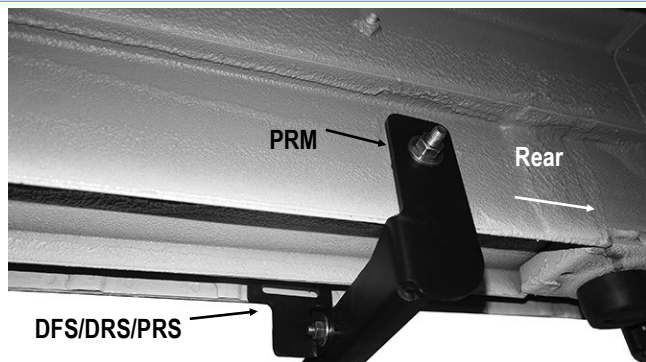

(Fig 7) Passenger Rear Bracket Installed

Select the passenger side Running Board (the long one). Slip (3) M6x1-20mm Square Head Bolts into each bottom channel (Fig 8). Carefully position the Running Board onto the (3) Mounting Brackets.

IMPORTANT: Do not slide the Running Board on the Brackets or the bottom surface of the board will be damaged. Attach the Running Board to each Mounting Bracket with (2) M6x1-20mm Square Head Bolts, (2) M6 Large Flat Washers and (2) M6 Nylon Lock Nuts (Fig 9). Do not fully tighten hardware at this time.

Level and adjust the Running Board and fully tighten the Bracket to vehicle hardware only.

M6X1-20mm Square Head Bolts

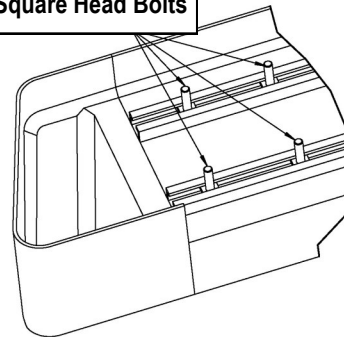

(Fig 8) Slip M6X1-20mm Square Head Bolts Into The Bottom Channels

(2) M6X1-20mm Square Head Bolts
(2) M6 Large Flat Washers
(2) M6 Nylon Lock Nuts

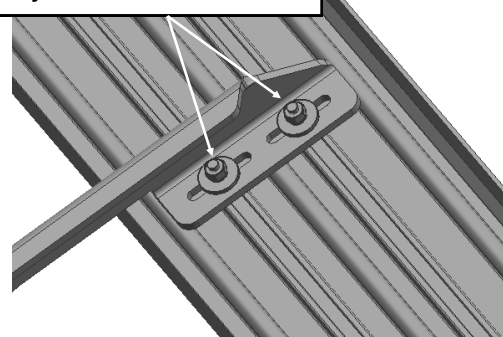

(Fig 9) Running Board Installed Onto Mounting Bracket (Example)

iBoard®

STEP 8

Make sure the Brackets are level to the vehicle. Line up the slots on each Support Bracket with the back of the pinch weld. Mark the location of the slots onto the pinch weld, (**Fig 10**). **IMPORTANT:** Do not drill too close to the bottom edge of the pinch weld. Adjust Support Brackets and/or Mounting Brackets to move slot in support bracket up away from the bottom edge of the pinch weld.

Once the Running Board and Brackets are properly adjusted and slot locations marked, remove the Running Board and Support Brackets. Use a 1/4" drill bit to drill the (2) holes through the pinch weld for each Support Bracket, (**Fig 10**). **NOTE:** Drill holes toward outer ends of slot. Avoid drilling through welds in pinch weld.

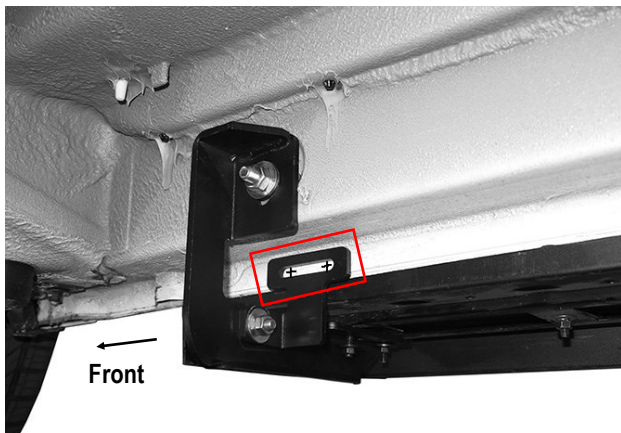

(Fig 10) Mark location of each Support Bracket onto pinch weld before drilling

STEP 9

Attach each Support Bracket to the pinch weld with (2) M6X1-25mm Hex Bolts, (4) M6 Large Flat Washers, (2) M6 Lock Washers and (2) M6 Hex Nuts, (**Fig 11**). Repeat this Step to attach all (3) Support Brackets. Tighten the hardware attaching the Support Brackets to the vehicle only.

- (2) M6X1-25mm Hex Bolts
- (4) M6 Large Flat Washers
- (2) M6 Lock Washers
- (2) M6 Hex Nuts

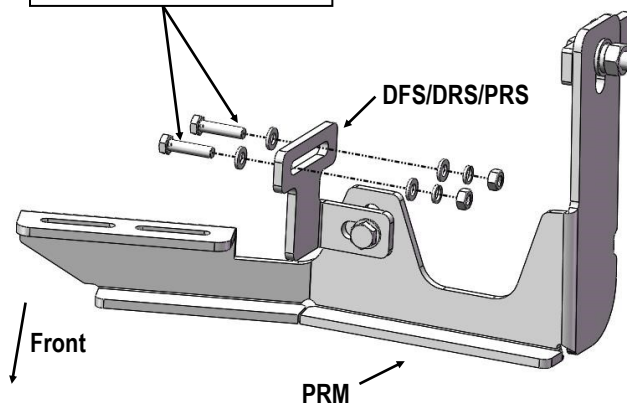

(Fig 11) Attach Support Bracket To Pinch Weld

STEP 10

Move to the Driver side of the vehicle (**Fig 12**). Repeat **Steps 1-4** to install the driver side front & rear Mounting Brackets and Support Brackets, (**Fig 13**). Do not fully tighten hardware at this time.

Note: Passenger Rear Support Bracket, Driver Front Support Bracket and Driver Center Support Bracket are universal.

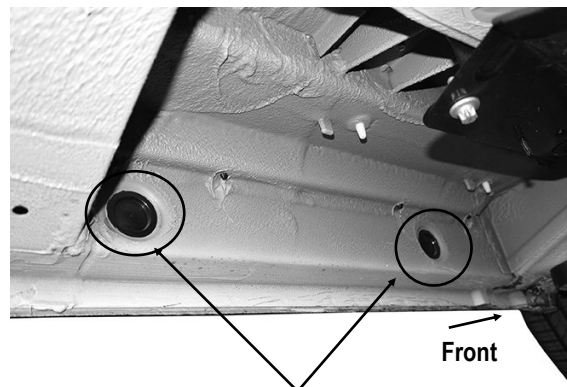

(Fig 12) Driver Side Front & Rear Mounting Locations

iBoard®

STEP 11

Repeat **Steps 7—9** to drill holes on the pinch weld and install the support brackets, (**Fig 13**), and install the Driver Side Running Board (the short one).

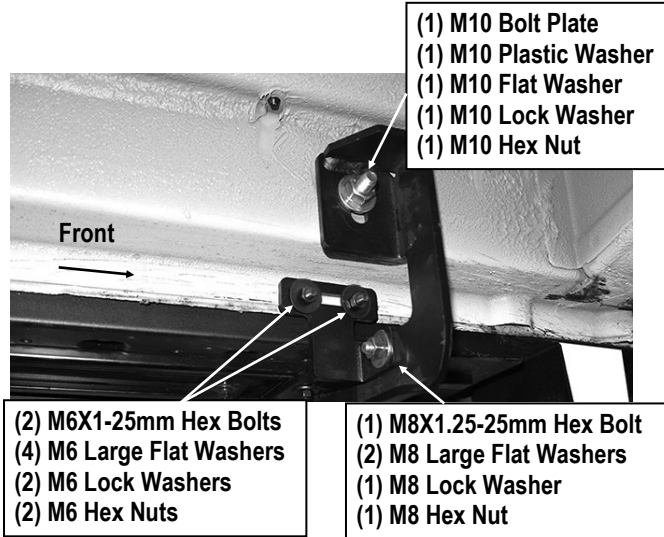

(Fig 13) Driver Side Front Bracket Installation

STEP 12

Level and adjust the Running Board and fully tighten all hardware. And then installation completed.

Attention

Do periodic inspections to the installation to make sure that all hardware is secure and tight.

In order to protect your bars/boards, please use only mild soap/non-abrasive products for cleaning.