

iBoard®

iBoard® by APS

PART#: IB-063

READ INSTRUCTIONS CAREFULLY BEFORE STARTING INSTALLATION. REMOVE CONTENTS FROM BOX AND VERIFY ALL PARTS ARE PRESENT. ASSISTANCE IS RECOMMENDED.

*BODY FRAME MOUNT
*NO DRILLING REQUIRED

Fastener Size	Tightening Torque (ft-lbs)	Required
6mm	6-7	√
8mm	16-18	X
10mm	31-32	X
12mm	56-58	√
14mm	92-94	X

PART LIST

Front
↑

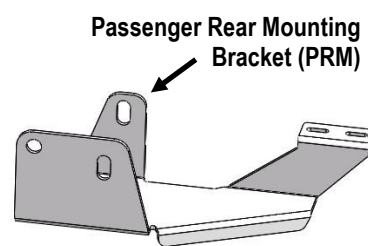
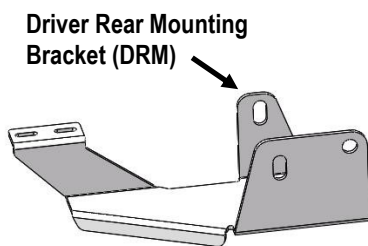
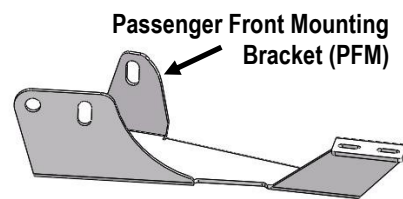
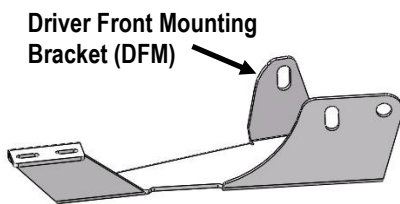

Customer Support: info@iboardauto.com

iBoard®

Hardware Package A (For Bracket Installation)

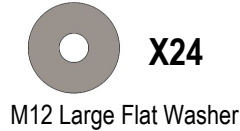

Hardware Package B (For Aluminum Step Bar Installation Only, Not Supply to Stainless Steel Step Bar)

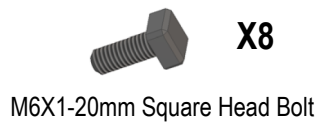

Hardware Package C (For Stainless Steel Step Bar Installation Only, Not Supply to Aluminum Step Bar)



STEP 1

Start installation from the driver side front of the vehicle. Remove the factory hex bolts securing the plastic rocker panel cover on the driver side to the vehicle, (Figs 1 & 2). Place the cover on a clean surface.

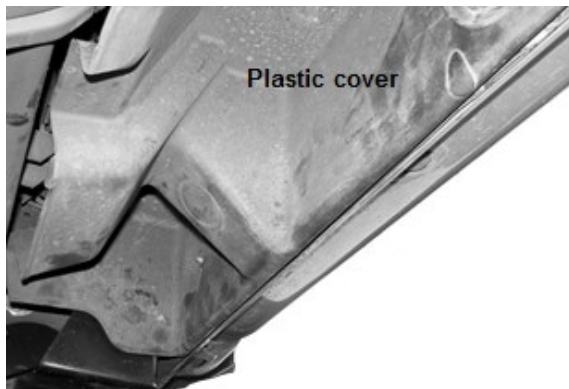

(Fig 1) Driver Side Front Body Mount

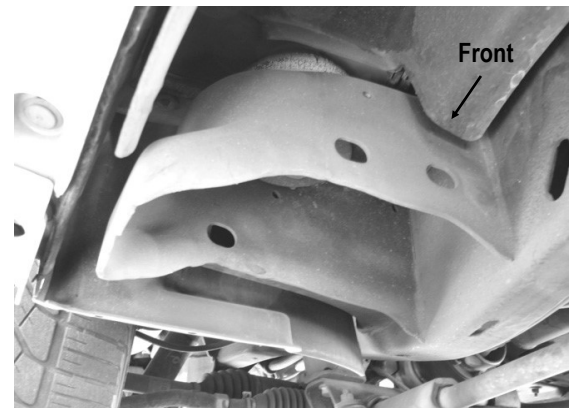

(Fig 2) Driver Side Front Body Mount
(After Plastic Cover Removed)

iBoard®

STEP 2

Position the Driver Front Mounting Bracket up to the underside of the body mount-frame channel. Bolt the Bracket to the back of the frame channel with (2) M12X1.75-45mm Hex Bolts, (4) M12 Large Flat Washers, (2) M12 Lock Washers and (2) M12 Hex Nuts, **(Figs 3 & 4)**. Insert (1) M12X1.75-30mm Shorter Hex Bolt with (2) M12 Large Flat Washers, (1) M12 Lock Washer and (1) M12 Hex Nut into the front tab on the Mounting Bracket and into the frame channel. Do not fully tighten hardware at this time.

IMPORTANT: Only use the (2) M12X1.75-30mm Hex Bolt (**Shorter**) in the front mounting location for the driver side and passenger side **Front Mounting Brackets**.

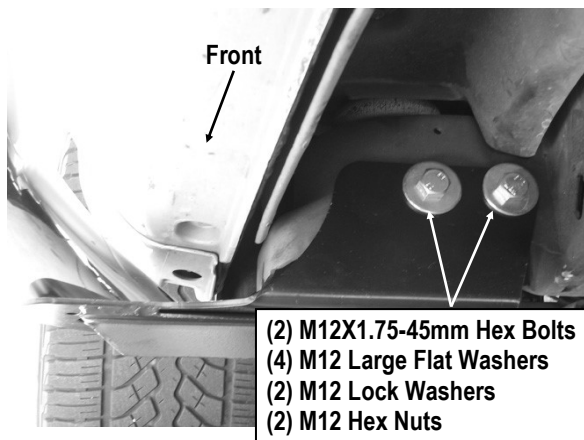

(Fig 3) Driver Side Front Mounting Bracket Installed
(After Plastic Cover Removed)

STEP 3

Move to the driver side rear mounting location, **(Fig 5)**. Repeat **Steps 1 & 2** for the Driver Rear Mounting Bracket installation with (3) M12X1.75-45mm Hex Bolts, (6) M12 Large Flat Washers, (3) M12 Lock Washers and (3) M12 Hex Nuts, **(Figs 6 & 7)**. Do not fully tighten hardware at this time.

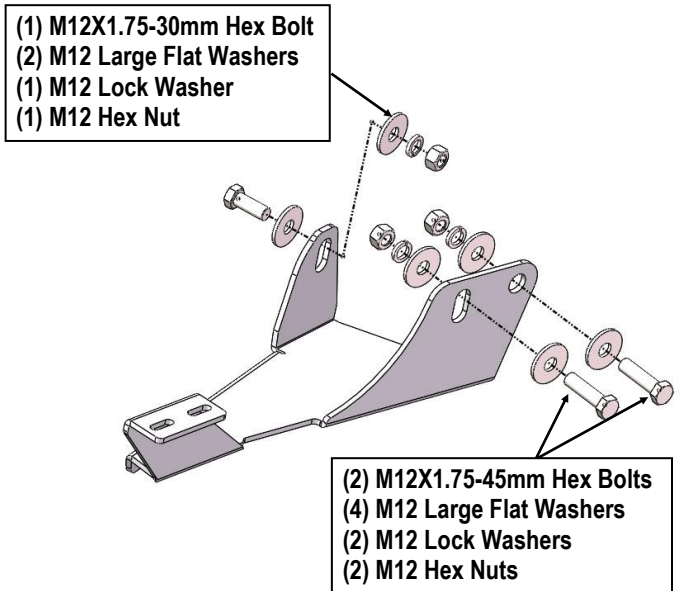

(Fig 4) Driver Front Mounting Bracket Installation



(Fig 5) Driver Side Rear Body Mount Location
(After Plastic Cover Removed)

iBoard®

STEP 5

Aluminum Step Bar Installation:

Select a **Aluminum Step Bar**. Slip (2) M6x1-20mm Square Head Bolts into each bottom channel (**Fig 8**). Carefully position the Step Bar onto the (2) Mounting Brackets.

IMPORTANT: Do not slide the Step Bar on the Brackets or the bottom surface of the board will be damaged. Attach the Step Bar to each Mounting Brackets with (2) M6x1-20mm Square Head Bolts, (2) M6 Large Flat Washers and (2) M6 Nylon Lock Nuts, (**Fig 9**). Do not fully tighten at this time.

Level and adjust the Step Bar and fully tighten all hardware.

Repeat **Steps 1-5** for the other side Step Bar installation. **The installation is completed!!!**



(Fig 8) Slip M6X1-20mm Square Head Bolts Into The Bottom Channels

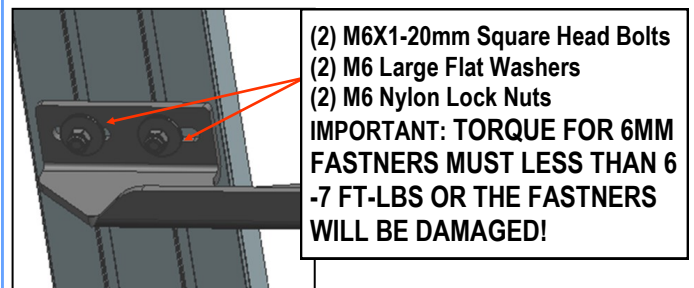

(Fig 9) Running Board Installed Onto Mounting Bracket

- (3) M12X1.75-45mm Hex Bolts
- (6) M12 Large Flat Washers
- (3) M12 Lock Washers
- (3) M12 Hex Nuts

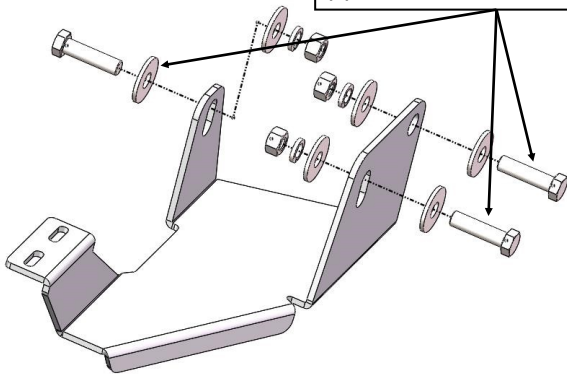

(Fig 6) Driver Rear Mounting Bracket Installation



(Fig 7) Driver Rear Mounting Bracket Installed

STEP 4

Once all (2) mounting brackets are installed, then proceed to the Step Bar installation. According to the style of Step Bar proceed to the correct installation STEPS.

Note: Aluminum Step Bar refer to STEP 5; Stainless Steel Step Bar skip to STEP 6.

iBoard®

STEP 6

Stainless Steel Step Bar Installation:

Select a **Stainless Steel Step Bar** (with the U-Sliders installed on the Bar). Loosen the U-Sliders, reposition the U-Sliders onto the board according to the (2) Installed Mounting Brackets location, (**Fig 10**). Re-secure the U-Sliders on the Step Bar. Attach the Step Bar to the installed Mounting Brackets with (4) M6X1-20mm Hex Bolts, (4) M6 Large Flat Washers & (4) M6 Lock Washers, (**Fig 11**). Do not fully tighten hardware at this time.

Level and adjust the Step Bar and fully tighten all hardware.

Repeat **Steps 1-4 and 6** for the other side Step Bar installation.

The installation is completed!!!

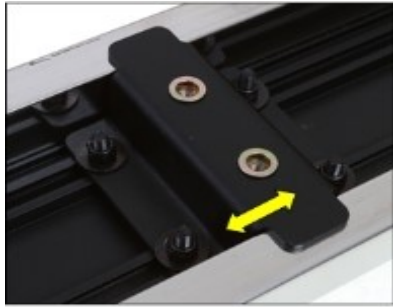

(Fig 10) Slide & line up the U-Slider with the installed mounting brackets along bottom channel

- (2) M6X1-20mm Hex Bolts
- (2) M6 Large Flat Washers
- (2) M6 Lock Washers

IMPORTANT: TORQUE FOR 6MM FASTNERS MUST LESS THAN 6-7 FT-LBS OR THE FASTNERS WILL BE DAMAGED!

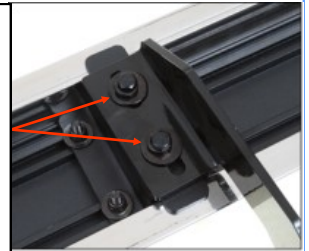

(Fig 11) Step Bar Installed on Bracket Installed (Example)

Attention

Do periodic inspections to the installation to make sure that all hardware is secure and tight.

In order to protect your bars/boards, please use only mild soap/non-abrasive products for cleaning.