

# iBoard®



Scan for  
Installation Video

## iBoard® by APS

PART#: IB-351C&H

READ INSTRUCTIONS CAREFULLY BEFORE STARTING INSTALLATION. REMOVE CONTENTS FROM BOX AND VERIFY ALL PARTS ARE PRESENT. ASSISTANCE IS RECOMMENDED.

\*ROCKER PANEL MOUNT  
\*NO DRILLING REQUIRED / CUTTING MAY BE REQUIRED

Fastener Size	Tightening Torque (ft-lbs)	Required
6mm	6-7	X
8mm	16-18	√
10mm	31-32	√
12mm	56-58	X
14mm	92-94	X

### PART LIST

#### Driver Side Step Bar

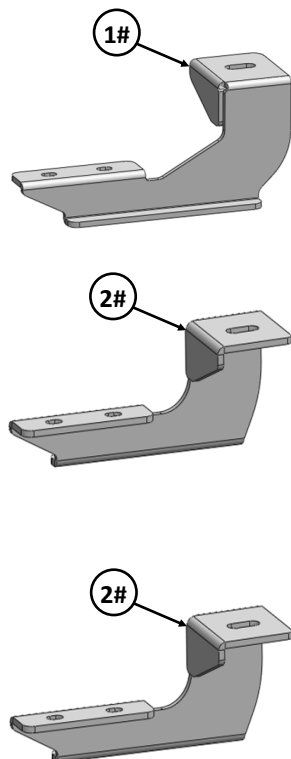

Front

#### Passenger Side Step Bar

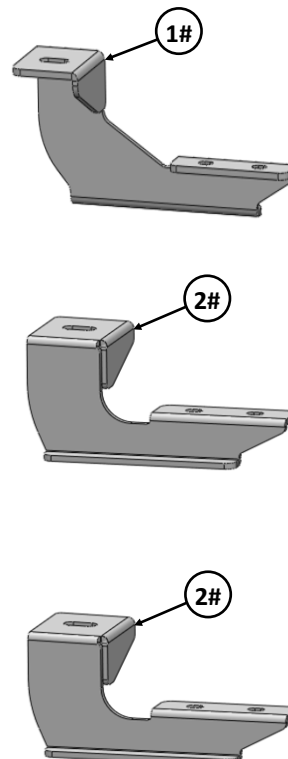



Mounting Bracket List					
Item	QTY	Description	Item	QTY	Description
1#	2	Driver & Passenger Front Mounting Brackets	2#	4	Mounting Brackets

Hardware Package A (For Bracket Installation)					
Item	QTY	Description	Item	QTY	Description
1#	6	M10 Bolt Plates	4#	6	M10 Lock Washers
2#	6	M10 Plastic Washers	5#	6	M10 Hex Nuts
3#	6	M10 Large Flat Washers			



1#



2#



3#



4#



5#

Hardware Package B (For Stainless Steel Step Bar Installation)					
Item	QTY	Description	Item	QTY	Description
1#	12	M8X1.25-35mm Carriage Bolts	3#	12	M8 Nylon Lock Nuts
2#	12	M8 Large Flat Washers	4#	6	Sliders (Packed with Step Bars)

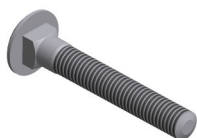

1 #



2 #



3 #



4 #



## STEP 1

Start installation from the passenger side of the vehicle. Removing the factory hex nuts securing the bottom of the plastic rocker cover to the bottom of the vehicle, (Figs 2 & 3).

**VERY IMPORTANT:** Installation can be done without removing the plastic rocker cover but it may be easier to cut with the cover removed.

## STEP 2

Start from the passenger side front mounting location, (Fig 1). Loosen the screw in the center of the plastic plug in the floor panel and remove the plug, (Figs 2 & 3).

**IMPORTANT:** The plastic plug is made up of (2) pieces. You must remove both the outer plug and the inner clip, (Fig 3).

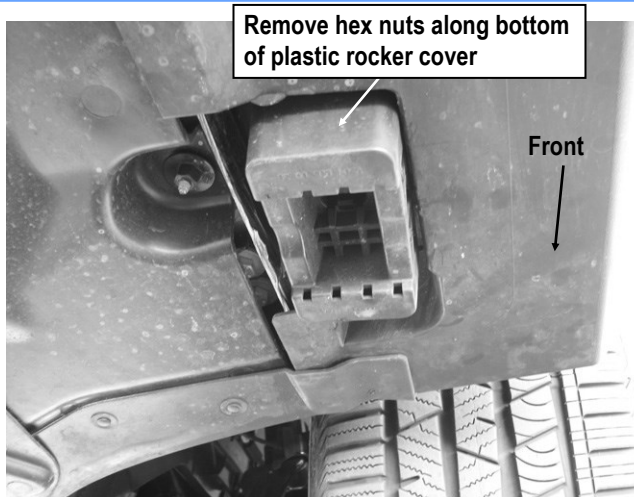

(Fig 1) Passenger Side Front Mounting Location

Remove hex nuts along bottom of plastic rocker cover

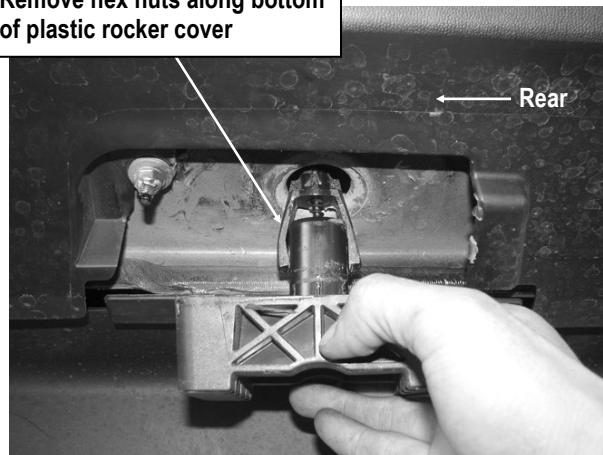

(Fig 2) Remove Plastic Plug

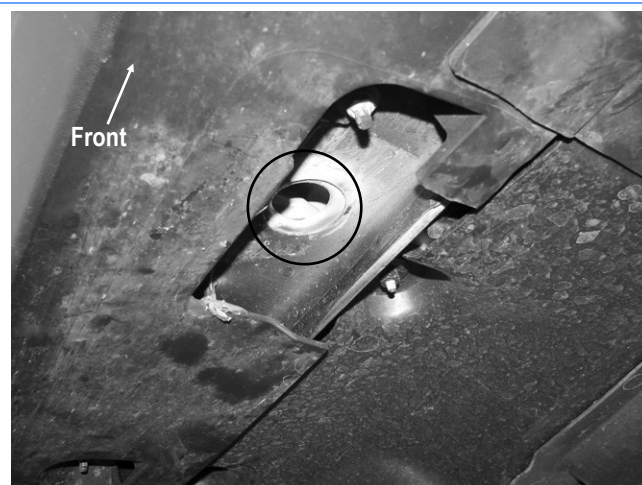

(Fig 3) Passenger Side Front Mounting Location

## STEP 3

Select (1) M10 Bolt Plate and (1) M10 Plastic Washer, (Fig 4). Thread the M10 Plastic Washer part way onto the Bolt Plate. Insert the Bolt Plate into the hole in the floor panel, (Fig 4). Thread the Plastic Washer down until it is tight against the floor panel.

**IMPORTANT:** The Plastic Washer is designed to prevent the Bolt Plate from pushing up into the body panel and to aid in installing the Bracket.

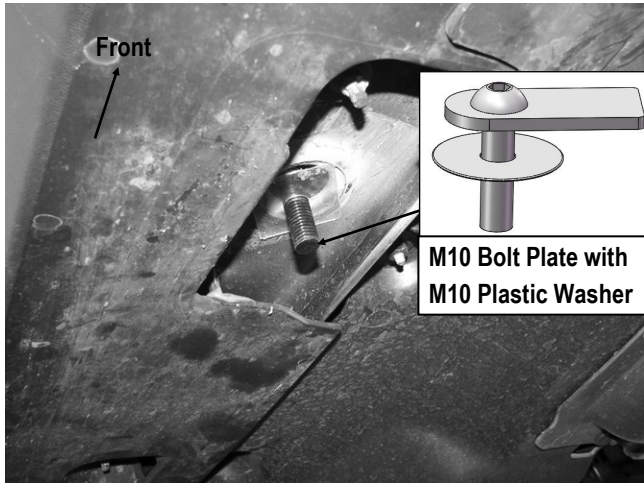

(Fig 4) Passenger Side Front Mounting Location

## STEP 4

Next, select the Driver Front Mounting Bracket. Attach the Bracket to the installed Bolt Plate with (1) M10 Large Flat Washer, (1) M10 Lock Washer and (1) M10 Hex Nut, (Fig 5). Do not fully tighten at this time.

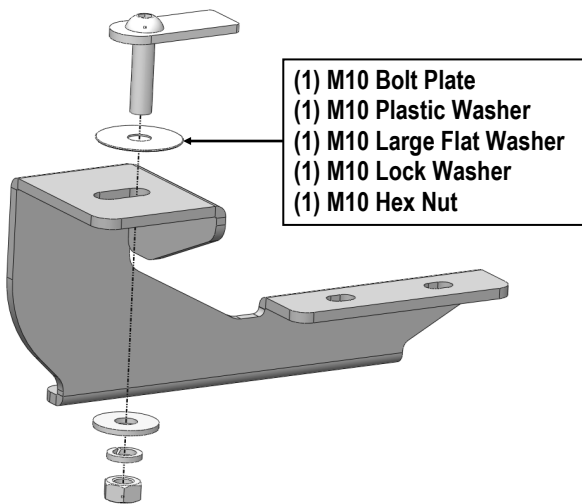

(Fig 5) Passenger Side Front Mounting Bracket Installation

## STEP 5

With the rocker cover loose, pull the cover away from the bottom of the body to locate the factory hole in the floor panel. **IMPORTANT:** Correct factory hole is approximately 47" back from the front wheel opening, (Fig 6).

Remove the plug from the hole, (Fig 7), and insert (1) M10 Bolt Plate with (1) M10 Plastic Washer as previously described in Step 2, (Fig 8).

Mark the location of the Bolt Plate, (or factory hole for Bolt Plate), onto the cover, (see white X-Fig 9A). Select (1) Mounting Bracket. Hold the Bracket in place with the slot in the Bracket lined up over the mark for the Bolt Plate. Mark the outline of the Bracket onto the plastic cover, (Fig 9B). Cut the cover only as necessary to clear the Bracket. **NOTE:** It may be necessary to trim the cover to allow for in and out movement during Bracket adjustment. Repeat Step 4 for the Mounting Bracket installation. Do not fully tighten at this time.

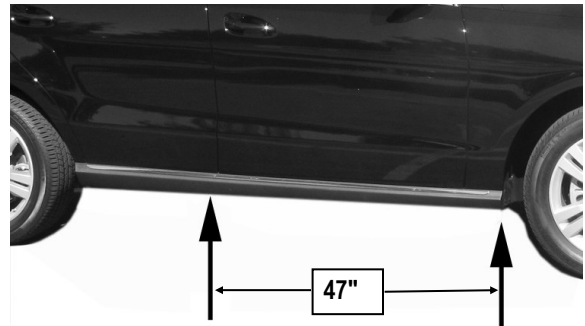

(Fig 6) Hole Used For Center Mounting Bracket

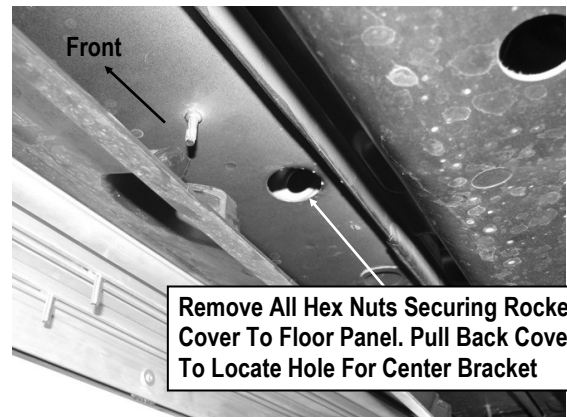

(Fig 7) Passenger Side Center Mounting Location

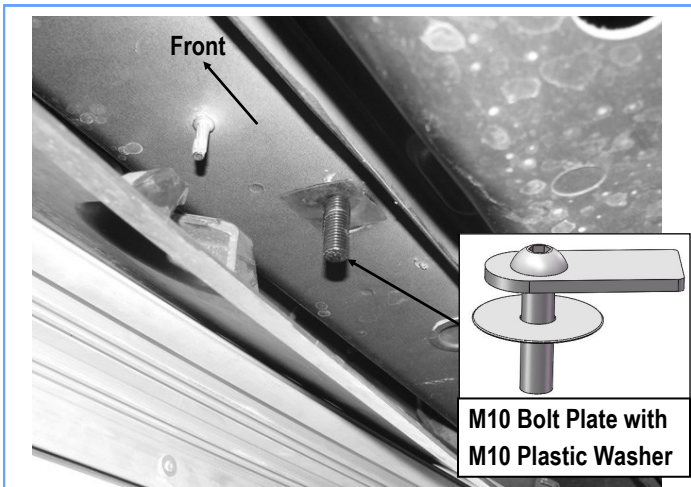

(Fig 8) Passenger Side Center Mounting Location

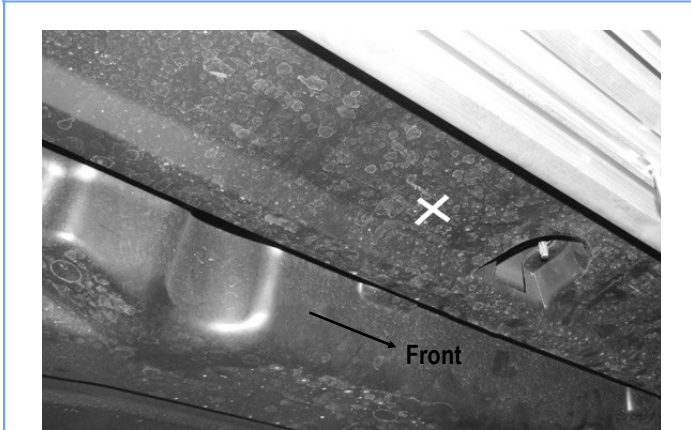

(Fig 9A) Mark The Location Of The Bolt Plate ( White X)

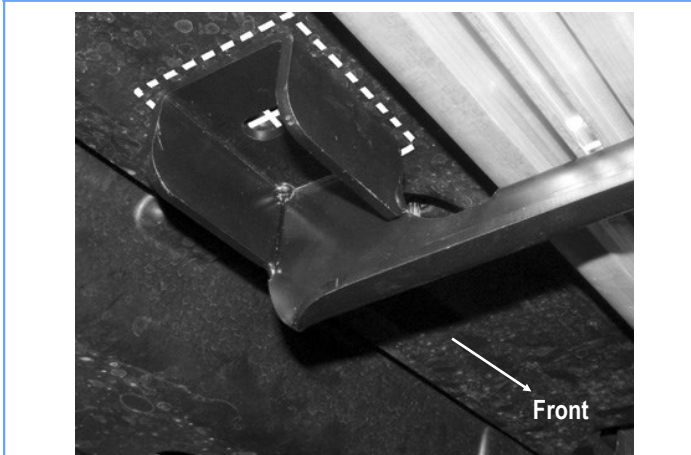

(Fig 9B) Hold the Bracket in place with the slot in the Bracket  
(Picture For Reference Only)

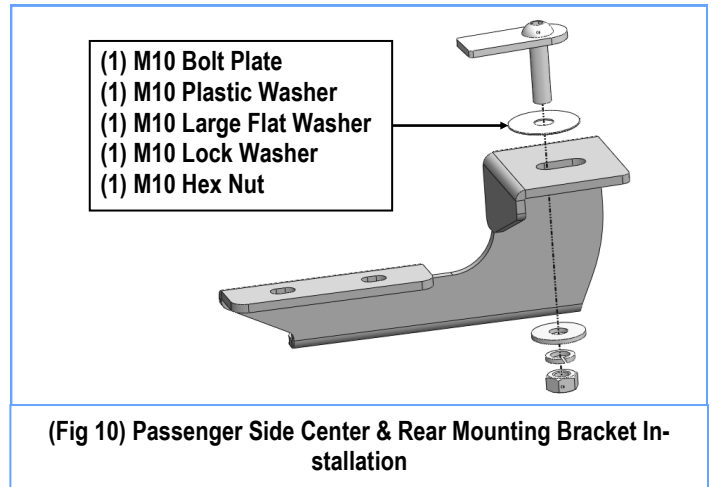

(Fig 10) Passenger Side Center & Rear Mounting Bracket Installation

## STEP 6

Move to the rear of the vehicle. Remove the plastic plug directly in front of the rear tire as described in **Step 2**, (Fig 11). Repeat **Steps 2 – 4** for passenger side rear Mounting Bracket installation, (Figs 12 & 10).

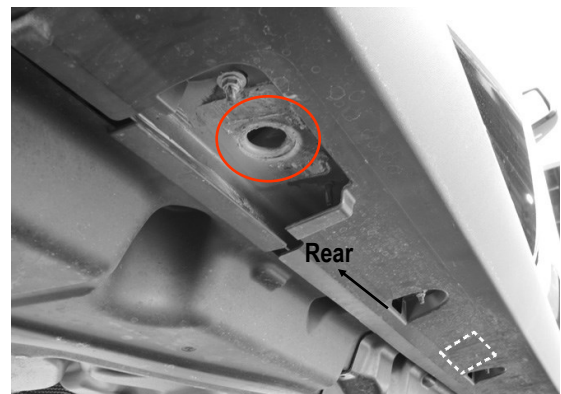

(Fig 11) Passenger Side Rear Mounting Location

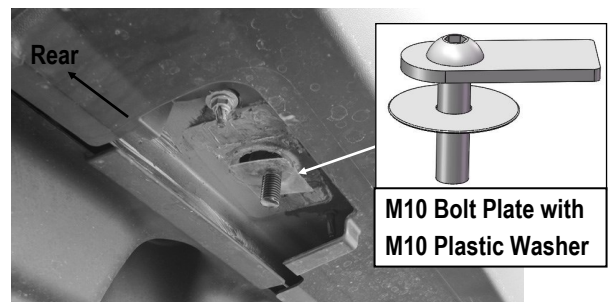

(Fig 12) Passenger Side Rear Mounting Location



## STEP 7

Once all (3) Passenger side mounting brackets are installed, then proceed to the Step Bar installation. (Figs 13 & 14)

- (1) Select (1) Slider and (2) M8X1.25-35mm Carriage Bolts;
- (2) Install (2) M8X1.25-35mm Carriage Bolts in (1) Slider.
- (3) Slide the Slider (with carriage bolts) to the **Step Bar**.
- (4) Repeat to install the other (2) sliders to the step bar.
- (5) Attach the Step Bar (with the Sliders) onto the installed mounting brackets. Position the Sliders to the installed brackets. Secure the Step Bar to the installed Brackets by using (6) M8 Large Flat Washers and (6) M8 Nylon Lock Nuts and (3) Sliders, (Fig 14). Do not fully tighten hardware at this time.

**Note:** The Sliders are packed with the Step Bars.

Level and adjust the Step Bar and fully tighten all hardware. Repeat **Steps 1-7** for the other side Step Bar installation. **The installation is completed!!!**

### Attention

Do periodic inspections to the installation to make sure that all hardware is secure and tight.

In order to protect your bars/boards, please use mild soap/non-abrasive products for cleaning only.

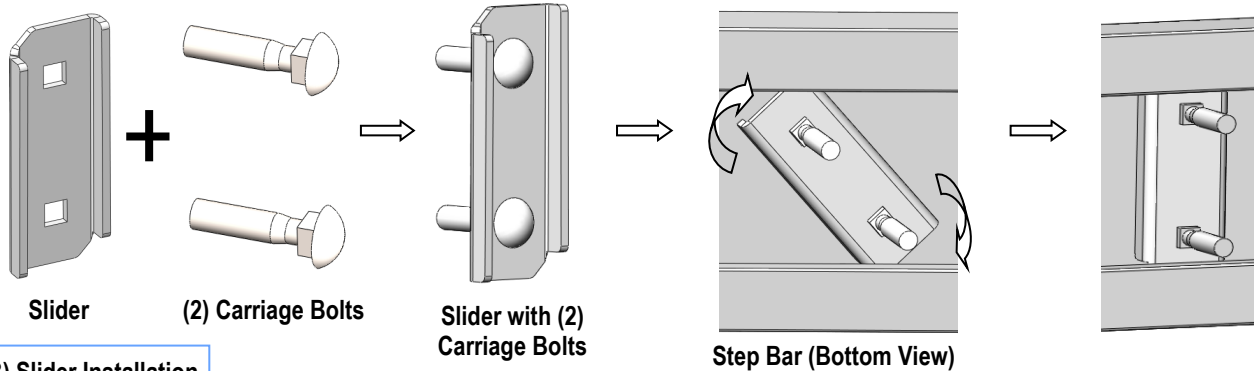

(Fig 13) Slider Installation

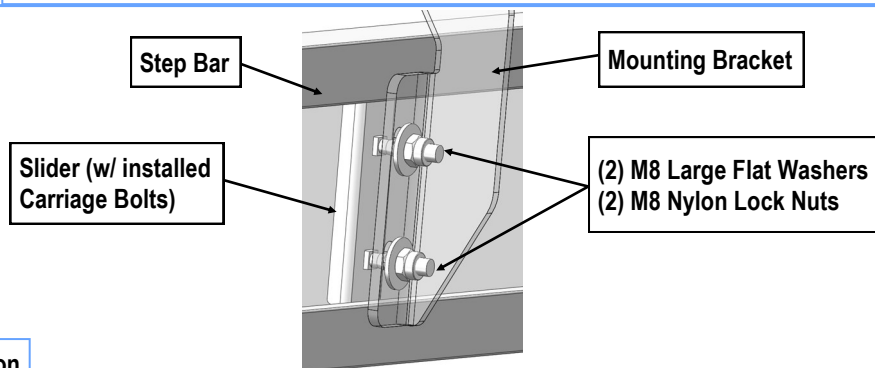

(Fig 14) Step Bar Installation