

PARTS LIST:

Item	QTY	Description	Item	QTY	Description
#1	2	Running Board(use for left or right)	#7	12	8mm Lock Washers
#2	1	Driver/Left Front Mounting Bracket (DFM)	#8	12	8mm Flat Washers
#3	1	Passenger/Right Front Mounting Bracket (PFM)	#9	12	6mm x 20mm T-Bolts
#4	2	Driver Center/Passenger Rear Mounting Bracket (DCM/PRM)	#10	12	6mm Flat Washers
#5	2	Driver Rear/Passenger Center Mounting Bracket (PCM/DRM)	#11	12	6mm Nylon Lock Nuts
#6	12	8mm x 30mm Hex Bolts			

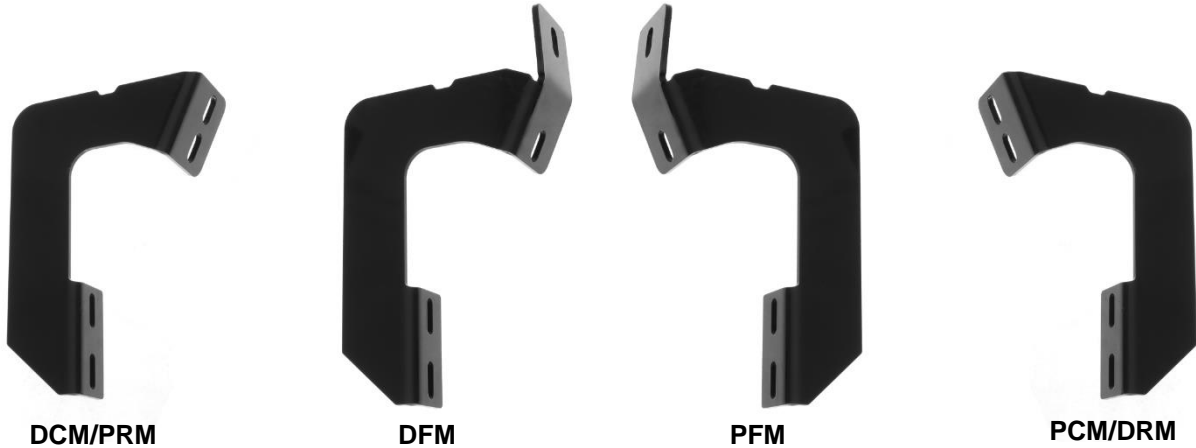

IMPORTANT ALERT: FOR WHEEL TO WHEEL APPLICATION, WEIGHT TO THE REAR END AREA OF THE RUNNING BOARD BEHIDE THE LAST BRACKET NEED TO LESS THEN 130KG.OVERWEIGHT IN THIS AREA MAYBE DAMAGE YOUR RUNNING BOARD.

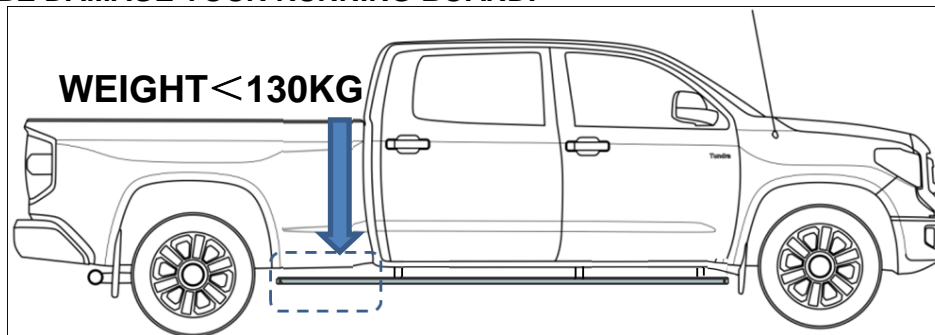

1. REMOVE CONTENTS FROM BOX. VERIFY ALL PARTS ARE PRESENT. READ INSTRUCTIONS CAREFULLY. ASSISTANCE IS RECOMMENDED.
2. Starting on the driver side front of the vehicle, remove the existing (2) factory bolts, (or plastic plugs) **(Figure 1)**. This will be the mounting location for the driver side front Mounting Bracket.
3. Select the driver side Front Bracket, **(Figure 2)**. Attach the Bracket to the vehicle using the included (2) 8mm x 30mm Hex Bolts, (2) 8mm Lock Washers and (2) 8mm Flat Washers, **(Figure 3)**. Do not tighten hardware at this time.
4. Move along the side panel to the next mounting location closest to the front Bracket, **(Figure 4)**. Repeat **Step 2 & 3** to install the driver side Center Bracket, **(Figures 5 & 6)**.
5. Next, move to the last mounting location at the back of the cab. Select the driver side Rear Bracket, **(Figure 7)**. Repeat **Steps 2 & 3** to install the rear Bracket, **(Figure 8)**.
6. Select the Running Board. Slip (12) 6mm T-Bolts into each bottom channel **(Figure 9)**. Carefully position the Running Board onto the (3) Mounting Brackets. **IMPORTANT:** Do not slide the Running Board on the Brackets or damage to the finish may result. Attach the Running Board to the Mounting Brackets with (4) 6mm T-bolts,(4)6mm flat washers and (4)6mm lock nuts **(Figure 10)**. Do not tighten hardware.
7. Level and adjust the Running Board properly and tighten all hardware.

8. Repeat **Steps 2—7** for passenger side installation. **NOTE: The Passenger Center location use the same Mounting Bracket as Drive Rear Mounting Bracket. The Passenger Rear location use the same Mounting Bracket as Drive Center Mounting Bracket.**

9. Do periodic inspections to the installation to make sure that all hardware is secure and tight.

To protect your investment, wax this product after installing. Regular waxing is recommended to add a protective layer over the finish. Do not use any type of polish or wax that may contain abrasives that could damage the finish.

For Polished Finishes: Aluminum polish may be used to polish small scratches and scuffs on the finish. Mild soap may be used also to clean the Running Board.

For black finishes: Mild soap may be used to clean the Running Board.

Driver Side Installation Pictured

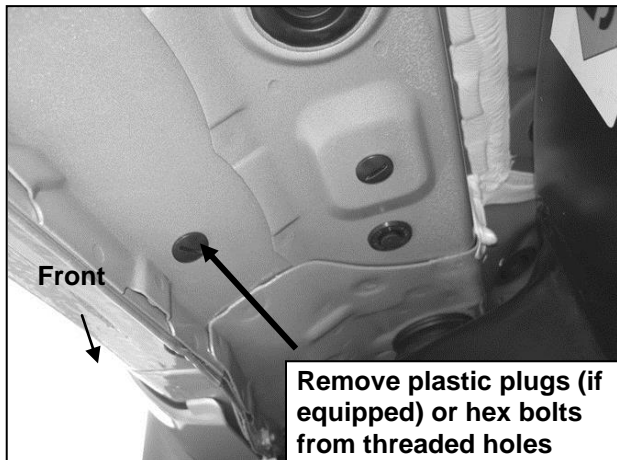

(Fig 1) Driver/Left Front Mounting Location Pictured

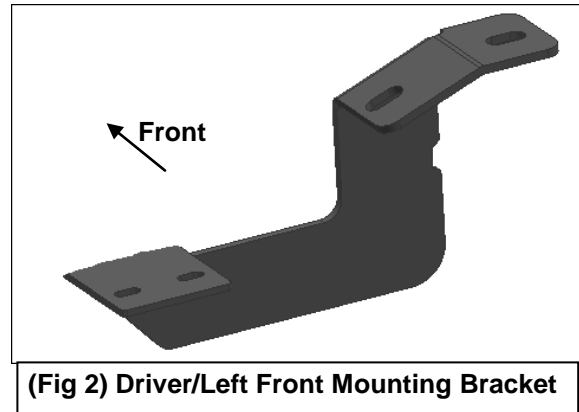

(Fig 2) Driver/Left Front Mounting Bracket

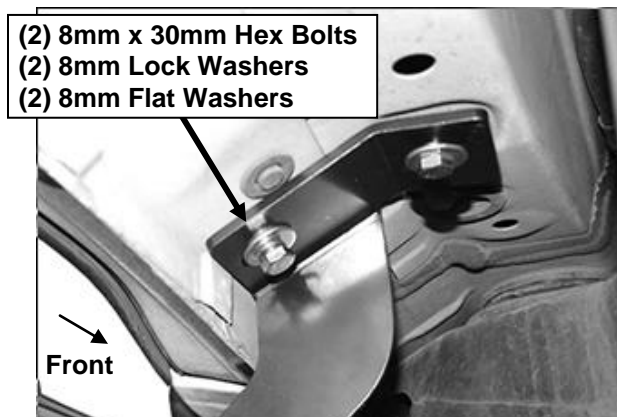

(Fig 3) Driver/Left Front Mounting Location Pictured

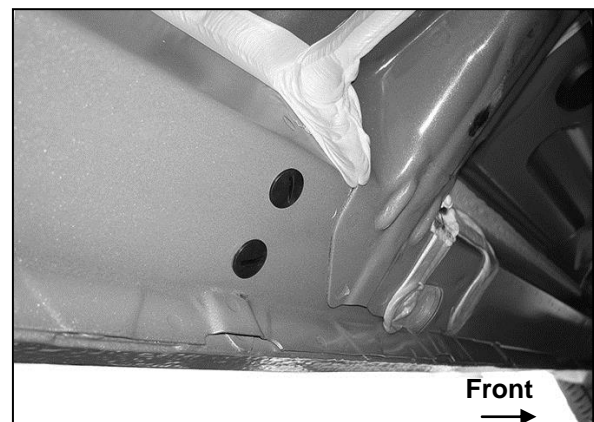

(Fig 4) Example of center and rear locations

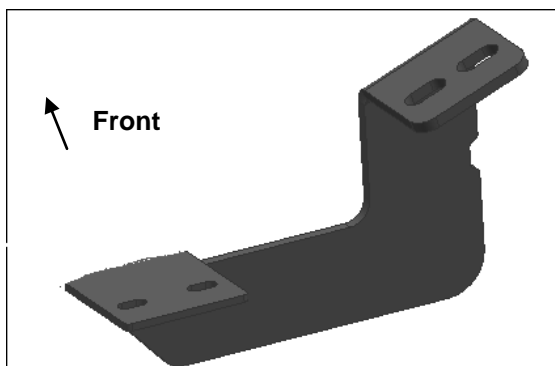

(Fig 5) Driver/Left center Bracket

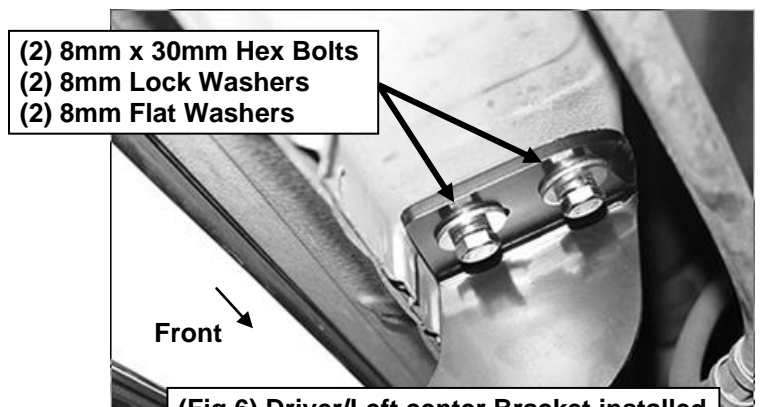

(Fig 6) Driver/Left center Bracket installed

Driver Side Installation Pictured

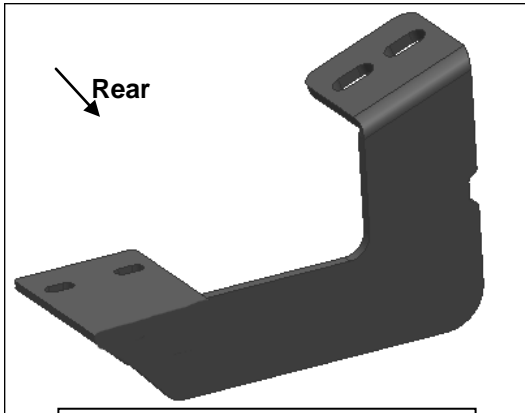

(Fig 7) Driver/Left rear Bracket

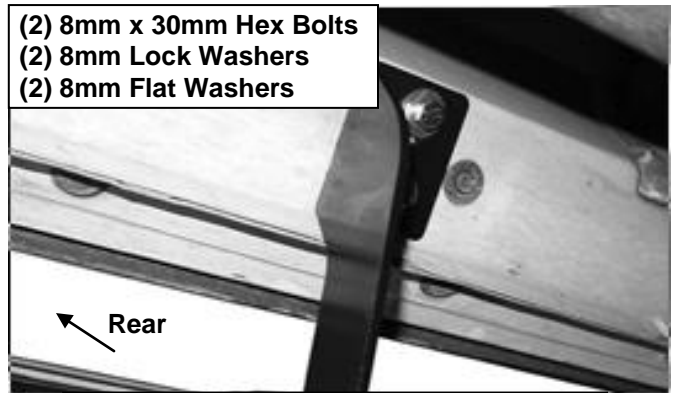

- (2) 8mm x 30mm Hex Bolts
- (2) 8mm Lock Washers
- (2) 8mm Flat Washers

(Fig 8) Driver/Left Rear Bracket Pictured

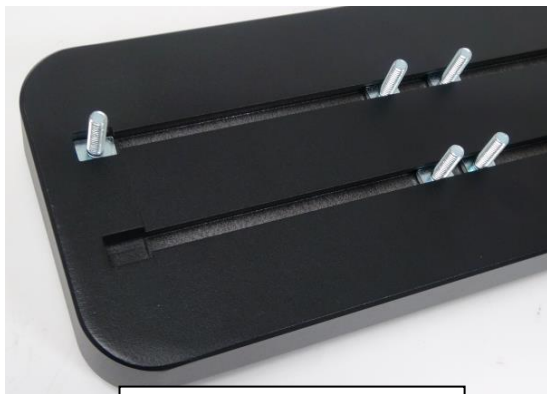

(Fig 9) Slip 6mm T-bolts into the bottom channel

- (4)6mmT-bolts
- (4)6mm Flat Washers
- (4)6mmLock nuts

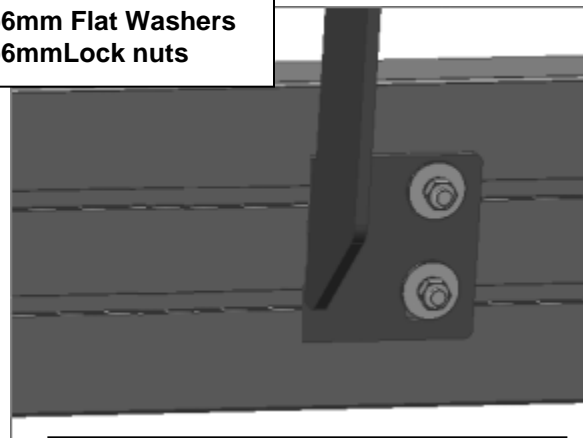

(Fig 10) Drive side Bracket installation