

# iBoard®

## iBoard® by APS

PART#: IB-R060

READ INSTRUCTIONS CAREFULLY BEFORE STARTING INSTALLATION. REMOVE CONTENTS FROM BOX AND VERIFY ALL PARTS ARE PRESENT. ASSISTANCE IS RECOMMENDED.

\*ROCKER PANEL MOUNT  
\*DRILLING IS REQUIRED

Fastener Size	Tightening Torque (ft-lbs)	Required
6mm	6-7	√
8mm	16-18	√
10mm	31-32	X
12mm	56-58	X
14mm	92-94	X

Item	QTY	Description	Item	QTY	Description
1#	2	Driver / Passenger Front Mounting Brackets	6#	16	ST6.3-25mm Hex Flange Self Tapping Screws
2#	6	Mounting Brackets	7#	16	M6X1-20mm Square Head Bolts
3#	8	M8X1.25-20mm Hex Bolts	8#	16	M6 Large Flat Washers
4#	16	M8 Flat Washers	9#	16	M6X1 Nylon Lock Nuts
5#	8	M8X1.25 Nylon Lock Nuts			

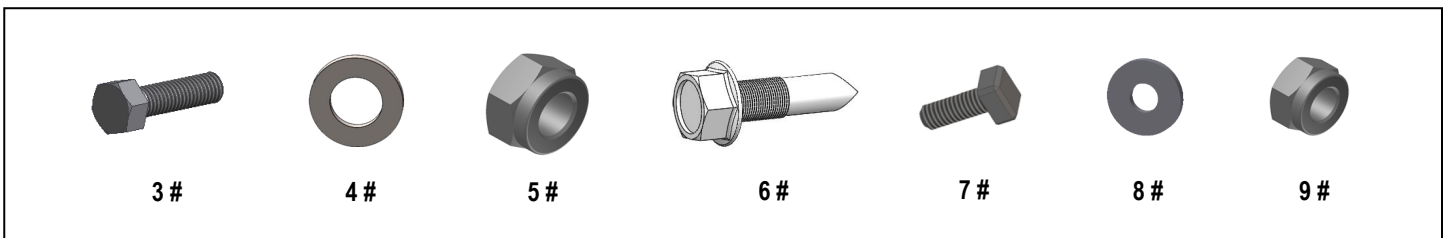

# iBoard®

Driver

Front

Passenger

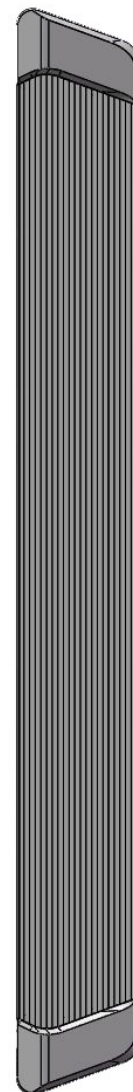
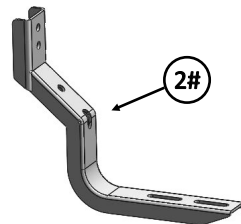
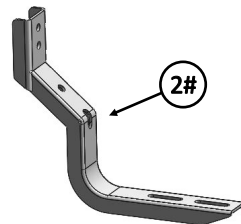
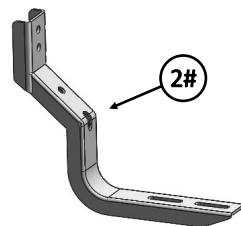
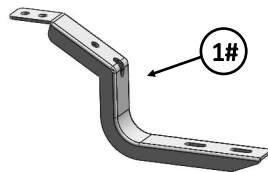
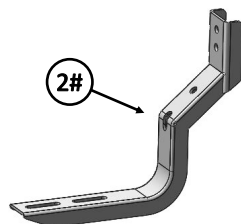
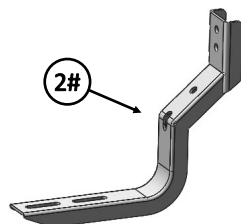
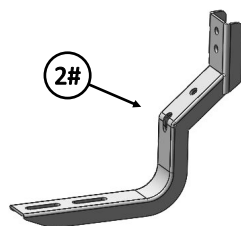
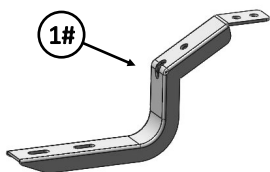
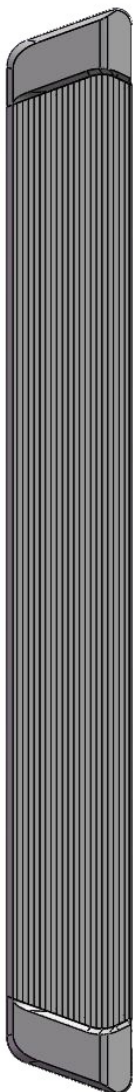

# iBoard®

## STEP 1

Start installation from the passenger side of the vehicle. Drilling 5/16" holes in pinch weld and rocker panel as show, (See Fig 1).

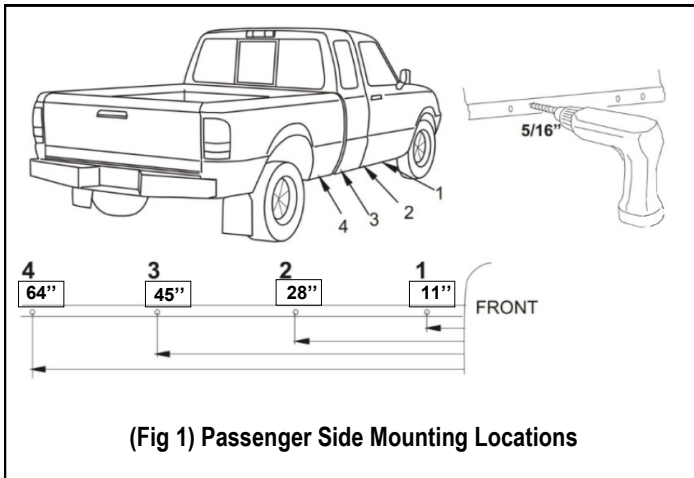

## STEP 2

Start from the passenger side front mounting location. Select (1) Passenger Front Mounting Bracket. Attach the Passenger Front Mounting Bracket with (2) ST6.3-25mm Hex Flange Self Tapping Screws, (1) M8X1.25-20mm Hex Bolt, (2) M8 Flat Washers, and (1) M8X1.25 Nylon Lock Nut, (Fig 2). Do not fully tighten hardware at this time.

**Note:** (2) Driver/Passenger Front Mounting Brackets are universal.

## STEP 3

Move to the passenger side 2nd, 3rd & 4th mounting locations. Select the Mounting Brackets, repeat **Step 2** to install the Mounting Brackets, (Fig 3). Do not fully tighten hardware at this time.

**Note:** (6) Mounting Brackets are universal.

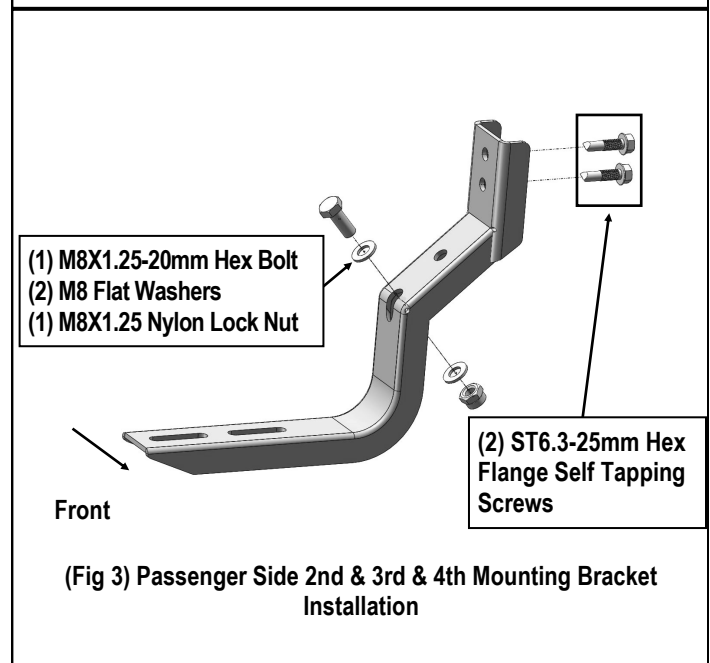
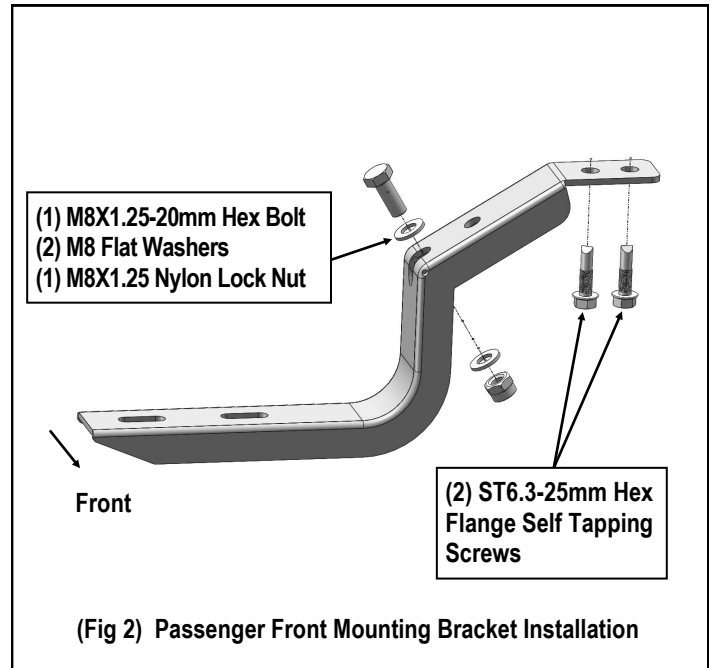

# iBoard®

## STEP 4

Select a Running Board. Slip (4) M6X1-20mm Square Head Bolts into each bottom channel (**Fig 4**). Carefully position the Running Board onto the (4) Mounting Brackets.

**IMPORTANT:** Do not slide the Running Board on the Brackets or the bottom surface of the board will be damaged. Attach the Running Board to each Mounting Brackets with (2) M6x1-20mm Square Head Bolts, (2) M6 Large Flat Washers and (2) M6X1 Nylon Lock Nuts (**Fig 5**). Do not fully tighten at this time.

M6X1-20mm Square Head Bolts

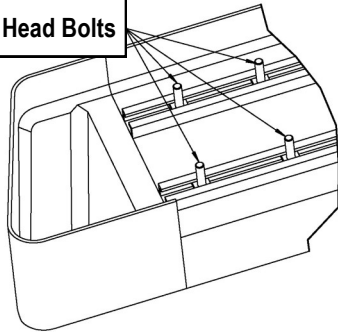

(Fig 4) Slip M6X1-20mm Square Head Bolts Into The Bottom Channels

(2) M6X1-20mm Square Head Bolts  
(2) M6 Large Flat Washers  
(2) M6X1 Nylon Lock Nuts

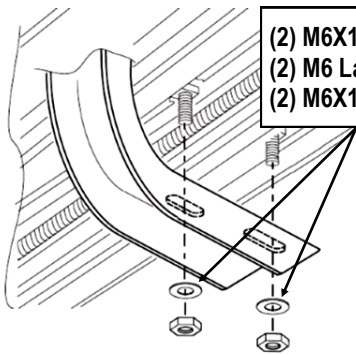

(Fig 5) Running Board Installed Onto Mounting Bracket

## STEP 5

Level and adjust the Running Board and fully tighten all hardware.

**Important:** Please follow the recommended Tightening Torques shown in the table on page 1. Don't over tighten, or the nuts/bolts will be damaged.

## STEP 6

Repeat **Steps 1-5** for the other side Running Board installation. The installation is completed.

### Attention

Do periodic inspections to the installation to make sure that all hardware is secure and tight.

In order to protect your bars/boards, please use only mild soap/non-abrasive products for cleaning.