

# iBoard®



Scan for  
Installation Video

## iBoard® by APS

PART#: IB-R974

READ INSTRUCTIONS CAREFULLY BEFORE STARTING INSTALLATION. REMOVE CONTENTS FROM BOX AND VERIFY ALL PARTS ARE PRESENT. ASSISTANCE IS RECOMMENDED.

\*ROCKER PANEL MOUNT  
\*NO DRILLING REQUIRED

Fastener Size	Tightening Torque (ft-lbs)	Required
6mm	6-7	√
8mm	16-18	√
10mm	31-32	X
12mm	56-58	X
14mm	92-94	X

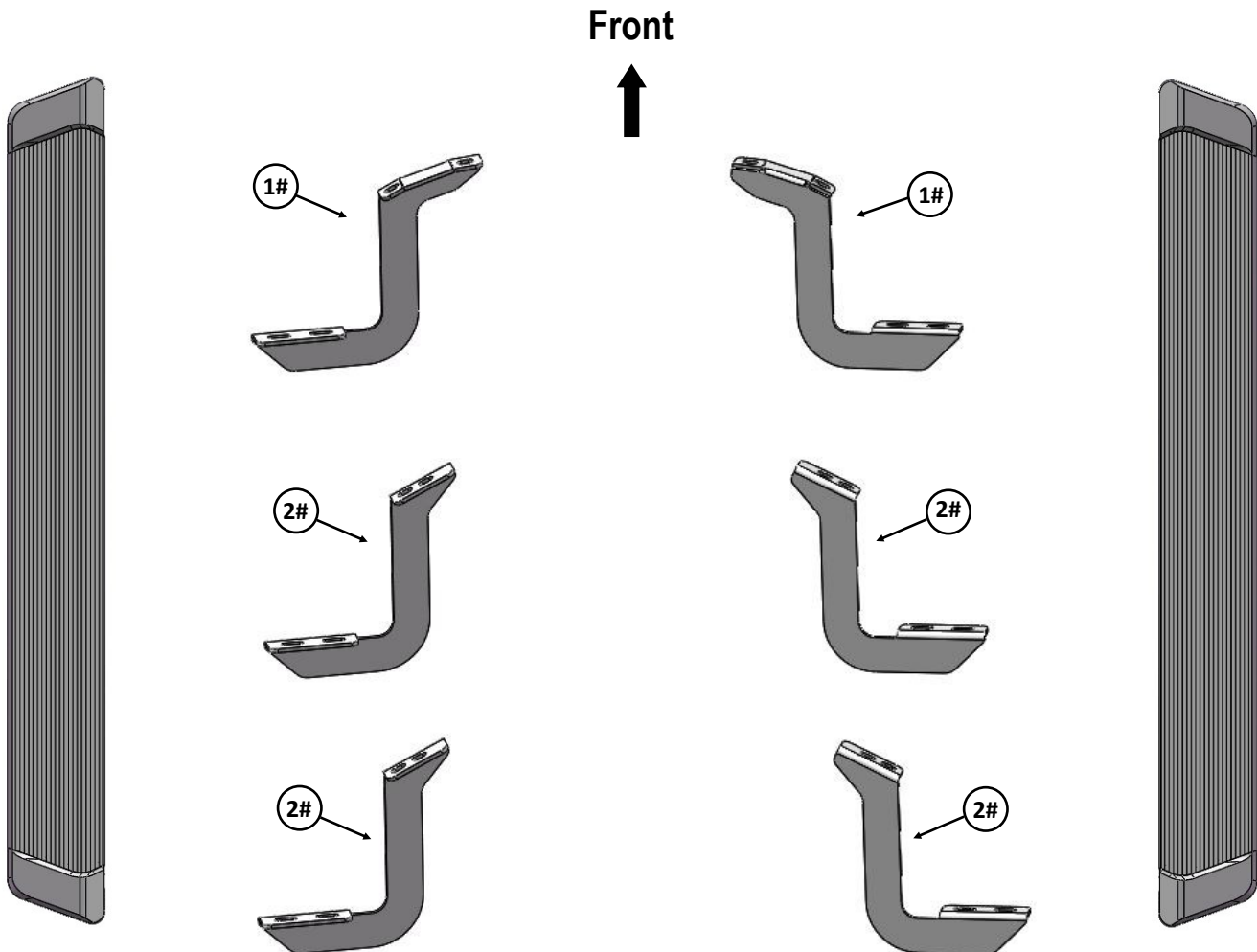

Customer Support: [info@iboardauto.com](mailto:info@iboardauto.com)



Hardware Package A (For Bracket Installation)					
Item	QTY	Description	Item	QTY	Description
1#	2	Driver / Passenger Front Mounting Brackets	4#	12	M8 Large Flat Washers
2#	4	Mounting Brackets	5#	12	M8 Lock Washers
3#	12	M8X1.25-30mm Hex Bolts			

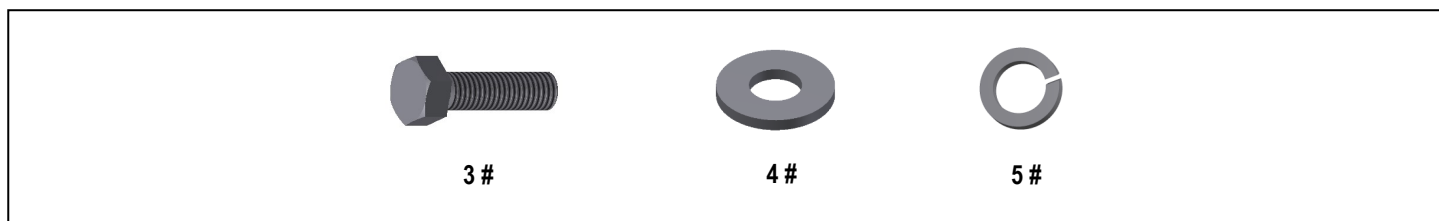

Hardware Package B (For Step Bar Installation)					
Item	QTY	Description	Item	QTY	Description
1#	12	M6X1-20mm Square Head Bolts	3#	12	M6 Nylon Lock Nuts
2#	12	M6 Large Flat Washers			

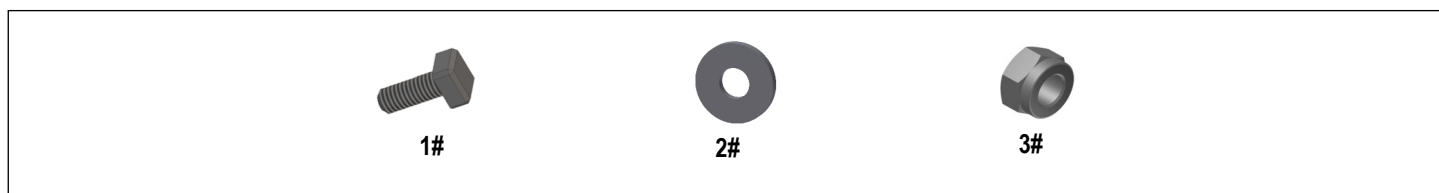



## STEP 1

Start installation from the Passenger side of the vehicle, remove the existing (2) factory bolts on the mounting locations on rocker panel, (Figs 1 & 2).

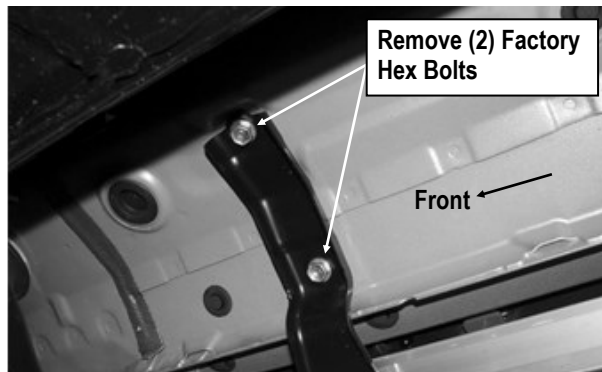

(Fig 1) Passenger Side Front Mounting Location

Remove (2) Factory  
Hex Bolts

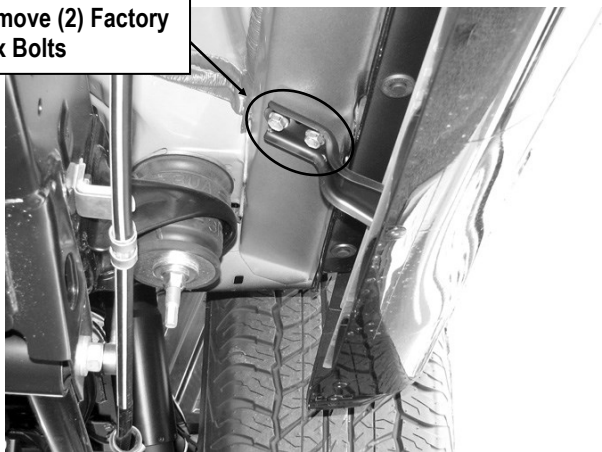

(Fig 2) Passenger Side Rear Mounting Location

## STEP 2

Select (1) Passenger Front Mounting Bracket. Attach the bracket over the factory bracket with (2) M8x1.25-30mm Hex Bolts, (2) M8 Large Flat Washers and (2) M8 Lock Washers (Fig 3). Do not fully tighten hardware at this time.

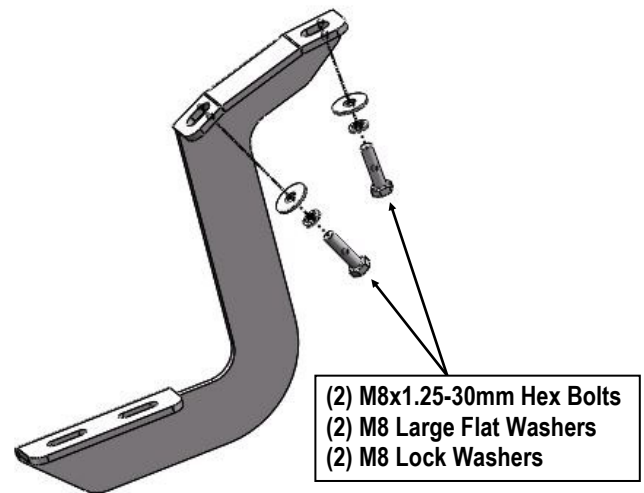
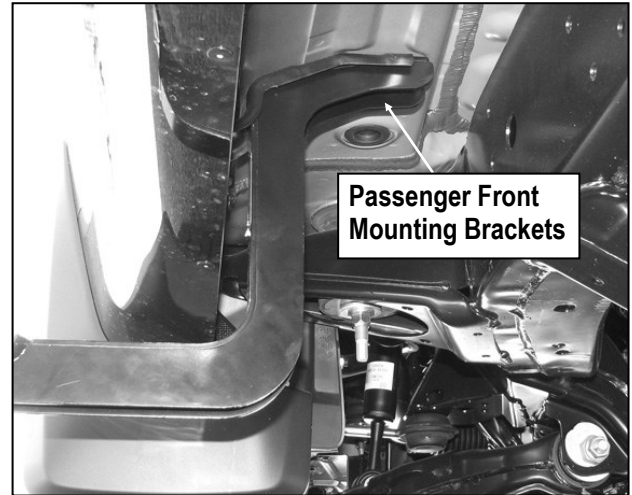

(Fig 3) Passenger Front Mounting Bracket Installed

## STEP 3

Move to center & rear mounting locations. Repeat **Steps 1-2** to install the Passenger Center & Rear Mounting Brackets.

**Note: Passenger Center & Rear Mounting Bracket are universal .**



## STEP 4

Once all (3) mounting brackets are installed. Select a Running Board. Slip (3) M6X1-20mm Square Head Bolts into each bottom channel (**Fig 3**). Carefully position the Running Board onto the (3) Mounting Brackets. Attach the Running Board to each Mounting Bracket with (2) M6X1-20mm Square Head Bolts, (2) M6 Large Flat Washers and (2) M6 Nylon Lock Nuts (**Fig 4**). Do not fully tighten at this time.

**IMPORTANT:** Do not slide the Running Board on the Brackets or the bottom surface of the board will be damaged.

M6X1-20mm Square Head Bolts

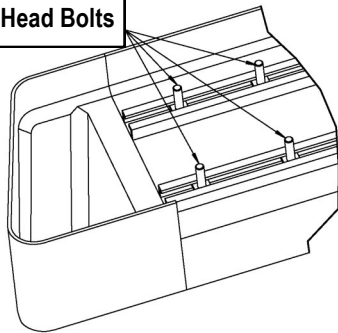

(Fig 3) Slip M6X1-20mm Square Head Bolts Into The Bottom Channels

(2) M6X1-20mm Square Head Bolts  
(2) M6 Large Flat Washers  
(2) M6 Nylon Lock Nuts

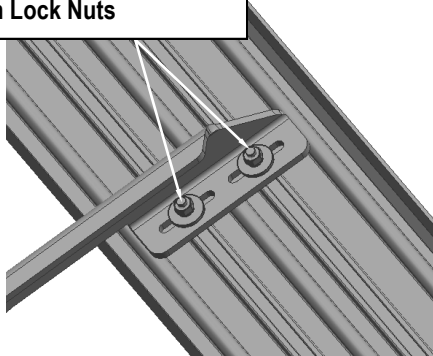

(Fig 4) Running Board Installed Onto Mounting Bracket

## STEP 5

Level and adjust the Running Board and fully tighten all hardware.

**Important:** Please follow the recommended Tightening Torques shown in the table on page 1. Don't over tighten, or the nuts/bolts will be damaged.

## STEP 6

Repeat **Steps 1-5** for the other side Running Board installation. The installation is completed .

### Attention

Do periodic inspections to the installation to make sure that all hardware is secure and tight.

In order to protect your bars/boards, please use mild soap/non-abrasive products for cleaning only.