

iBoard®



Scan for
Installation Video

iBoard® by APS

PART#: IB-R973

READ INSTRUCTIONS CAREFULLY BEFORE STARTING INSTALLATION. REMOVE CONTENTS FROM BOX AND VERIFY ALL PARTS ARE PRESENT. ASSISTANCE IS RECOMMENDED.

*ROCKER PANEL MOUNT
*NO DRILLING REQUIRED

Fastener Size	Tightening Torque (ft-lbs)	Required
6mm	6-7	√
8mm	16-18	√
10mm	31-32	X
12mm	56-58	X
14mm	92-94	X

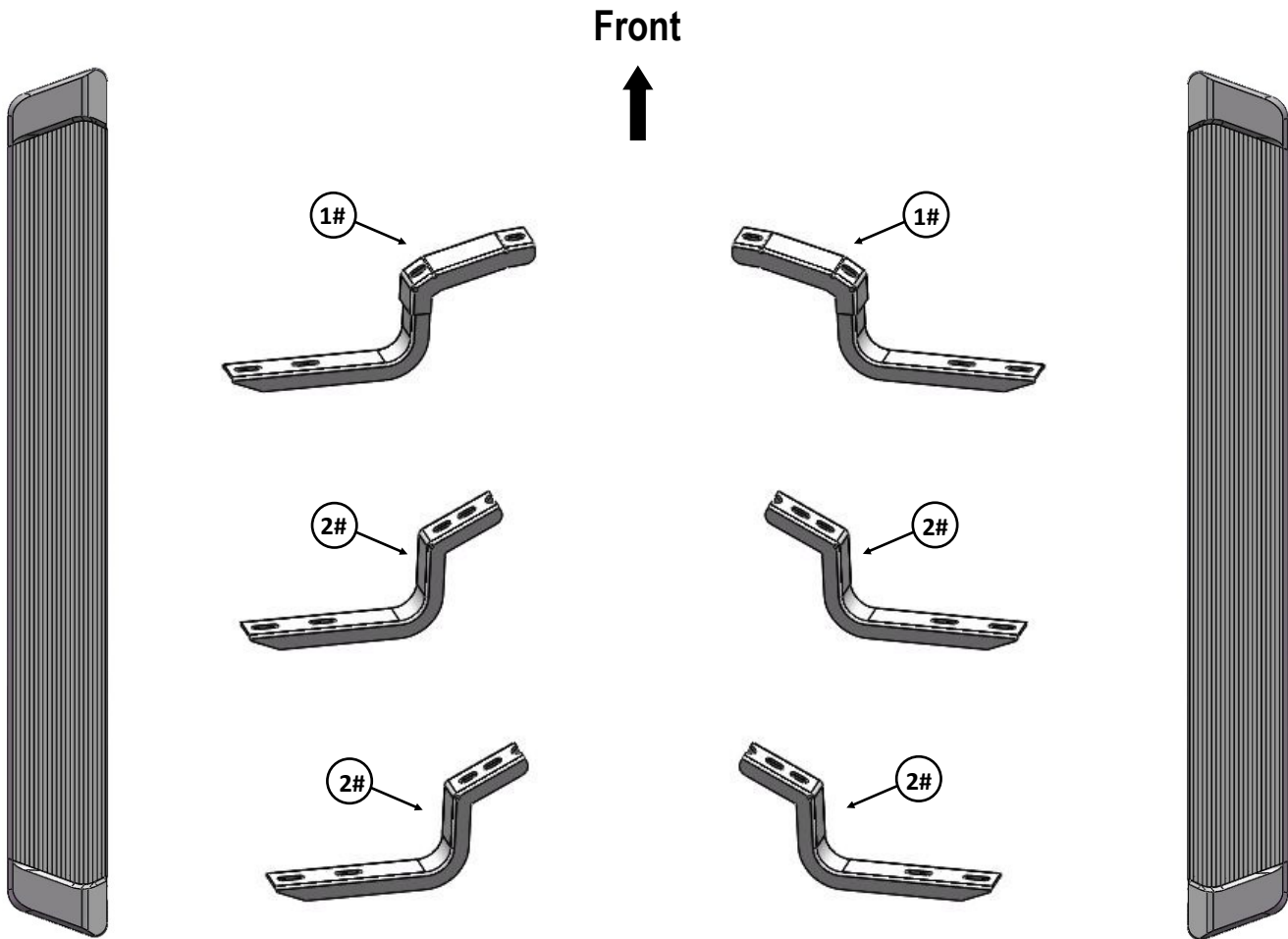

Customer Support: info@iboardauto.com



Hardware Package A (For Bracket Installation)

Item	QTY	Description	Item	QTY	Description
1#	2	Driver/Passenger Front Mounting Brackets	4#	12	M8 Flat Washers
2#	4	Mounting Brackets	5#	12	M8 Lock Washers
3#	12	M8X1.25-30mm Hex Bolts			



3 #



4 #



5 #

Hardware Package B (For Step Bar Installation)

Item	QTY	Description	Item	QTY	Description
1#	12	M6X1-20mm Square Head Bolts	3#	12	M6 Nylon Lock Nuts
2#	12	M6 Large Flat Washers			

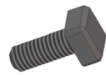

1#



2#



3#



STEP 1

Start installation from the passenger side front of the vehicle, remove the existing (2) factory bolts located by the front tire opening securing the factory rocker panel bracket to the vehicle, (Fig 1).

Remove Factory Hex Bolts

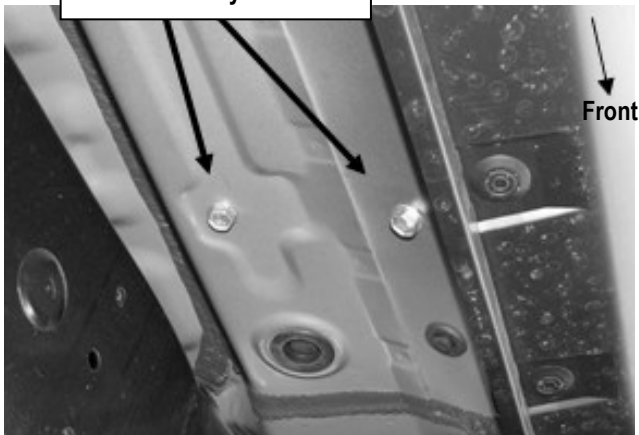

(Fig 1) Passenger Side Front Mounting Location

STEP 2

Select the Passenger Front Mounting Bracket, attach the bracket to the vehicle by using the included (2) M8x1.25-30mm Hex Bolts, (2) M8 Lock Washers and (2) M8 Flat Washers, (Fig 2). Do not fully tighten hardware at this time.

Note: Driver & Passenger Front Mounting Bracket are universal.

STEP 3

Move along the side panel to the Driver Side Center and Rear Mounting Locations, (Fig 3). Repeat **Steps 1 & 2** to install the Mounting Brackets, (Fig 4).

Note: (4) Mounting Brackets are universal.

(2) M8x1.25-30mm Hex Bolts
(2) M8 Lock Washers
(2) M8 Flat Washers

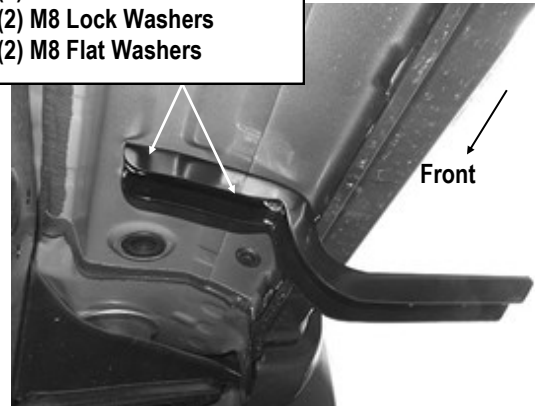

(Fig 2) Passenger Front Mounting Bracket Installed

Plastic deflector

Remove
factory
hex bolts



(Fig 3) Passenger Side Rear Mounting Location

(2) M8x1.25-30mm Hex Bolts
(2) M8 Lock Washers
(2) M8 Flat Washers

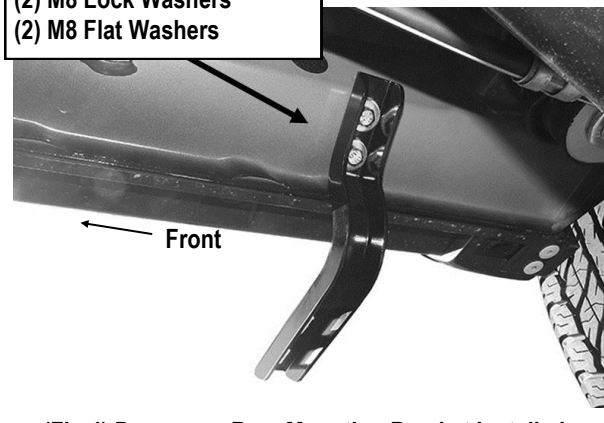

(Fig 4) Passenger Rear Mounting Bracket Installed



STEP 4

Once all (3) mounting brackets are installed. Select a Running Board. Slip (3) M6X1-20mm Square Head Bolts into each bottom channel (**Fig 5**). Carefully position the Running Board onto the (3) Mounting Brackets. Attach the Running Board to each Mounting Bracket with (2) M6X1-20mm Square Head Bolts, (2) M6 Large Flat Washers and (2) M6 X1 Nylon Lock Nuts (**Fig 6**). Do not fully tighten at this time.

IMPORTANT: Do not slide the Running Board on the Brackets or the bottom surface of the board will be damaged.

M6X1-20mm Square Head Bolts

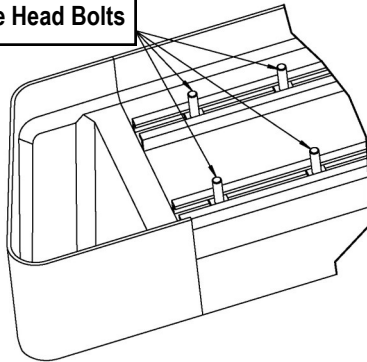

(Fig 5) Slip M6X1-20mm Square Head Bolts Into The Bottom Channels

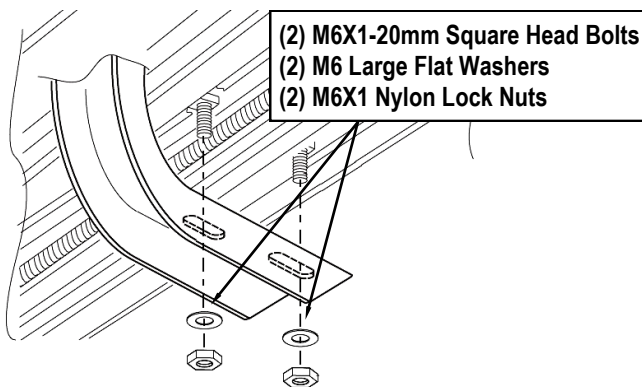

(Fig 6) Running Board Installed Onto Mounting Bracket

STEP 5

Level and adjust the Running Board and fully tighten all hardware.

Important: Please follow the recommended Tightening Torques shown in the table on page 1. Don't over tighten, or the nuts/bolts will be damaged.

STEP 6

Repeat **Steps 1-5** for the other side Running Board installation. The installation is completed .

Attention

Do periodic inspections to the installation to make sure that all hardware is secure and tight.

In order to protect your bars/boards, please use mild soap/non-abrasive products for cleaning only.