

iBoard®

iBoard® by APS

PART#: IB-R936

READ INSTRUCTIONS CAREFULLY BEFORE STARTING INSTALLATION. REMOVE CONTENTS FROM BOX AND VERIFY ALL PARTS ARE PRESENT. ASSISTANCE IS RECOMMENDED.

*ROCKER PANEL MOUNT
*NO DRILLING REQUIRED

Fastener Size	Tightening Torque (ft-lbs)	Required
6mm	6-7	√
8mm	16-18	√
10mm	31-32	X
12mm	56-58	X
14mm	92-94	X

PART LIST

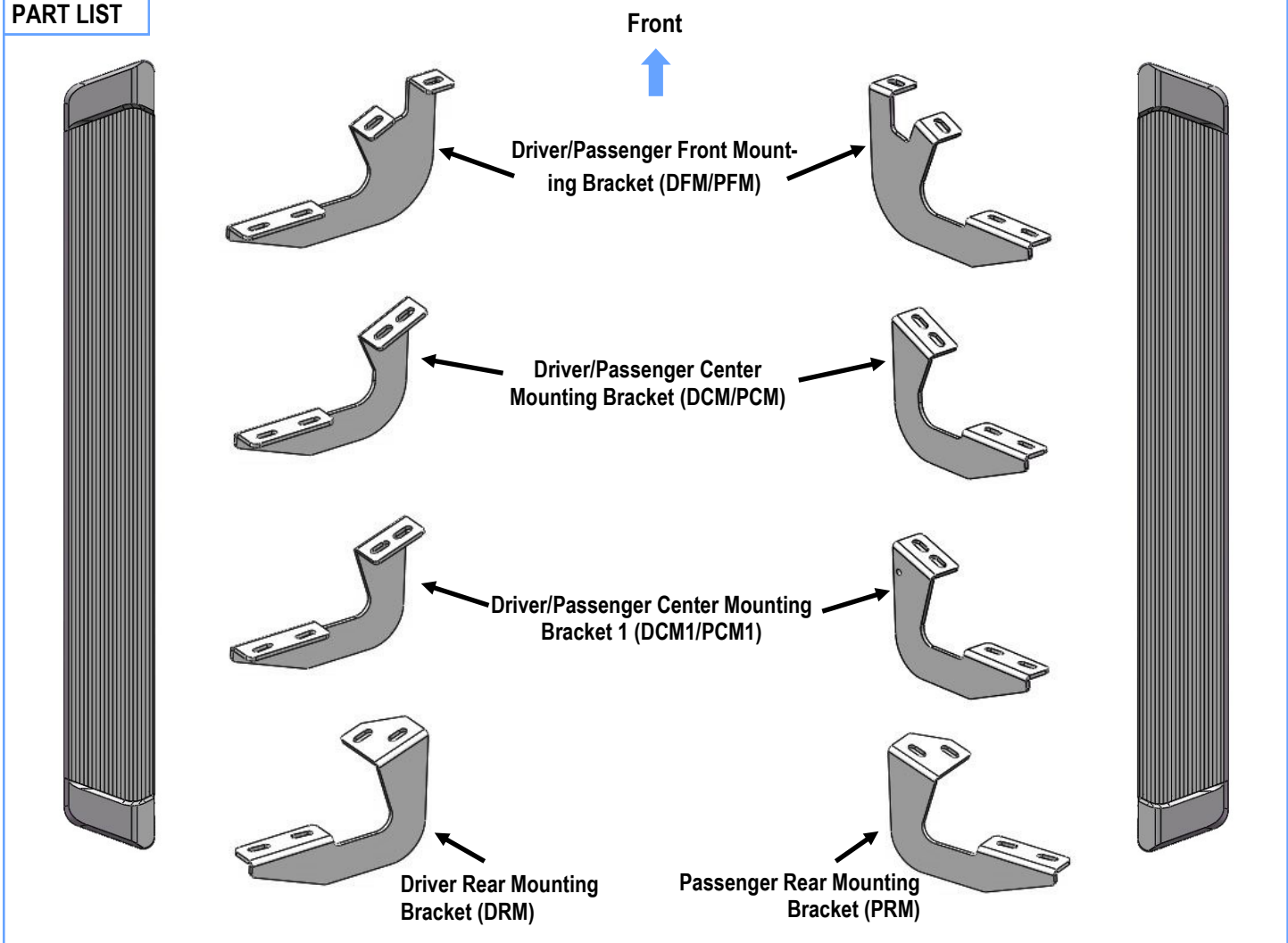

Customer Support: info@iboardauto.com

iBoard®



STEP 1

Start installation from the driver side of the vehicle. Identify the Driver Side Mounting Locations along the inner side of the rocker panel, (Fig 1). **Note:** (2) factory threaded holes on each location.

STEP 2

Attach (4) Driver Side Mounting Brackets onto the mounting locations with (2) M8X1.25-30mm Hex Bolts, (2) M8 Lock Washers and (2) M8 Large Flat Washers for each mounting bracket, (Fig 1). Do not fully tighten hardware at this time.

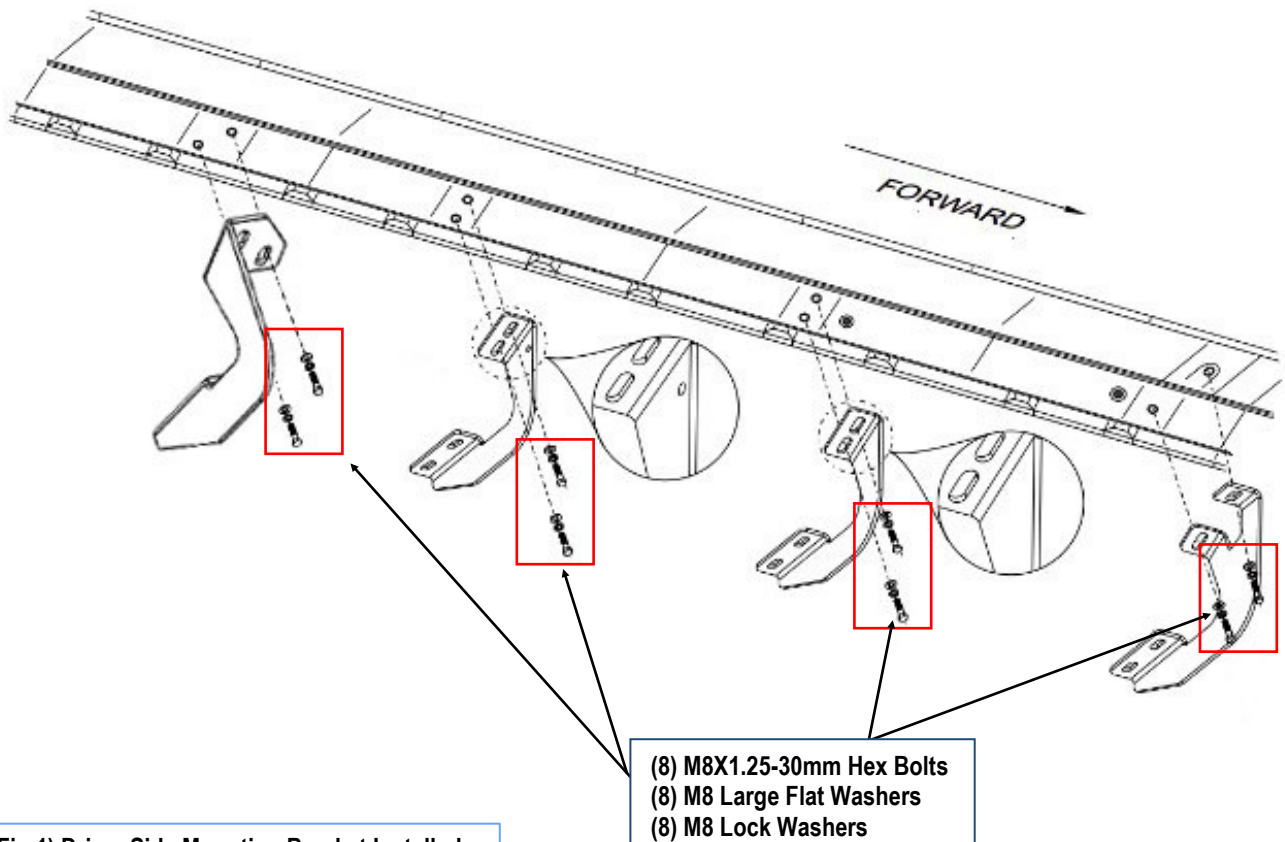

(Fig 1) Driver Side Mounting Bracket Installed

iBoard®

STEP 3

Select a Running Board. Slip (4) M6x1-20mm Square Head Bolts into each bottom channel (**Fig 2**). Carefully position the Running Board onto the (4) Mounting Brackets.

IMPORTANT: Do not slide the Running Board on the Brackets or the bottom surface of the board will be damaged. Attach the Running Board to each Mounting Bracket with (2) M6x1-20mm Square Head Bolts, (2) M6 Large Flat Washers and (2) M6 Nylon Lock Nuts (**Fig 3**). Do not fully tighten at this time.

M6X1-20mm Square Head Bolts

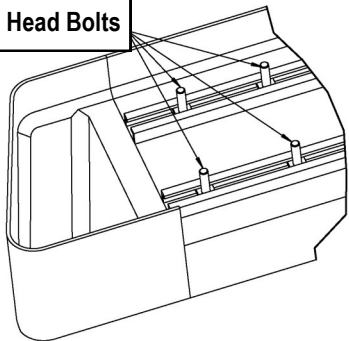

(Fig 2) Slip M6X1-20mm Square Head Bolts Into The Bottom Channels

(2) M6X1-20mm Square Head Bolts
(2) M6 Large Flat Washers
(2) M6 Nylon Lock Nuts

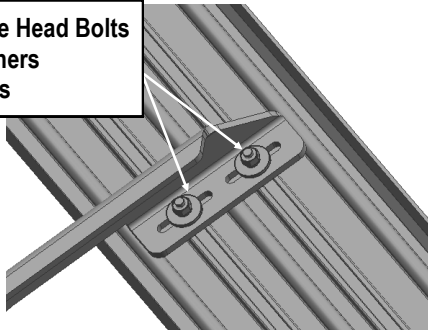

(Fig 3) Running Board Installed Onto Mounting Bracket

STEP 4

Level and adjust the Running Board and fully tighten all hardware.

Important: Please follow the recommended Tightening Torques shown in the table on page 1. Don't over tighten, or the nuts/bolts will be damaged.

STEP 5

Repeat **Steps 1-4** for the other side Running Board installation. The installation is completed.

Attention

Do periodic inspections to the installation to make sure that all hardware is secure and tight.

In order to protect your bars/boards, please use only mild soap/non-abrasive products for cleaning.