

iRunning Board Installation Instruction

Part#: IB20RIC1

**Application: For 2004-2006 Toyota Tundra Double Cab/
2001-2007 Toyota Sequoia**

Rev. 20180101

PARTS LIST:

Item	QTY	Description	Item	QTY	Description
#01	2	Driver/ Passenger Front Mounting Bracket (DFM/PFM)	#05	16	M6 T- Bolts
#02	6	Driver/Passenger Center/Rear Mounting Bracket	#06	16	M6 Flat Washers
#03	2	M8 x1.25- 30mm Flange Hex Bolts	#07	16	M6 Nylon Lock Nuts
#04	6	M8 x1.25 Flange Nuts	#08	2	Step Board (Used for left and right)



INSTALLATION INSTRUCTION:

- 1. REMOVE CONTENTS FROM BOX. VERIFY ALL PARTS ARE PRESENT. READ INSTRUCTIONS CAREFULLY BEFORE STARTING INSTALLATION.**
- 2. Remove existing bolts as shown (See Figure 1).**
- 3. Attach mounting brackets as shown (See Figure 2, 3 and 4).**
- 4. Insert square head bolts as shown (4 per slot, 8 per Step board/Running board(See Figure 5).**
- 5. Attach Step board/Running board to brackets as shown(See Figure 6).**
- 6. Level and adjust the Running Board and fully tighten all hardware.**
- 7. Repeat Steps 2 - 6 for the other side Running Board installation. INSTALLATION IS COMPLETED!**
- 8. Do periodic inspections to the installation to make sure that all hardware is secure and tight.**

To protect your investment, wax this product after installing. Regular waxing is recommended to add a protective layer over the finish. Do not use any type of polish or wax that may contain abrasives that could damage the finish.

For Polished Finishes: Aluminum polish may be used to polish small scratches and scuffs on the finish. Mild soap may be used also to clean the Running Board.

For Black Finishes: Mild soap may be used to clean the Running Board.

iRunning Board Installation Instruction

Part#: IB20RIC1

Application: For 2004-2006 Toyota Tundra Double Cab/
2001-2007 Toyota Sequoia

Rev. 20180101

Driver/Passenger Side Installation Pictured

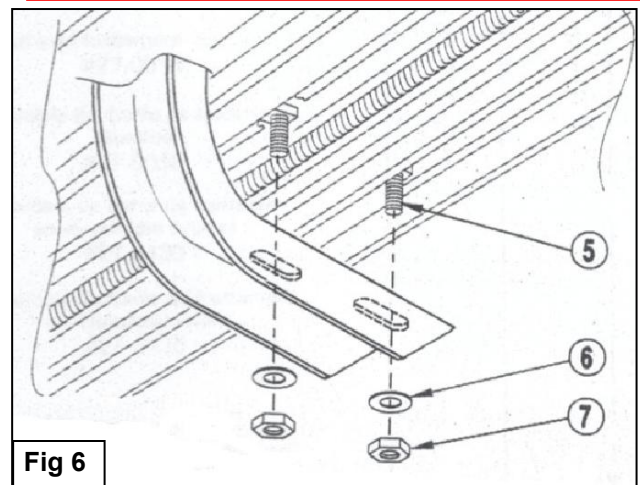
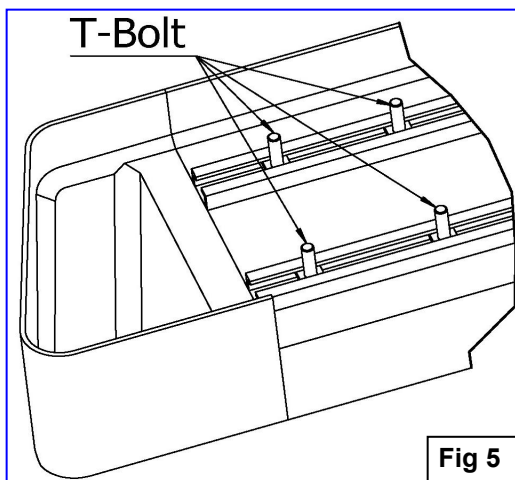
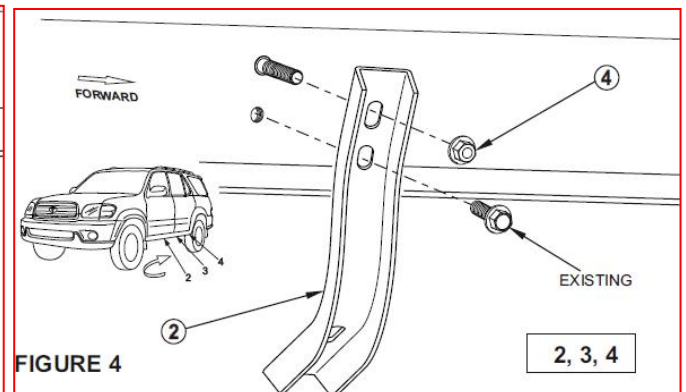
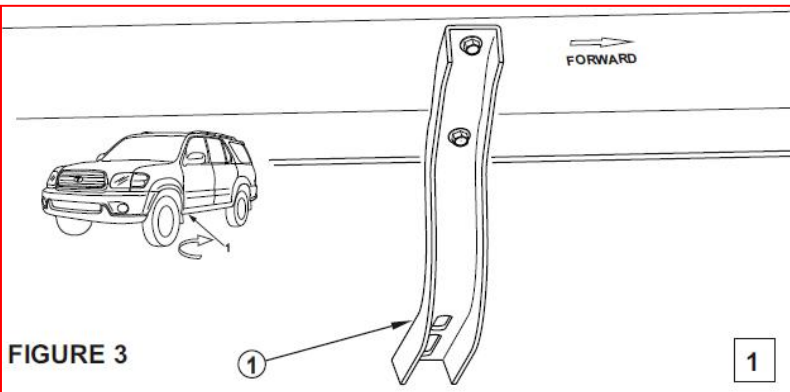
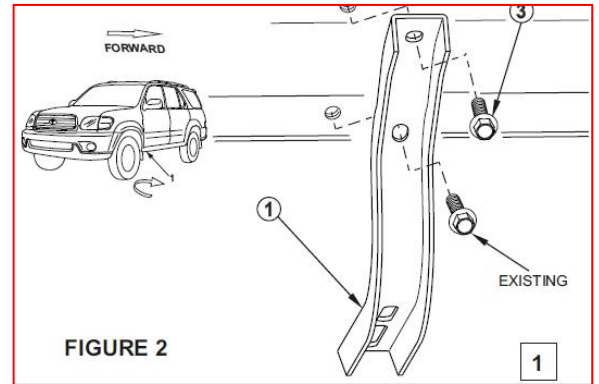
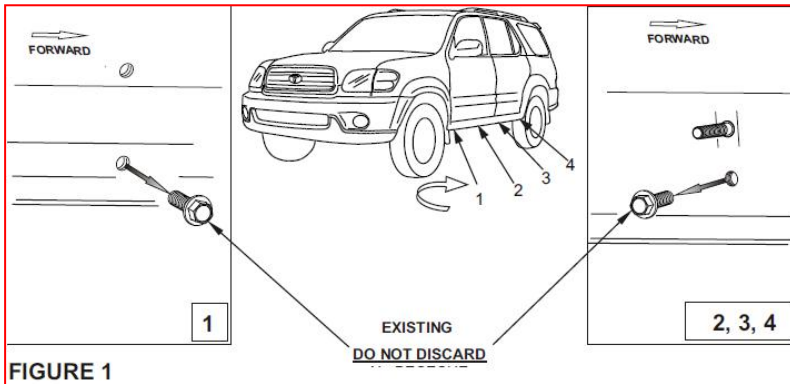

INSTALLATION IS COMPLETE!