



Scan for
Installation Video

PART#: IB-P060Y&H

iBoard® Series

READ INSTRUCTIONS CAREFULLY BEFORE START ING INSTALLATION. REMOVE CONTENTS FROM BOX AND VERIFY ALL PARTS ARE PRESENT. ASSISTANCE IS RECOMMENDED.

*ROCKER PANEL MOUNT
*DRILLING IS REQUIRED

| Fastener Size | Tightening Torque (ft-lbs) | Required |
|---------------|----------------------------|----------|
| 6mm | 6-7 | √ |
| 8mm | 16-18 | √ |
| 10mm | 31-32 | X |
| 12mm | 56-58 | X |
| 14mm | 92-94 | X |

PART LIST

Driver Side Step Bar

Front

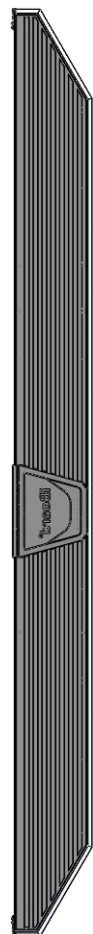
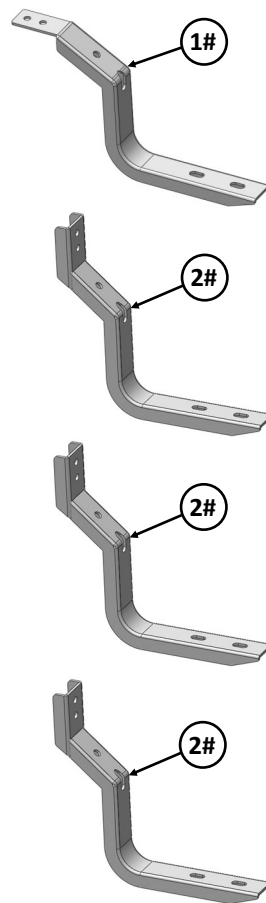
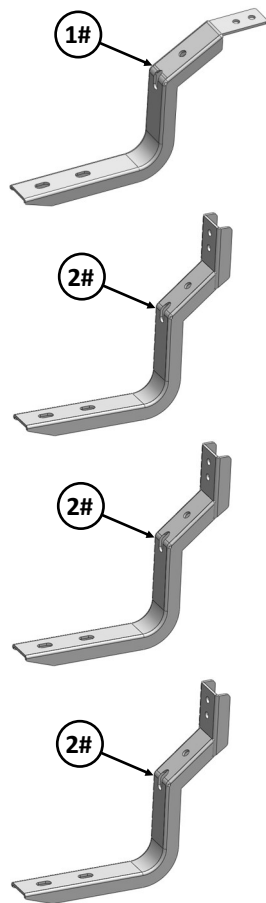

Passenger Side Step Bar







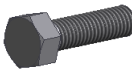

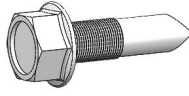
Scan for
Installation Video

| Hardware Package A (For Bracket Installation) | | | | | |
|---|-----|--|------|-----|---|
| Item | QTY | Description | Item | QTY | Description |
| 1# | 2 | Driver / Passenger Front Mounting Brackets | 4# | 16 | M8 Flat Washers |
| 2# | 6 | Mounting Brackets | 5# | 8 | M8X1.25 Nylon Lock Nuts |
| 3# | 8 | M8X1.25-20mm Hex Bolts | 6# | 16 | ST6.3-25mm Hex Flange Self Tapping Screws |

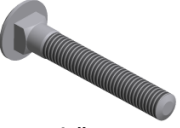
| | | | |
|---|---|---|---|
|  |  |  |  |
| 3 # | 4 # | 5 # | 6 # |

| Hardware Package B (For Step Bar Installation) | | | | | |
|--|-----|-----------------------------|------|-----|---|
| Item | QTY | Description | Item | QTY | Description |
| 1# | 16 | M8X1.25-35mm Carriage Bolts | 3# | 16 | M8 Nylon Lock Nuts |
| 2# | 16 | M8 Large Flat Washers | 4# | 8 | Sliders (Packed with Mounting Brackets) |

| | | | |
|---|---|---|---|
|  |  |  |  |
| 1 # | 2 # | 3 # | 4 # |



STEP 1

Start installation from the passenger side of the vehicle. Drilling 5/16" holes in pinch weld and rocker panel as show, (**See Fig 1**).

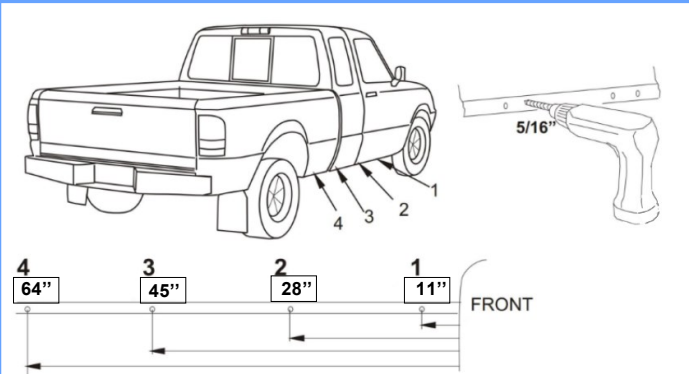

(Fig 1) Passenger Side Mounting Locations

STEP 2

Start from the passenger side front mounting location. Select (1) Passenger Front Mounting Bracket. Attach the Passenger Front Mounting Bracket with (2) ST6.3-25mm Hex Flange Self Tapping Screws, (1) M8X1.25-20mm Hex Bolt, (2) M8 Flat Washers, and (1) M8X1.25 Nylon Lock Nut, (**Fig 2**). Do not fully tighten hardware at this time.

Note: (2) Driver/Passenger Front Mounting Brackets are universal.

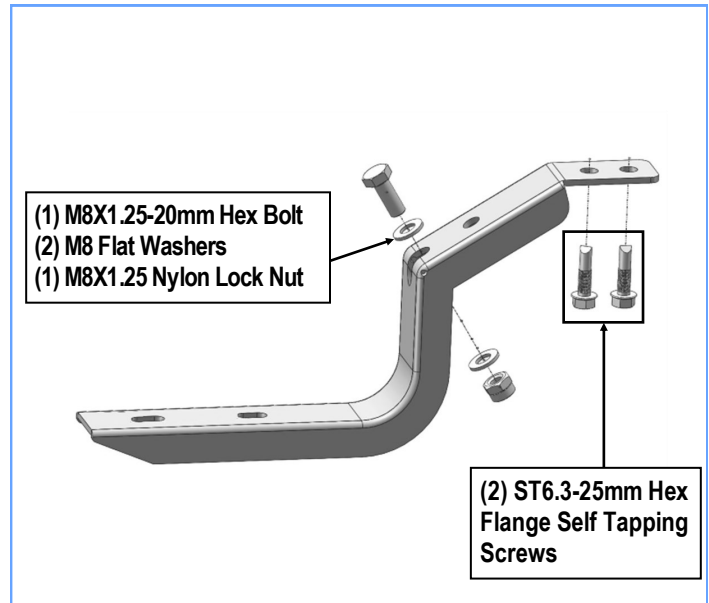

(Fig 2) Passenger Front Mounting Bracket Installation

STEP 3

Move to the passenger side 2nd, 3rd & 4th mounting locations. Select the Mounting Brackets, repeat **Step 2** to install the Mounting Brackets, (**Fig 3**). Do not fully tighten hardware at this time.

Note: (6) Mounting Brackets are universal.

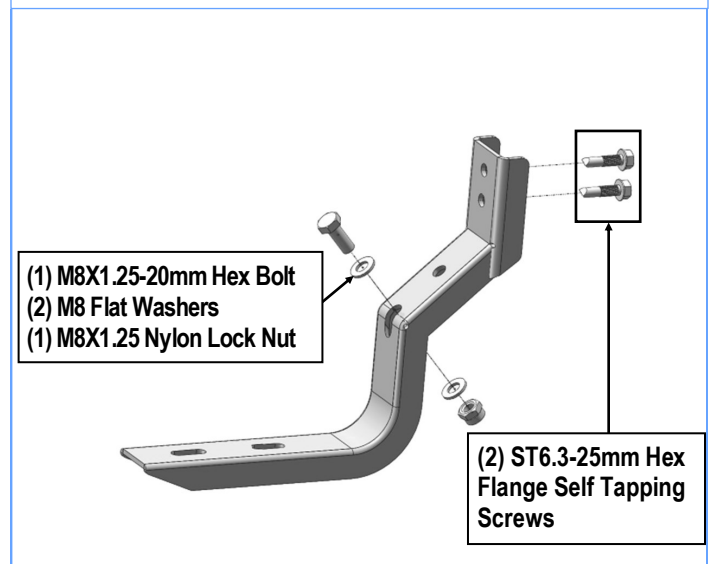

(Fig 3) Passenger Side 2nd & 3rd & 4th Mounting Bracket Installation



STEP 4

Once all (4) Passenger side mounting brackets are installed, then proceed to the Step Bar installation. **(Figs 4 & 5)**

- (1) Select (1) Slider and (2) M8X1.25-35mm Carriage Bolts;
- (2) Install (2) M8X1.25-35mm Carriage Bolts in (1) Slider.
- (3) Slide the Slider (with carriage bolts) to the **Step Bar**.
- (4) Repeat to install the other (3) sliders to the step bar.
- (5) Attach the Step Bar (with the Sliders) onto the installed mounting brackets. Position the Sliders to the installed brackets. Secure the Step Bar to the installed Brackets by using (8) M8 Large Flat Washers and (8) M8 Nylon Lock Nuts and (4) Sliders, **(Fig 5)**. Do not fully tighten hardware at this time.

Note: The Sliders are packed with the Mounting Brackets.

Level and adjust the Step Bar and fully tighten all hardware.

Repeat **Steps 1-4** for the other side Step Bar installation. **The installation is completed!!!**

Attention

Do periodic inspections to the installation to make sure that all hardware is secure and tight.

In order to protect your bars/boards, please use mild soap/non-abrasive products for cleaning only.

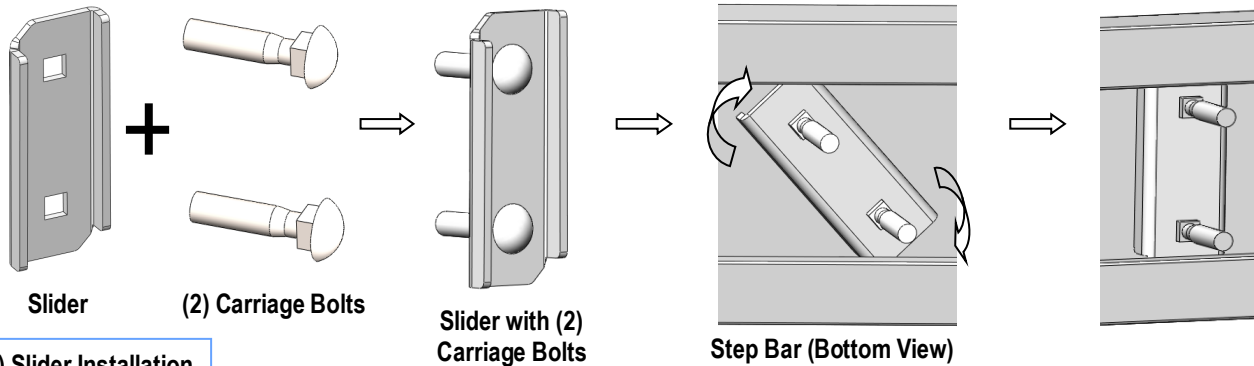

(Fig 4) Slider Installation

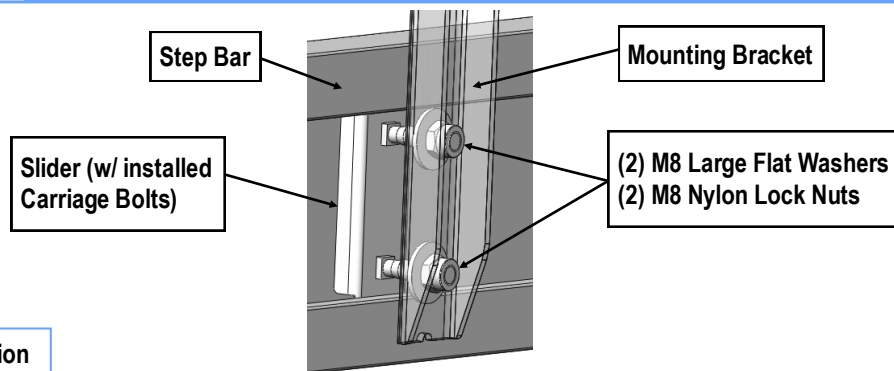

(Fig 5) Step Bar Installation