

iBoard®



Scan for
Installation Video

iBoard® by APS

PART#: IB-097/098C&H

READ INSTRUCTIONS CAREFULLY BEFORE STARTING INSTALLATION. REMOVE CONTENTS FROM BOX AND VERIFY ALL PARTS ARE PRESENT. ASSISTANCE IS RECOMMENDED.

*ROCKER PANEL MOUNT
*NO DRILLING REQUIRED

Fastener Size	Tightening Torque (ft-lbs)	Required
6mm	6-7	X
8mm	16-18	√
10mm	31-32	X
12mm	56-58	X
14mm	92-94	X

PART LIST

Driver Side Step Bar

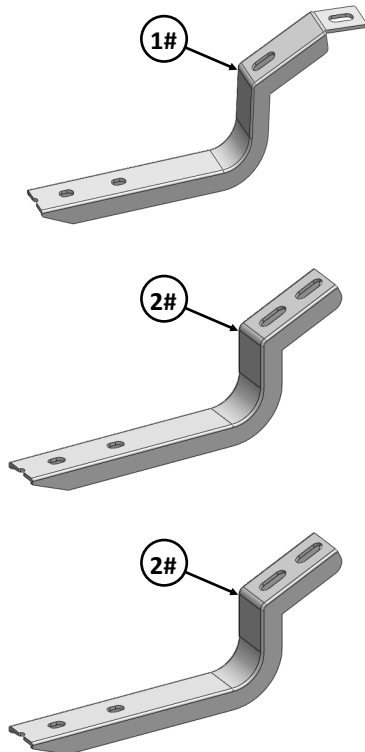

Front



Passenger Side Step Bar

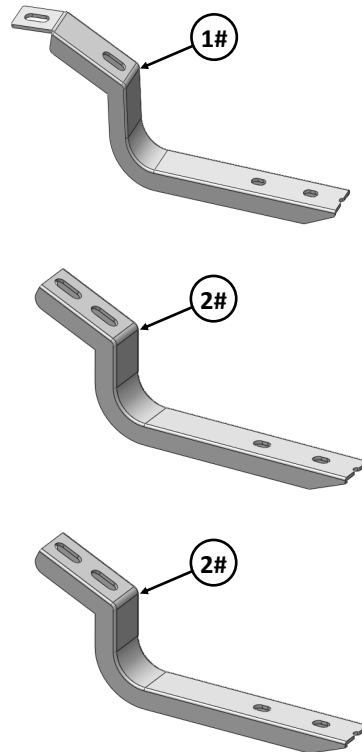

Customer Support: info@iboardauto.com



Mounting Bracket List					
Item	QTY	Description	Item	QTY	Description
1#	2	Driver/Passenger Front Mounting Brackets	2#	4	Mounting Brackets

Hardware Package A (For Bracket Installation)					
Item	QTY	Description	Item	QTY	Description
1#	12	M8X1.25-30mm Hex Bolts	3#	12	M8 Lock Washers
2#	12	M8 Flat Washers			



1 #



2 #



3 #

Hardware Package B (For Stainless Steel Step Bar Installation)					
Item	QTY	Description	Item	QTY	Description
1#	12	M8X1.25-35mm Carriage Bolts	3#	12	M8 Nylon Lock Nuts
2#	12	M8 Large Flat Washers	4#	6	Sliders (Packed with Step Bars)

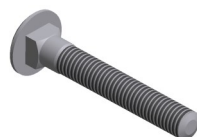

1 #



2 #



3 #



4 #



STEP 1

Starting on the driver side front of the vehicle, remove the existing (2) factory bolts, (or plastic plugs), on the side panel located by the front tire opening, (**Fig 1**). This will be the mounting location for the driver side front Mounting Bracket.

Note: There are 4 sets of threaded holes in the side panel. Starting from the front of the vehicle, use the 1st, 2nd, and 4th set of holes.

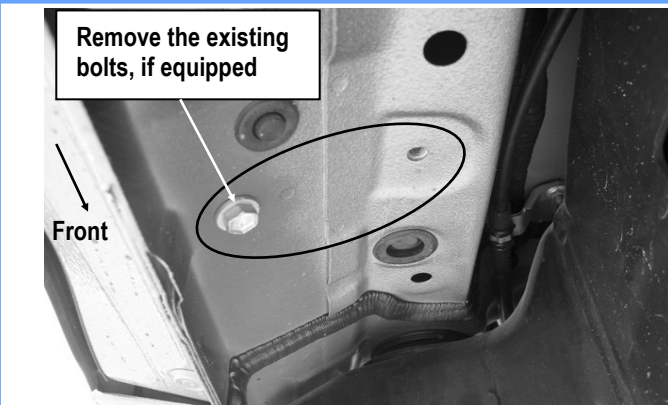

(Fig 1) Driver Side Front Mounting Location

STEP 2

Select the Driver Front Mounting Bracket. Attach the Bracket to the vehicle using the included (2) M8X1.25-30mm Hex Bolts, (2) M8 Flat Washers and (2) M8 Lock Washers. Don't tighten at this time, (**Fig 2**).

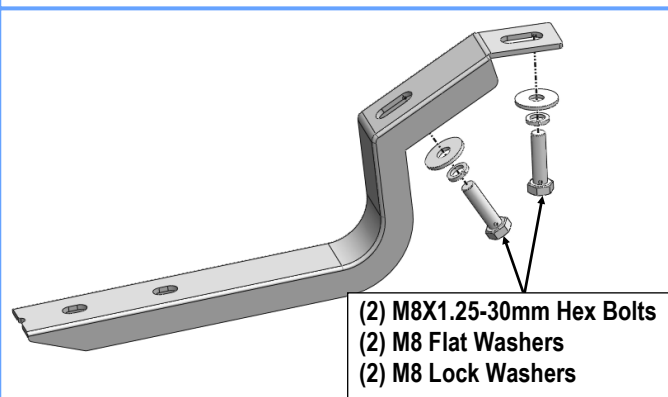

(Fig 2) Driver Front Mounting Bracket Installation

STEP 3

Move along the driver side center & rear mounting location, (**Fig 3 & 4**). Repeat **Steps 1-2** to install the Driver Center Mounting Bracket and Driver Rear Mounting Bracket.

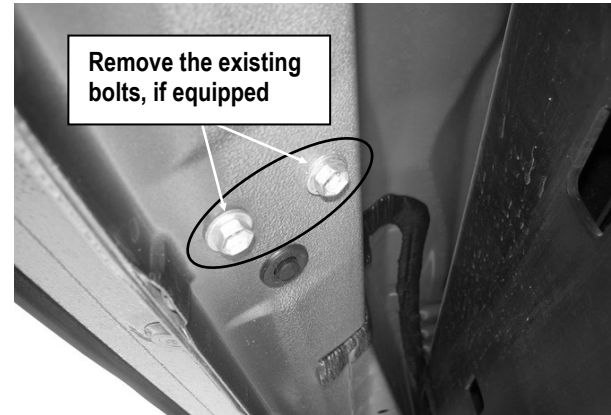

(Fig 3) Driver Side Center Mounting Location



(Fig 4) Driver Rear Mounting Bracket Installation

STEP 4

Once all (3) Driver side mounting brackets are installed, then proceed to the Step Bar installation. (**Figs 5&6**)

- (1) Select (1) Slider and (2) M8X1.25-35mm Carriage Bolts;
- (2) Install (2) M8X1.25-35mm Carriage Bolts in (1) Slider.



(3) Slide the Slider (with carriage bolts) to the **Step Bar**.

(4) Repeat to install the other (2) sliders to the step bar.

(5) Attach the Step Bar (with the Sliders) onto the installed mounting brackets. Position the Sliders to the installed brackets. Secure the Step Bar to the installed Brackets by using (6) M8 Large Flat Washers and (6) M8 Nylon Lock Nuts and (3) Sliders, (**Fig 6**).

Do not fully tighten hardware at this time.

Note: The Sliders are packed with the Step Bars.

Level and adjust the Step Bar and fully tighten all hardware.

Repeat **Steps 1-4** for the other side Step Bar installation. **The installation is completed!!!**

Attention

Do periodic inspections to the installation to make sure that all hardware is secure and tight.

In order to protect your bars/boards, please use mild soap/non-abrasive products for cleaning only.

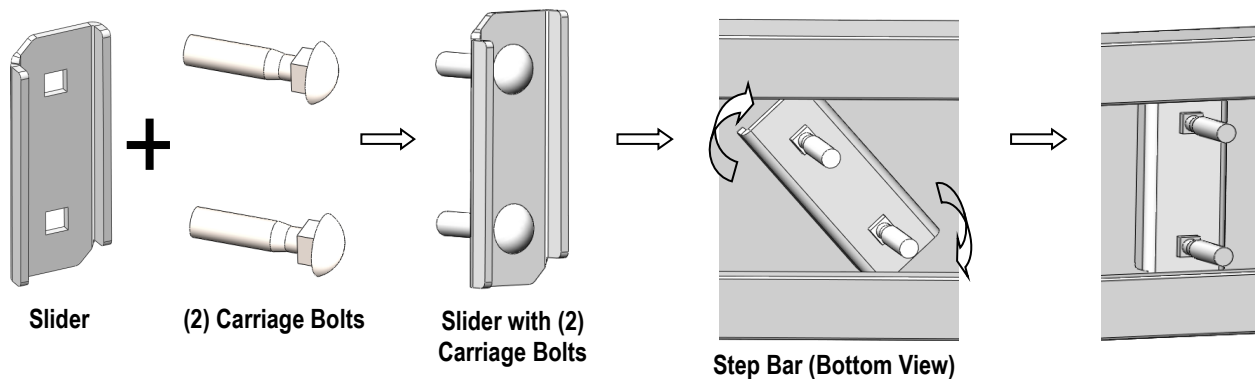

(Fig 5) Slider Installation

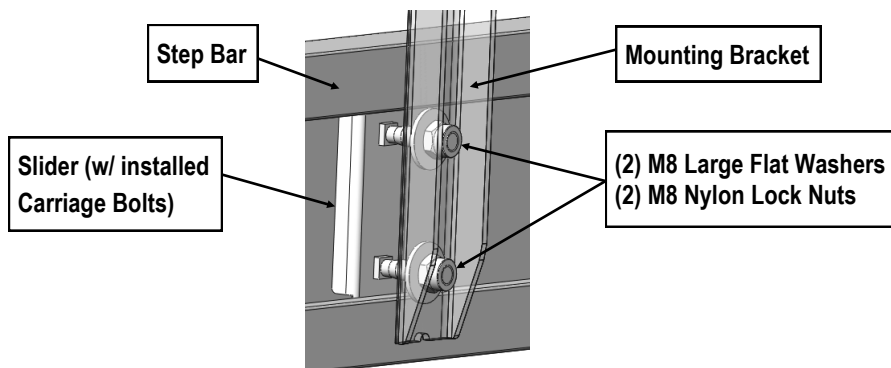

(Fig 6) Step Bar Installation