

iBoard®



Scan for
Installation Video

iBoard® by APS

PART#: IB-012C&H

READ INSTRUCTIONS CAREFULLY BEFORE STARTING INSTALLATION. REMOVE CONTENTS FROM BOX AND VERIFY ALL PARTS ARE PRESENT. ASSISTANCE IS RECOMMENDED.

*ROCKER PANEL MOUNT
*NO DRILLING REQUIRED

Fastener Size	Tightening Torque (ft-lbs)	Required
6mm	6-7	X
8mm	16-18	√
10mm	31-32	√
12mm	56-58	√
14mm	92-94	X

PART LIST

Driver Side Step Bar

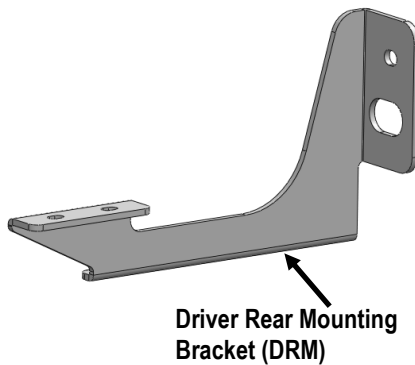
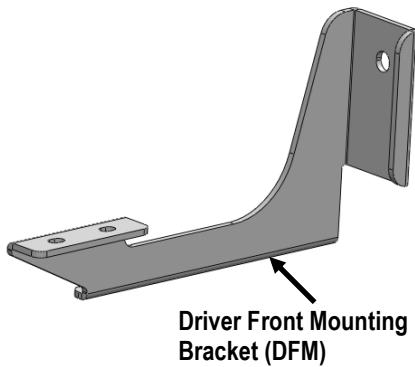
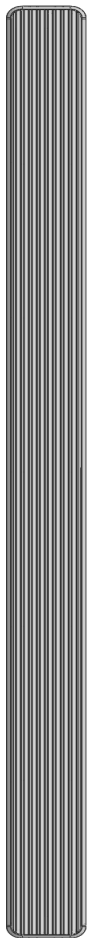

Front



Passenger Side Step Bar

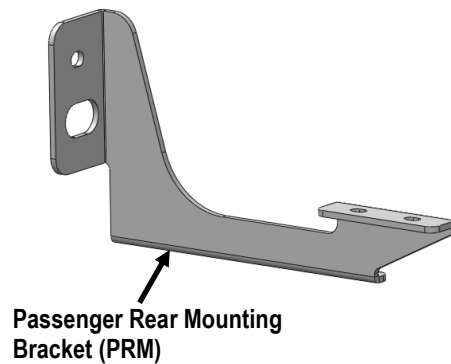
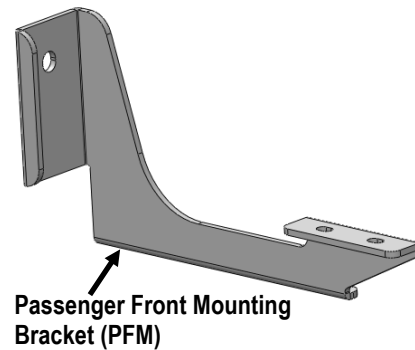
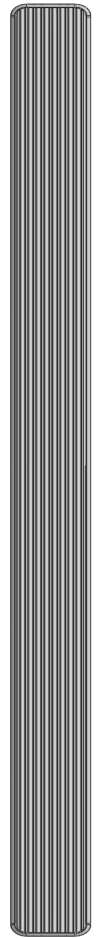

Customer Support: info@iboardauto.com



Hardware Package A (For Bracket Installation)

Item	QTY	Description	Item	QTY	Description
1#	2	M10 Bolt Plates	7#	2	M12 Lock Washers
2#	1	M12 Short Bolt Plates	8#	2	M12 Hex Nuts
3#	1	M12 Long Bolt Plates	9#	2	M10 Large Flat Washers
4#	2	M12 Plastic Washers	10#	2	M10 Lock Washers
5#	2	M10 Plastic Washers	11#	2	M10 Hex Nuts
6#	2	M12 Large Flat Washers			

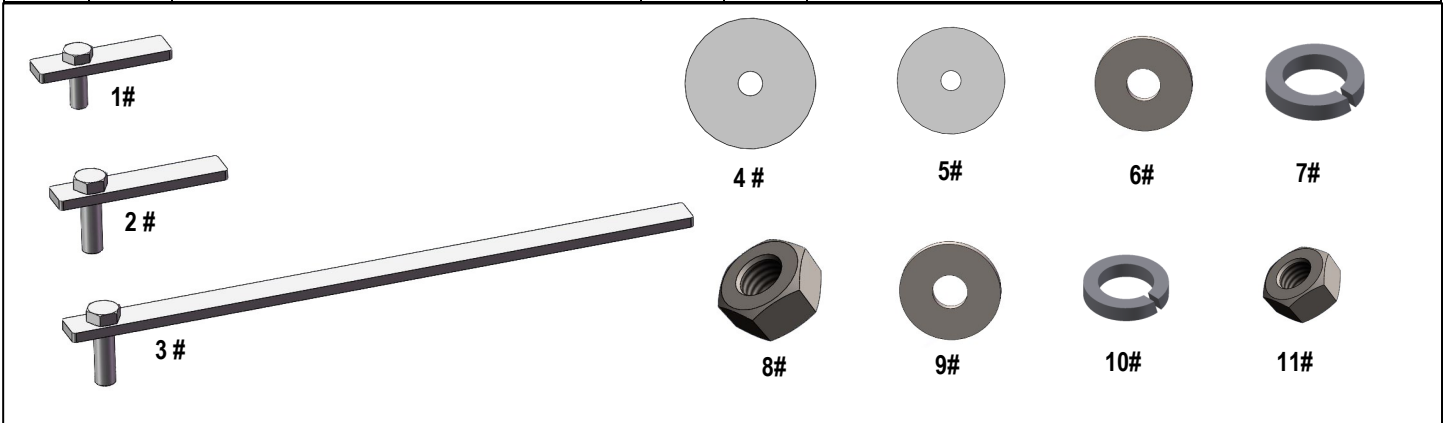

Hardware Package B (For Stainless Steel Step Bar Installation)

Item	QTY	Description	Item	QTY	Description
1#	8	M8X1.25-35mm Carriage Bolts	3#	8	M8 Nylon Lock Nuts
2#	8	M8 Large Flat Washers	4#	4	Sliders (Packed with Step Bars)

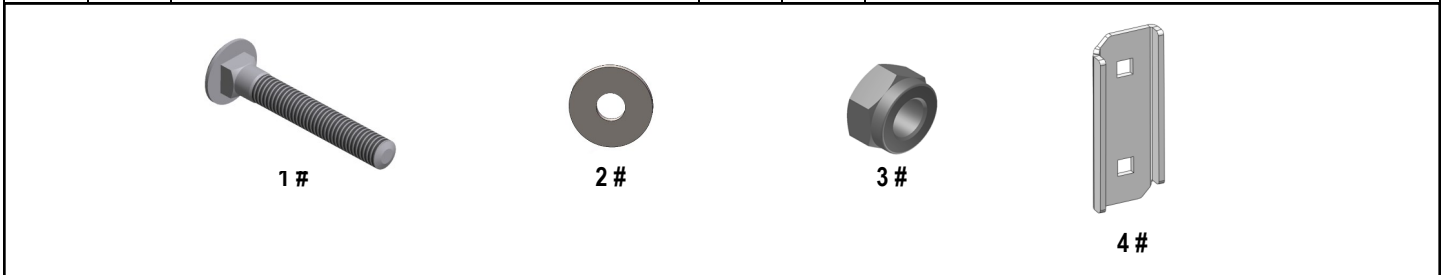



STEP 1

Starting on the driver side front of the vehicle, Locate the rectangular factory hole on the side of the frame behind the front body mount, (Fig 1).

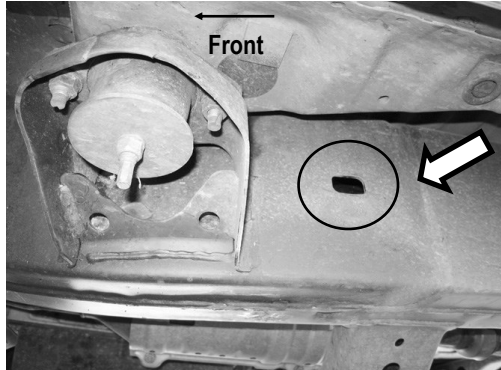

(Fig 1) Driver Side Front Mounting Location

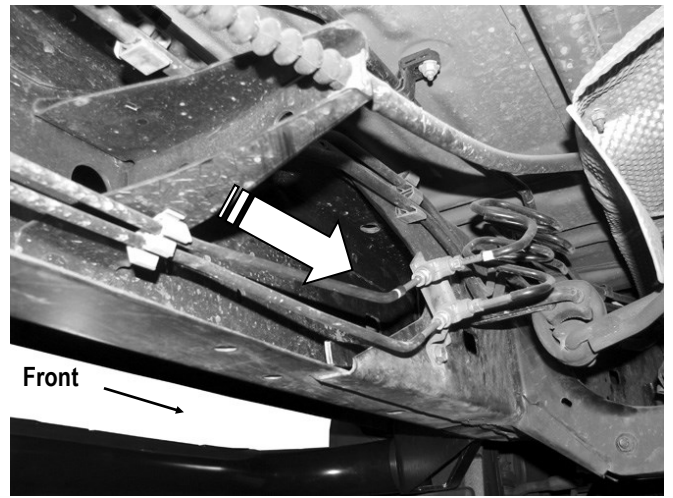

(Fig 2) M12 Long Bolt Plate Install Location
(On Driver Side Front Mounting Location)

STEP 2

Select (1) M12 Long Bolt Plate. Thread (1) M12 Plastic Washer onto the M12 Bolt Plate.

NOTE: Use the **M12 Long Bolt Plate** for **driver side** installation and the **M12 Short Bolt Plate** for **passenger side** front bracket installation.

From the back of the frame, insert the M12 Bolt Plate into the open end of the boxed frame, (Fig 2), and up to and out of the rectangular opening in the outside of the frame, (Fig 3). Line up the top hole in the Driver Front Mounting Bracket (DFM) with the M12 Bolt Plate. Attach the Bracket to the installed M12 Bolt Plate with (1) M12 Large Flat Washer, (1) M12 Lock Washer and (1) M12 Hex Nut (Fig 4). Do not fully tighten hardware at this time.

NOTE: Plastic Washer is designed to prevent the Bolt Plate from falling into the body cavity and hold the Bracket in place during installation.



(Fig 3) M12 Long Bolt Plate Installed Inside View
(In Frame Channel on Driver Side Front Mounting Location)

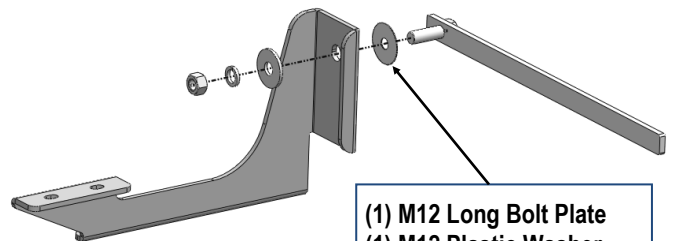

- (1) M12 Long Bolt Plate
- (1) M12 Plastic Washer
- (1) M12 Large Flat Washer
- (1) M12 Lock Washer
- (1) M12 Hex Nut

(Fig 4) Driver Front Mounting Bracket (DFM) Installation



STEP 3

Move to driver side rear mounting location, (Fig 5 & 6). From the back of the frame channel, insert the M10 Bolt Plate through the factory hole. Thread (1) M10 Plastic Washer onto the Bolt Plate.

Select the Driver Rear Mounting Bracket (DRM), attach the upper hole on the Bracket to the installed M10 Bolt Plate with (1) M10 Flat Washer, (1) M10 Lock Washer and (1) M10 Hex Nut, (Fig 7). Do not fully tighten hardware at this time.

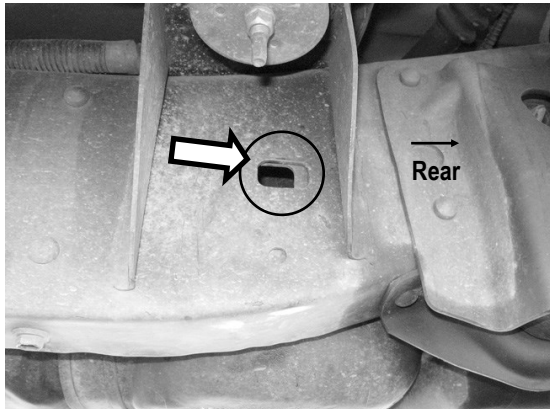

(Fig 5) Driver Side Rear Mounting Location

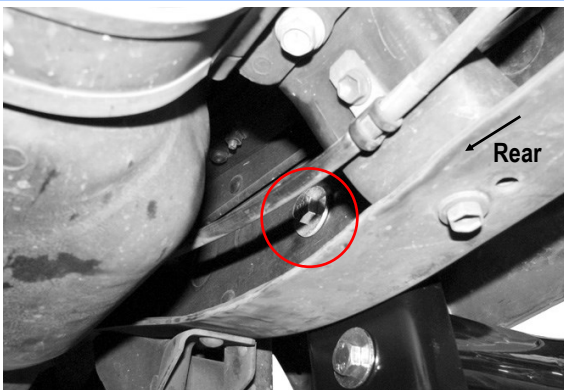

(Fig 6) Driver Rear Mounting Bracket Installation
(Back View Of Driver Side-Rear Frame Channel, Reference Only)

- (1) M10 Bolt Plate
- (1) M10 Plastic Washer
- (1) M10 Large Flat Washer
- (1) M10 Lock Washer
- (1) M10 Hex Nut

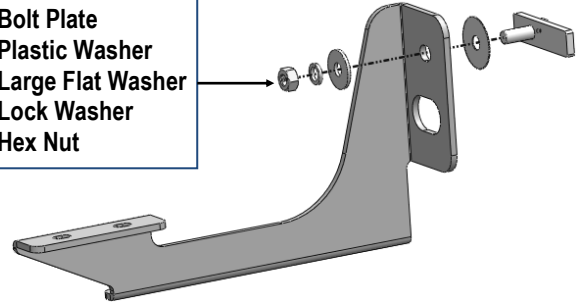

(Fig 7) Driver Rear Mounting Bracket (DRM) Installation

STEP 4

Once all (2) Driver side mounting brackets are installed, then proceed to the Step Bar installation. (Figs 8 & 9)

- (1) Select (1) Slider and (2) M8X1.25-35mm Carriage Bolts;
- (2) Install (2) M8X1.25-35mm Carriage Bolts in (1) Slider.
- (3) Slide the Slider (with carriage bolts) to the **Step Bar**.
- (4) Repeat to install the other (1) slider to the step bar.
- (5) Attach the Step Bar (with the Sliders) onto the installed mounting brackets. Position the Sliders to the installed brackets. Secure the Step Bar to the installed Brackets by using (4) M8 Large Flat Washers and (4) M8 Nylon Lock Nuts and (2) Sliders, (Fig 9). Do not fully tighten hardware at this time.

Note: The Sliders are packed with the Step Bars.

Level and adjust the Step Bar and fully tighten all hardware.

Repeat **Steps 1-4** for the other side Step Bar installation. **The installation is completed!!!**

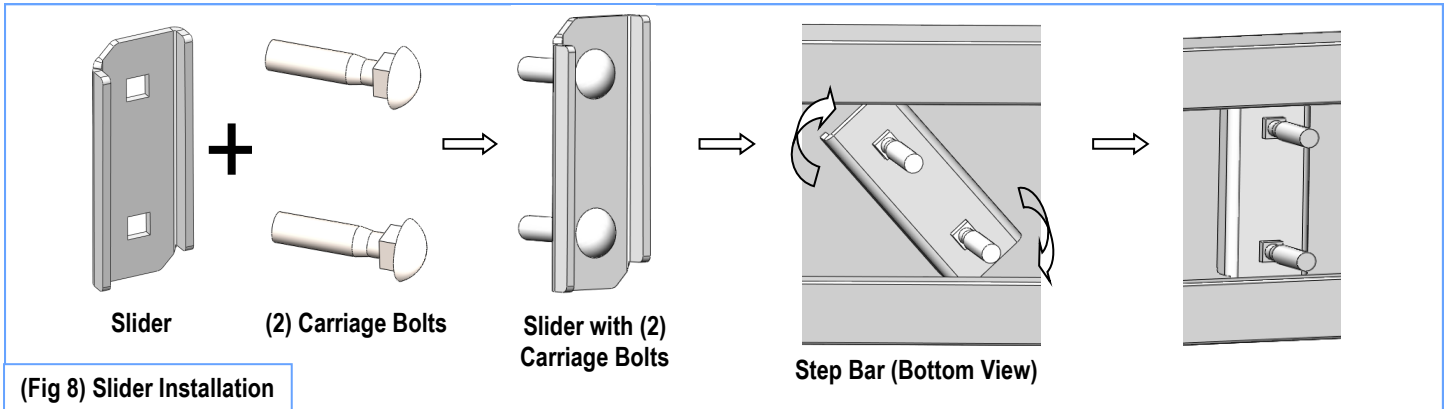

(Fig 8) Slider Installation

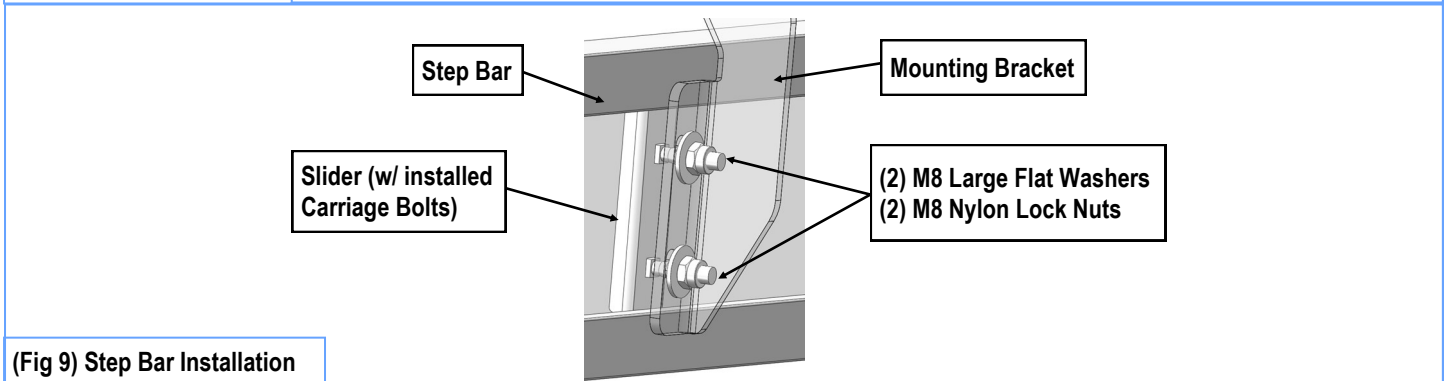

(Fig 9) Step Bar Installation

Attention

Do periodic inspections to the installation to make sure that all hardware is secure and tight.
In order to protect your bars/boards, please use mild soap/non-abrasive products for cleaning only.