

iBoard®



Scan for
Installation Video

iBoard® by APS

PART#: IB-362C&H

READ INSTRUCTIONS CAREFULLY BEFORE STARTING INSTALLATION. REMOVE CONTENTS FROM BOX AND VERIFY ALL PARTS ARE PRESENT. ASSISTANCE IS RECOMMENDED.

*ROCKER PANEL MOUNT

*NO DRILLING REQUIRED/ CUTTING IS REQUIRED

Fastener Size	Tightening Torque (ft-lbs)	Required
6mm	6-7	X
8mm	16-18	√
10mm	31-32	√
12mm	56-58	X
14mm	92-94	X

PART LIST

Driver Side Step Bar

Front
↑

Passenger Side Step Bar

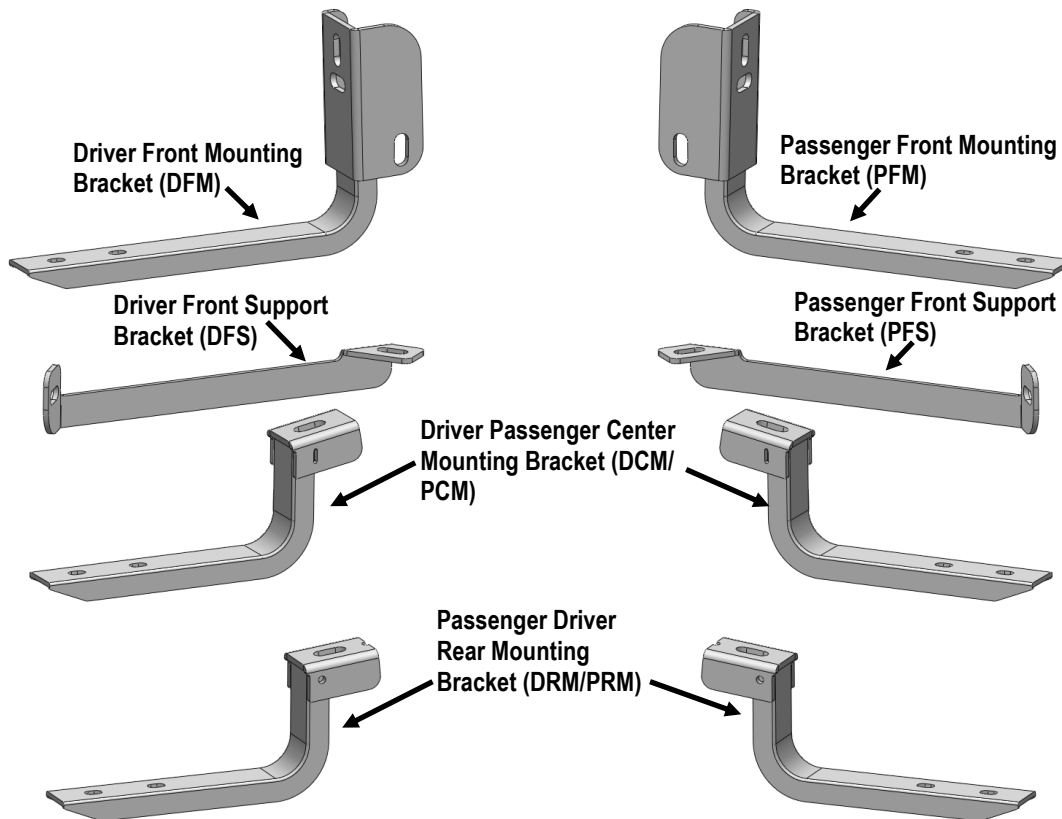
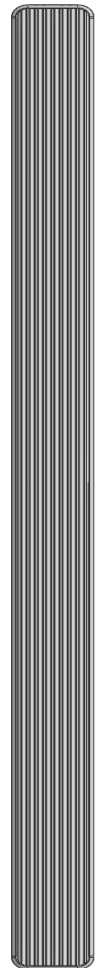
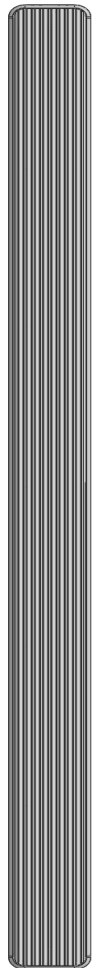

Customer Support: info@iboardauto.com



Hardware Package A (For Bracket Installation)

Item	QTY	Description	Item	QTY	Description
1#	1	Rivet Nut Installation Tool	7#	2	M10X1.5-25mm Hex Bolts
2#	2	M10X35 Bolt Plates	8#	14	M10 Large Flat Washers
3#	2	M10X50 T Block Bolts	9#	1	M10 Flat Washers
4#	8	M10 Plastic Washers	10#	12	M10 Hex Flange Nuts
5#	6	M10 J-Bolts	11#	1	M10 Hex Nuts
6#	1	M10X1.5-35mm Hex Bolts	12#	1	M10 Rivet Nuts

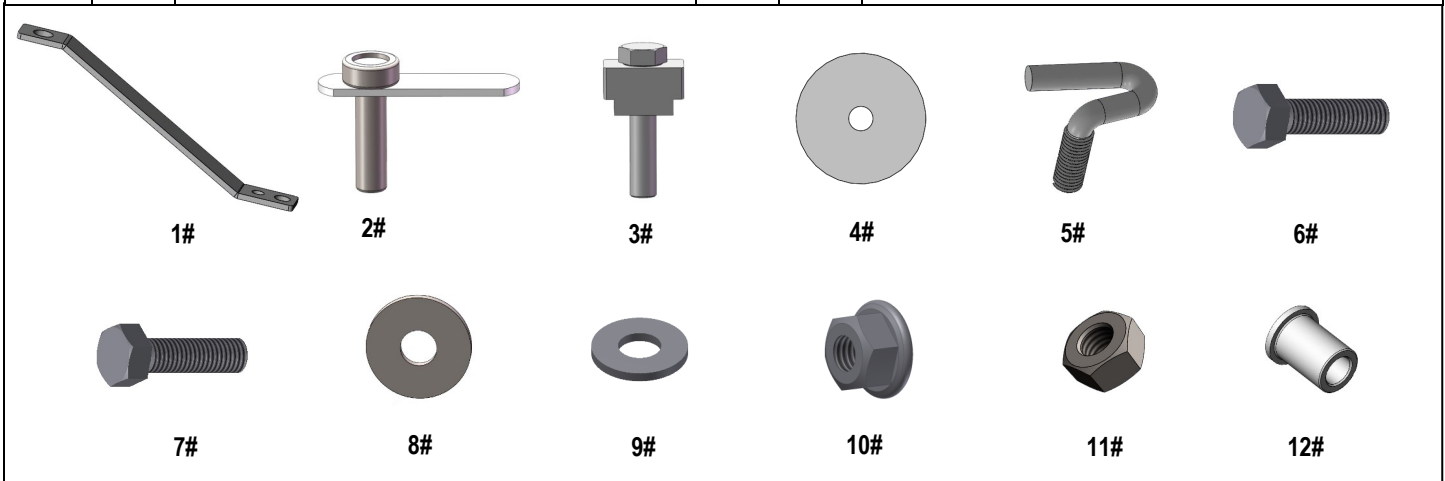

Hardware Package B (For Stainless Steel Step Bar Installation)

Item	QTY	Description	Item	QTY	Description
1#	12	M8X1.25-35mm Carriage Bolts	3#	12	M8 Nylon Lock Nuts
2#	12	M8 Large Flat Washers	4#	6	Sliders (Packed with Step Bars)

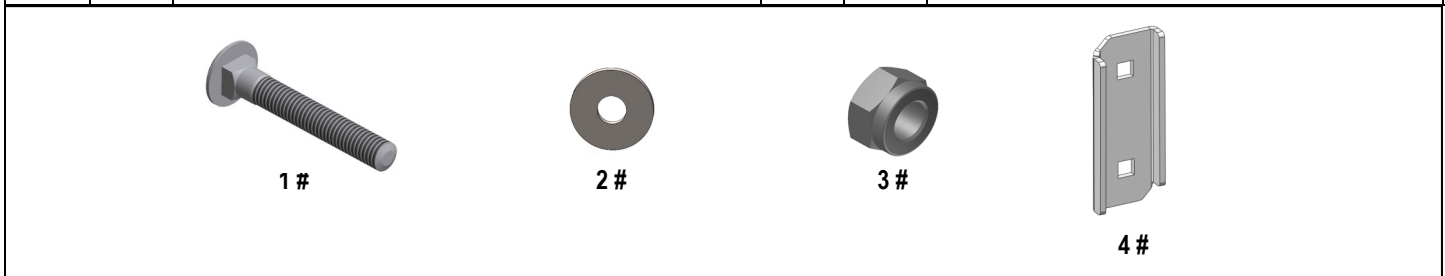



STEP 1

Start installation from the driver side front of the vehicle. Remove the plastic cover, **(Fig 1)**. Pay close attention to the type and location of all factory hardware for reinstallation.

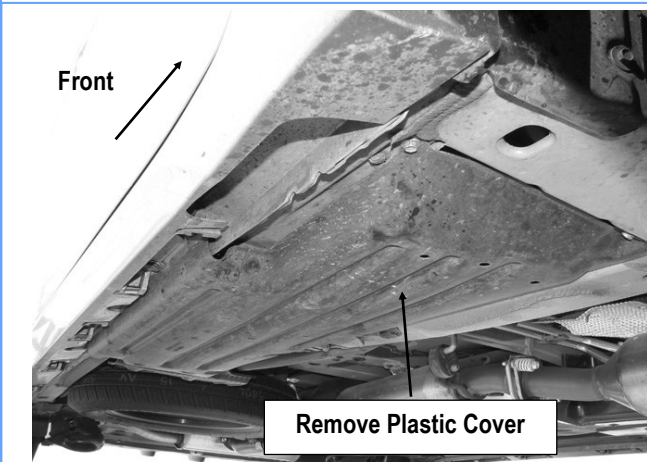

(Fig 1) Passenger Side Mounting Location

STEP 2

Locate the factory hole(s) in the inside wall of the floor panel, **(Fig 2)**. **NOTE:** The mounting locations may be covered by sealant or undercoating. Use a small screwdriver to poke through the sealant to uncover the hole.

IMPORTANT: Brackets must sit flat against sheet metal. Scrape any excess sealant from body panel before installing any and all Brackets.

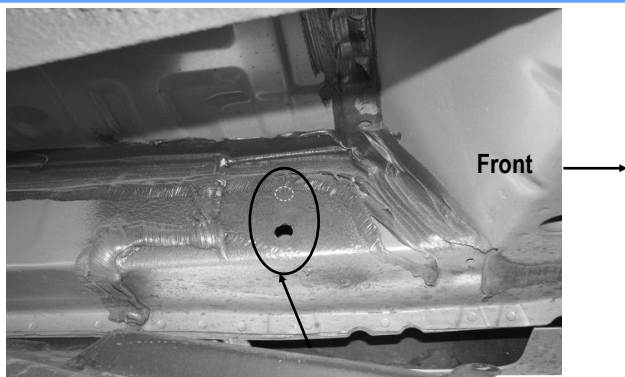

(Fig 2) 2011-14 Driver Side Front Mounting Location
(Remove Sealant As Necessary)

STEP 3

Select the correct driver side front bracket installation for your model year:

2011-14 models with (2) factory holes in driver side-front location. Also use for Passenger Mounting Bracket installation, all model years:

- Select (1) M10 J-Bolt and (1) M10 Plastic Washer, **(Fig 3)**. Partially thread the M10 Plastic Washer onto the J-Bolt. Insert the J-Bolt into the factory hole in the side panel, **(Fig 4)**. Thread the M10 Plastic Washer down until it is tight against the floor panel. The M10 Plastic Washer is designed to help hold the J-Bolt in place during Bracket installation.
- Repeat this Step to install the second J-Bolt in the remaining hole.
- Hang the Driver Front Mounting Bracket (**DFM**) from the (2) M10 J-Bolts with (2) M10 Large Flat Washers and (2) M10 Hex Flange Nuts, **(Fig 5)**. Do not fully tighten hardware at this time.

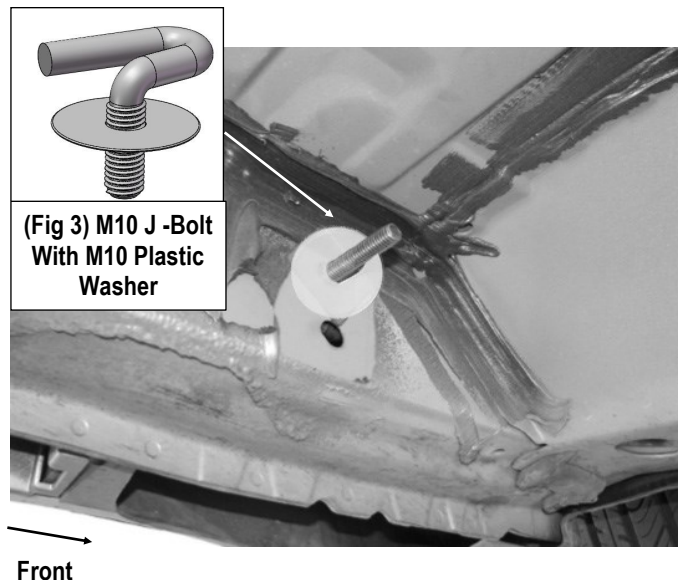

(Fig 4) Use Plastic Washer To Hold M10 J-Bolt In Place
(2011-14 models)

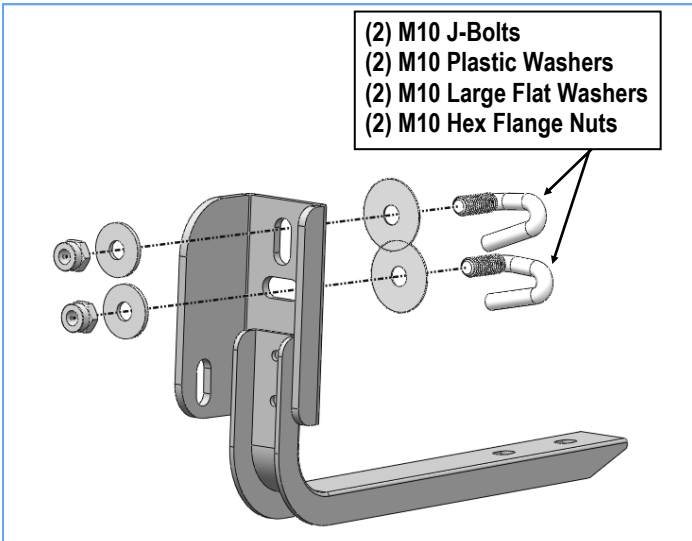

(Fig 5) Driver Front Mounting Bracket Installation

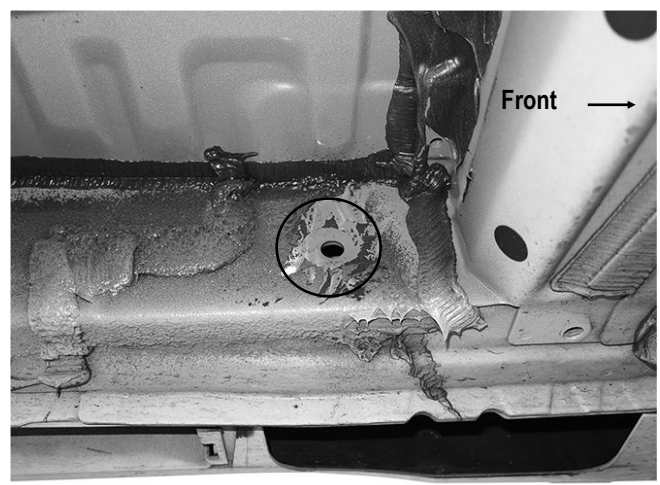

(Fig 6) Driver Side Front Mounting Location
Remove Sealant Covering Single Hole As Necessary
(2015-on models)

**2015-on with (1) factory hole in driver side-front location-
applies to Driver Front Mounting Bracket install only:**

- a. Locate the single factory hole as previously described in **Step 2, (Fig 6)**. Select the Rivet Nut Installation Tool, (1) M10 Rivet Nut, (1) M10 Large Flat Washer, (1) M10 Hex Nut and (1) M10X1.5-35mm Hex Bolt. Assemble the tool as pictured in **Fig 7**. **NOTE:** Select 10 mm hole on Insert Installation Tool, **(Fig 7A)**.
- b. Push the M10 Rivet Nut assembly into the factory hole. Hold tool handle and assembly up tight against the inner body panel. Tighten the M10 Hex Bolt until insert is fully expanded into hole, **(Fig 8)**. **NOTE:** Do not over tighten the Hex Bolt or damage to the insert, body panel or insert pull out may occur.
- c. Once Metal Insert is fully compressed, remove the bolt and tool from the Metal Insert.
- d. Line up the top slot in the Driver Front Mounting Bracket with the M10 Rivet Nut. Attach the Bracket to the M10 Rivet Nut with (1) M10X1.5-35mm Hex Bolt, (1) M10 Large Flat Washer and (1) M10 Lock Washer, **(Fig 9)**. Do not fully tighten hardware at this time.

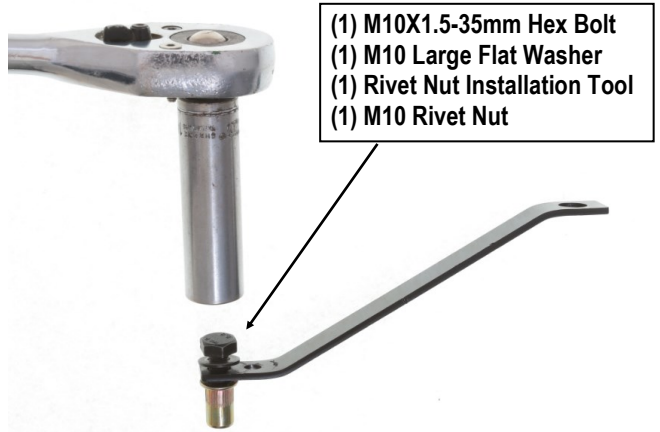

Fig 7

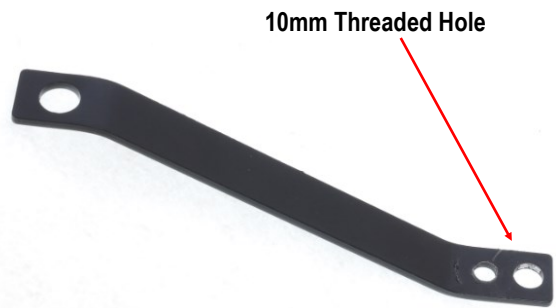
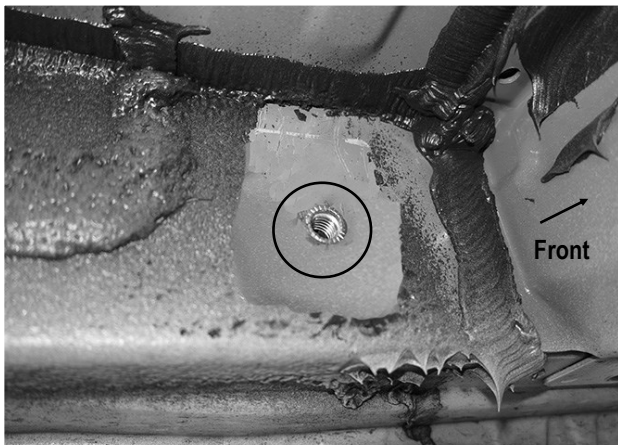
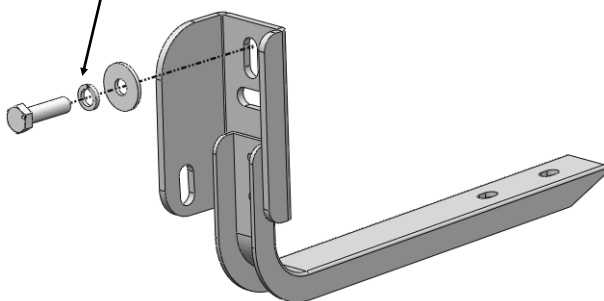

Fig 7A



(Fig 8) M10 Rivet Nut Installation On Driver Side
(2015-On Models)

- (1) M10X1.5-35mm Hex Bolt
- (1) M10 Lock Washer
- (1) M10 Large Flat Washer



(Fig 9) Driver Side Front Mounting Bracket Installation
(2015-On Models)

STEP 4

Next, remove the plastic plug from the bottom of the frame channel, (Fig 10). Select (1) M10X35 Bolt Plate and (1) M10 Plastic Washer, (Fig 11). Partially thread the M10 Plastic Washer onto the M10X35 Bolt Plate. Insert the M10X35 Bolt Plate into the hole in the bottom of the frame channel, (Fig 12). Thread the Plastic Washer down tight against the sheet metal to hold the Bolt Plate in place.

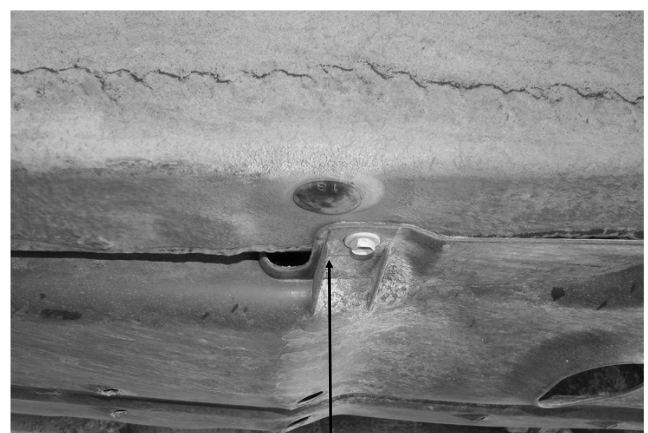

(Fig 10) Remove Plastic Plug On Bottom Of Frame Channel

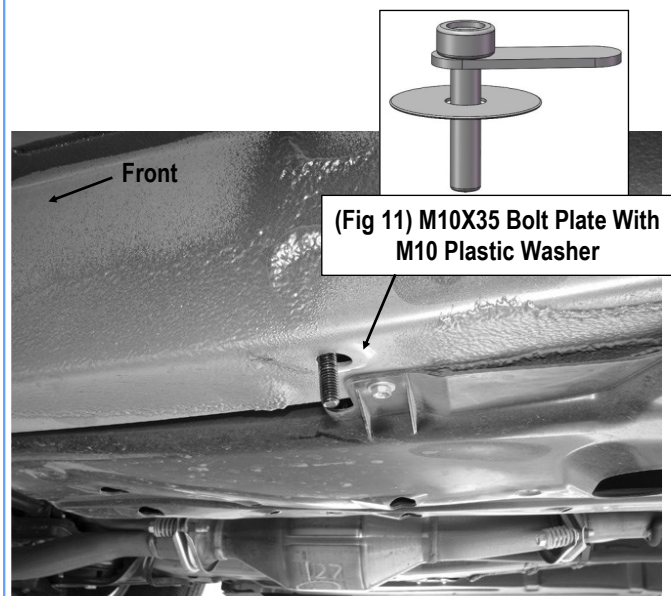

(Fig 12) Insert Bolt Plate With Plastic Washer Into Hole In Bottom
Of Frame Channel

STEP 5

Select the Driver Front Support Bracket (DFS). Secure the Bracket to the back of the Driver Front Mounting Bracket with (1) M10X1.5-25mm Hex Bolt, (2) M10 Large Flat Washers and (1) M10 Hex Flange Nut, (Fig 13). Attach the inner end of the Support Bracket to the M10X35 Bolt Plate with (1) M10 Large Flat Washer and (1) M10 Hex Flange Nut, (Fig 14). Do not fully tighten hardware at this time.

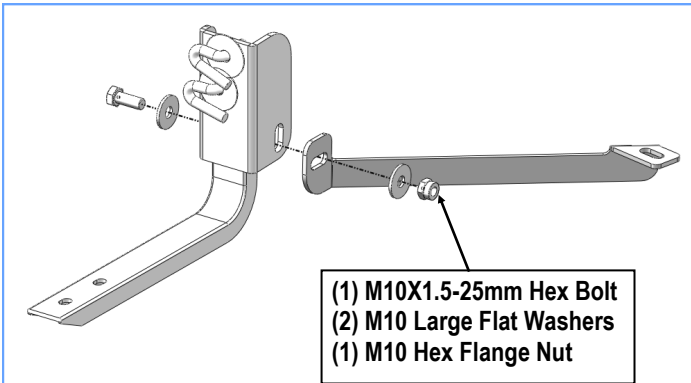

(Fig 13) Driver Front Support Bracket And Driver Front Mounting Bracket Assembly

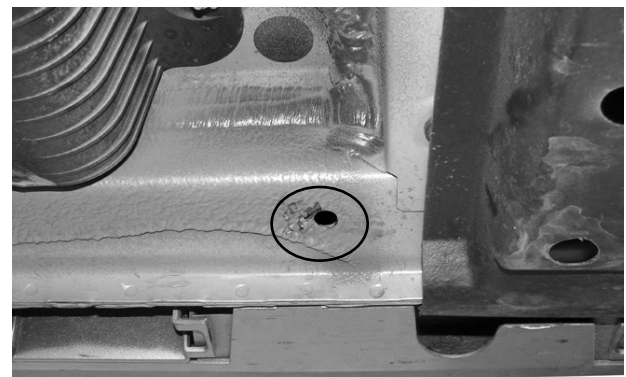

Front →

(Fig 15) Remove Sealant To Locate Factory Hole For Center Bracket

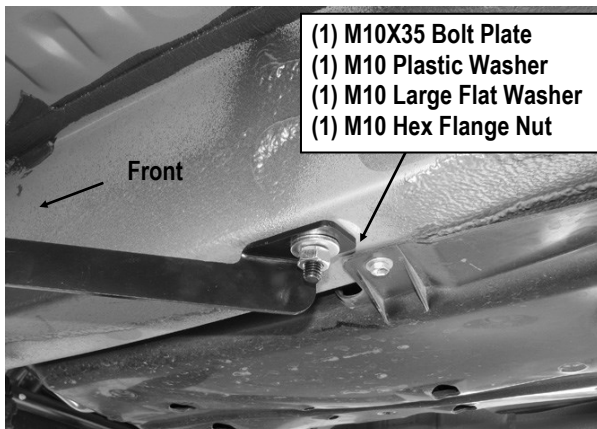

(Fig 14) Driver Front Support Bracket Installation

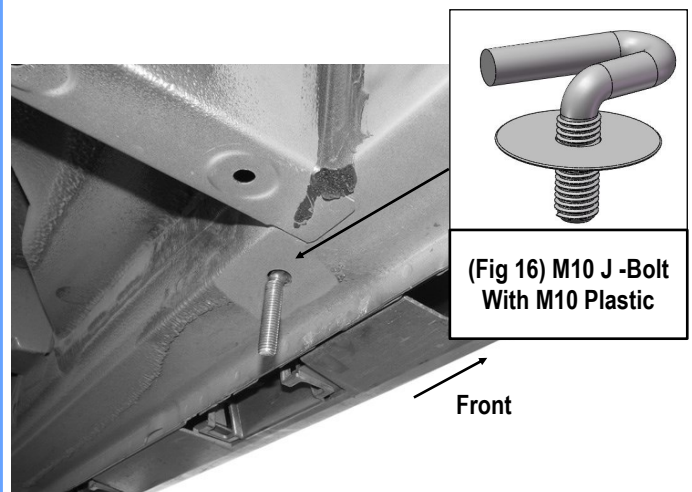

(Fig 17) Insert M10 J-Bolt With Plastic Washer Into The Hole

STEP 6

Move to the center of the vehicle. Locate the factory hole in the bottom of the outer frame channel, (Fig 15). **NOTE:** Hole may be covered with sealant as described in Step 2.

Select (1) M10 J-Bolt and (1) M10 Plastic Washer, (Fig 16). Insert J-Bolt into factory hole and tighten M10 Plastic Washer, (Fig 17). Select the Driver Center Mounting Bracket (DCM/PCM). Attach the Center Bracket to the J-Bolt with (1) M10 Large Flat Washer and (1) M10 Hex Flange Nut, (Fig 19). Do not fully tighten hardware at this time.

IMPORTANT: The Center and Rear Brackets are similar, but different, (Fig 18).

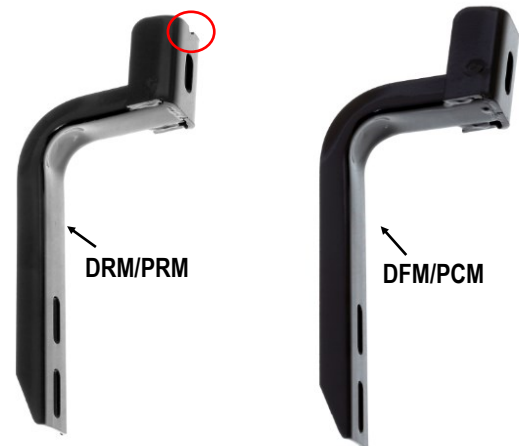
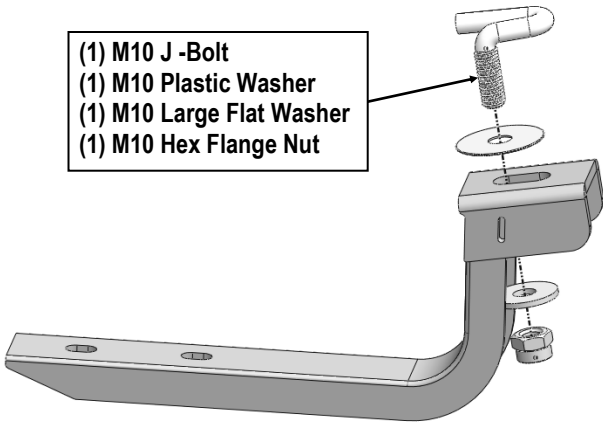

Fig 18



- (1) M10 J-Bolt
- (1) M10 Plastic Washer
- (1) M10 Large Flat Washer
- (1) M10 Hex Flange Nut



(Fig 19) Driver Center Mounting Bracket Installation

STEP 7

Move to the rear mounting location and locate the large oval hole in the floor panel. Select (1) M10X50 T Block Bolt and (1) M10 Plastic Washer, (Fig 20). Partially thread the M10 Plastic Washer onto the M10X50 T Block Bolt. Insert the M10X50 T Block Bolt into the oval hole in the floor panel and rotate Bolt 90-degrees so that the Block is across the oval hole, (Fig 21). Thread the Plastic Washer down until it is tight against the floor panel.

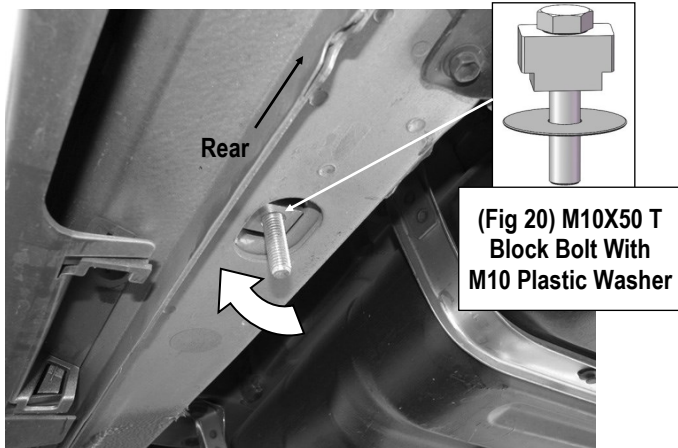

(Fig 21) Driver Side Rear Mounting Location

STEP 8

Select the Driver Rear Mounting Bracket (**DRM/PRM**). Attach the Bracket to the M10X50 T Block Bolt with (1) M10 Large Flat Washer and (1) M10 Hex Flange Nut, (Fig 22). Do not fully tighten hardware at this time.

- (1) M10X50 T Block Bolt
- (1) M10 Plastic Washer
- (1) M10 Large Flat Washer
- (1) M10 Hex Flange Nut

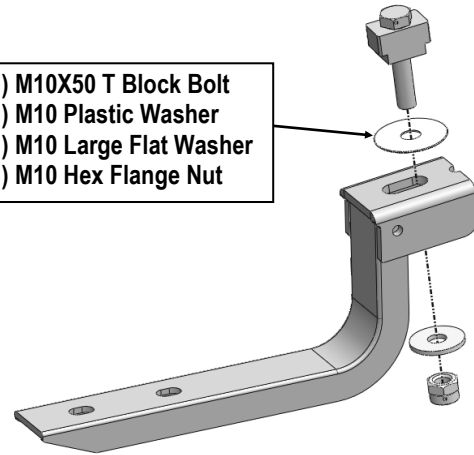

(Fig 22) Driver Rear Mounting Bracket Installation

STEP 8

Once all (3) Driver side mounting brackets are installed, then proceed to the Step Bar installation. (Figs 23 & 24)

- (1) Select (1) Slider and (2) M8X1.25-35mm Carriage Bolts;
- (2) Install (2) M8X1.25-35mm Carriage Bolts in (1) Slider.
- (3) Slide the Slider (with carriage bolts) to the **Step Bar**.
- (4) Repeat to install the other (2) sliders to the step bar.
- (5) Attach the Step Bar (with the Sliders) onto the installed mounting brackets. Position the Sliders to the installed brackets. Secure the Step Bar to the installed Brackets by using (6) M8 Large Flat Washers and (6) M8 Nylon Lock Nuts and (3) Sliders, (Fig 24). Do not fully tighten hardware at this time.

Note: The Sliders are packed with the Step Bars.

Level and adjust the Step Bar and fully tighten all hardware.

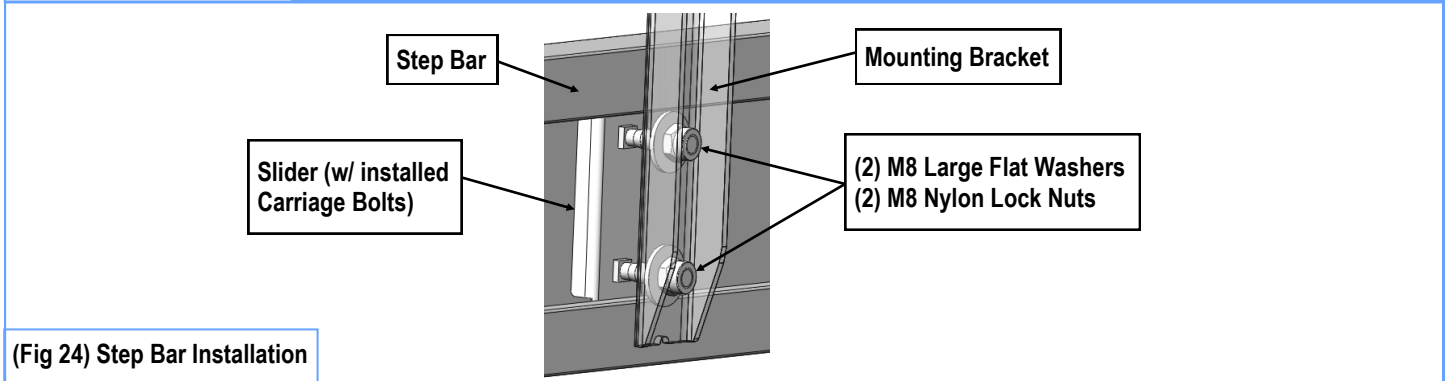
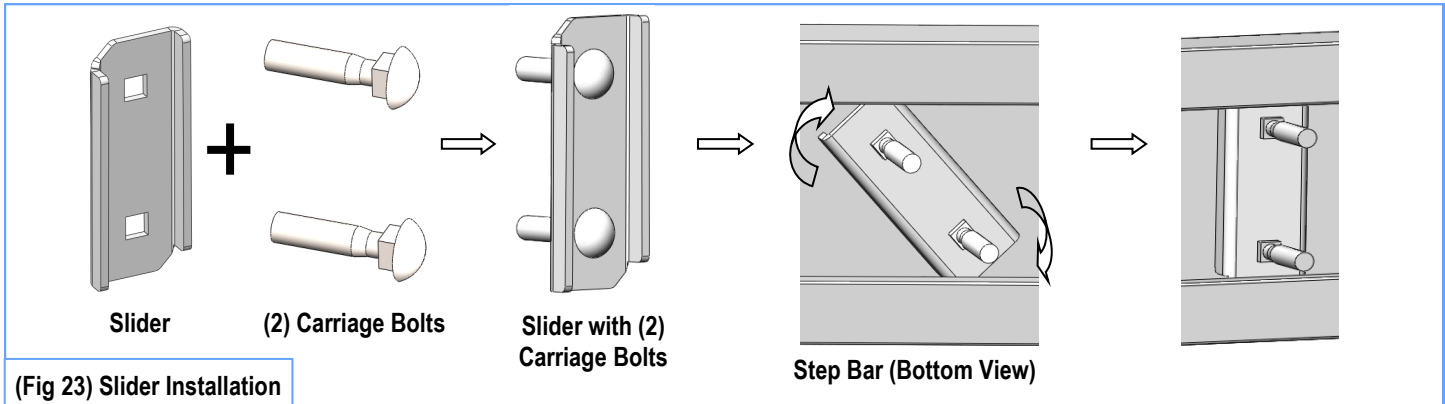

STEP 9

Level and adjust the Step Bar and fully tighten all hardware, except the hardware securing the front Support Bracket.

Once all other hardware has been tightened, temporarily remove the Front Support Bracket. Hold the plastic cover removed in **Step 1**, up in position. Trace the location of the Front Bracket onto the cover. Carefully cut the plastic cover to clear the Bracket, (Fig 25). **IMPORTANT:** Cut as little as possible from the cover. Reinstall the plastic cover with factory hardware. Reinstall the Support Bracket over the plastic cover as described in **Step 5**. Tighten all hardware.

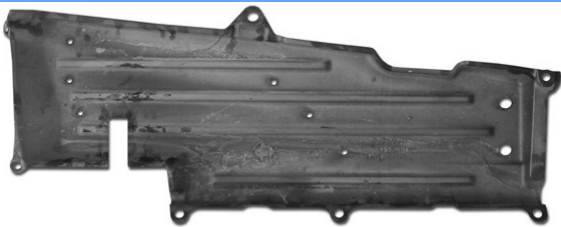

(Fig 25) Cut Cover Only Enough To Clear Bracket. (Example)

STEP 10

Repeat **Steps 1-10** for other side Step Bar installation. The installation is completed.

Note: Follow **2011-14** driver side front bracket installation instructions for passenger side front bracket installation.

Attention

Do periodic inspections to the installation to make sure that all hardware is secure and tight.

In order to protect your bars/boards, please use mild soap/non-abrasive products for cleaning only.