



Scan for
Installation Video

iBoard® by APS

PART#: IB-103C&H

READ INSTRUCTIONS CAREFULLY BEFORE STARTING INSTALLATION. REMOVE CONTENTS FROM BOX AND VERIFY ALL PARTS ARE PRESENT. ASSISTANCE IS RECOMMENDED.

*ROCKER PANEL MOUNT
*NO DRILLING REQUIRED

Fastener Size	Tightening Torque (ft-lbs)	Required
6mm	6-7	X
8mm	16-18	√
10mm	31-32	√
12mm	56-58	X
14mm	92-94	X

PART LIST

Driver Side Step Bar

Front
↑

Passenger Side Step Bar

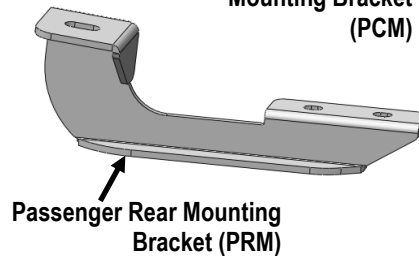
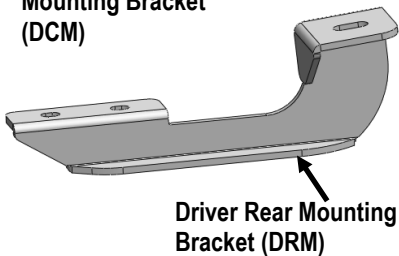
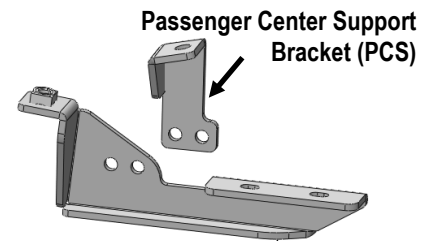
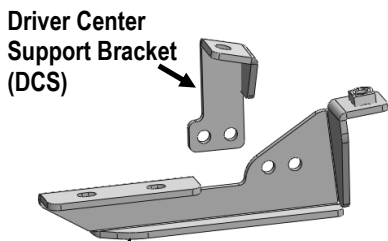
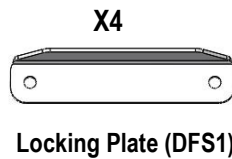
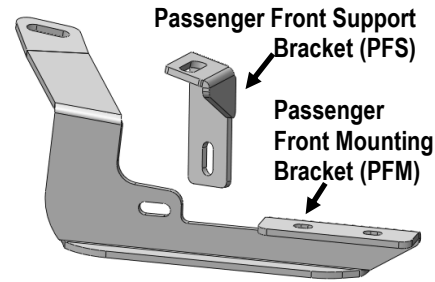
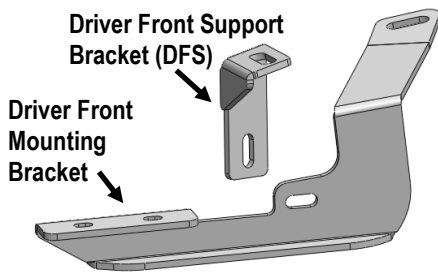
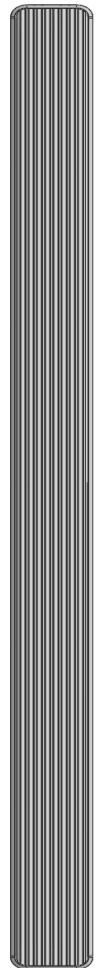
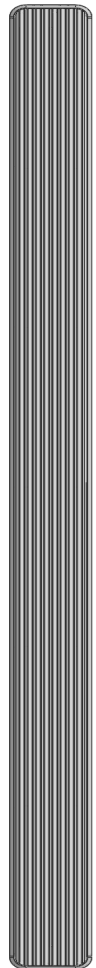









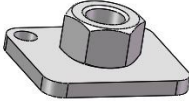

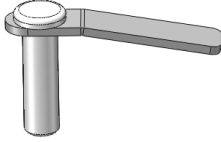
Customer Support: info@iboardauto.com

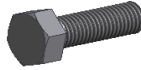

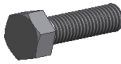

Scan for
Installation Video

Hardware Package A (For Bracket Installation)					
Item	QTY	Description	Item	QTY	Description
1#	2	Surface Reinforcement Plates	7#	8	M10 Flat Washers
2#	4	M10X50 T-Bolt Plates	8#	2	M10 Hex Nuts
3#	8	M10X35 Bolt Plates	9#	12	M10 Nylon Lock Nuts
4#	12	M10 Plastic Washers	10#	6	M8X1.25-30 Hex Bolts
5#	2	M10X1.5-40 Hex Bolts	11#	12	M8 Flat Washers
6#	4	M10 Large Flat Washers	12#	6	M8 Nylon Lock Nuts

					
1 #	2 #	3 #	4 #	5 #	6 #
					
7 #	8 #	9 #	10 #	11 #	12 #

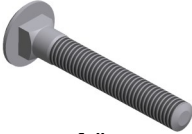
Hardware Package B (For Stainless Steel Step Bar Installation)					
Item	QTY	Description	Item	QTY	Description
1#	12	M8X1.25-35mm Carriage Bolts	3#	12	M8 Nylon Lock Nuts
2#	12	M8 Large Flat Washers	4#	6	Sliders (Packed with Step Bars)

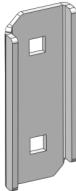
			
1 #	2 #	3 #	4 #



STEP 1

Start installation from the driver side front of the vehicle. Locate and remove the factory oval rubber plug and the (2) round rubber plugs in the bottom of the floor panel located closest to the front tire opening, **(Fig 1)**.

Select (1) M10X50 T-Bolt Plate and (1) M10 Plastic Washer, **(Fig 2A)**. Insert the T-Bolt up into the oval hole and rotate it 90-degrees so that the block is across the oval hole. Thread the Plastic Washer onto the T-Bolt and tight against the floor panel, **(Fig 2B)**. **NOTE:** The Plastic Washer is designed to help hold the T-Bolt in place during Bracket installation.

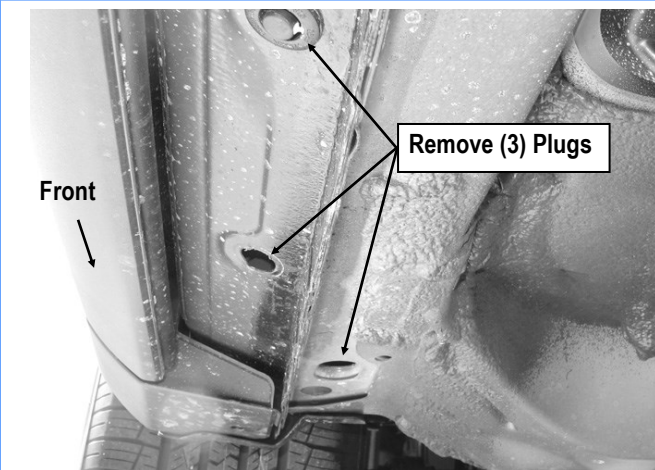

(Fig 1) Driver Side Front Mounting Location

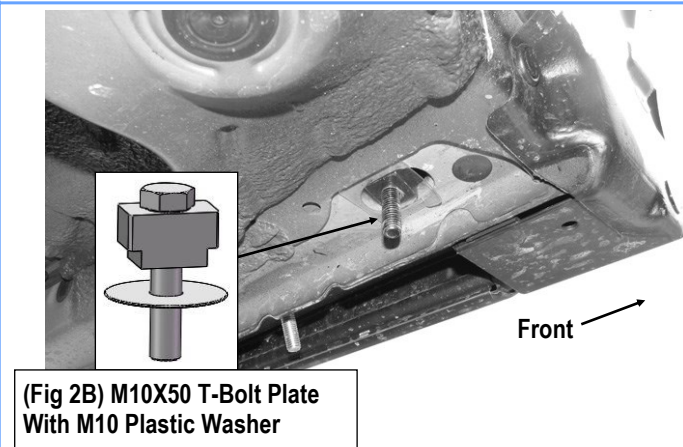

(Fig 2B) M10X50 T-Bolt Plate With M10 Plastic Washer

(Fig 2A) Insert the M10X50 T-Bolt Plate (Driver Front Side)

STEP 2

Next, select (2) M10X35 Bolt Plates and (2) M10 Plastic Washers. Insert (1) Bolt Plate with (1) Plastic Washer into each round hole in the floor panel next to the pinch weld, **(Fig 3A&3B)**.

IMPORTANT: Install the Bolt Plates with the "Plates" pointing toward each other, **(Fig 4)**. Thread the washer down tight against the floor panel. Select (1) Locking Plate **(DFS1)**. Slide the Locking Plate over the (2) Bolt Plates. Secure the Locking Plate to the rear Bolt Plate only with (1) M10 Flat Washer and (1) M10 Nylon Lock Nut, **(Fig 5)**. Do not fully tighten hardware.

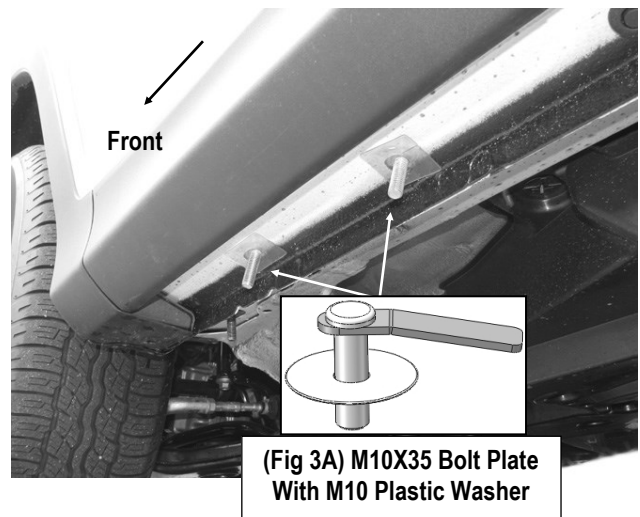

(Fig 3A) M10X35 Bolt Plate With M10 Plastic Washer

(Fig 3B) Insert the M10X35 Bolt Plate

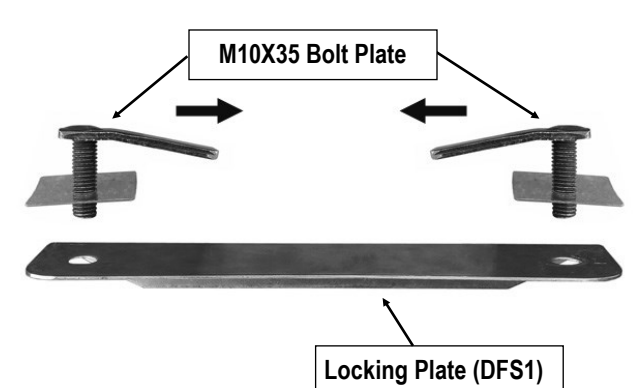

(Fig 4) Install Bolt Plates With Plates Pointing Towards Each Other

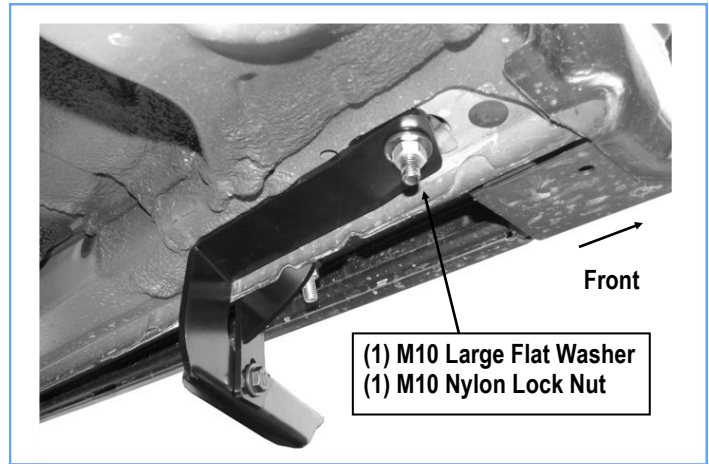
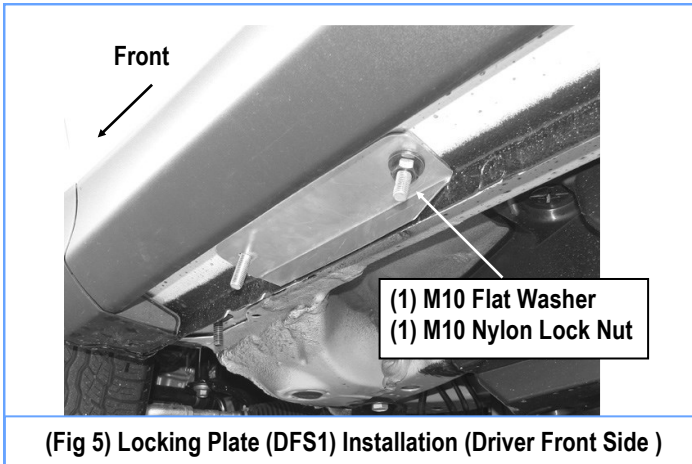

STEP 3

Select (1) Driver Front Mounting Bracket (**DFM**) and (1) Driver Front Support Bracket (**DFS**). Assembly with (1) M8X1.25-30 Hex Bolt, (2) M8 Flat Washers and (1) M8 Nylon Lock Nut, (**Fig 6**). Do not fully tighten hardware at this time.

Secure the Driver Front Mounting Bracket (**DFM**) to the M10X50 T-Bolt Plate with (1) M10 Flat Washer and (1) M10 Nylon Lock Nut, (**Fig 7A**). Do not fully tighten hardware at this time.

Slide the Driver Front Support Bracket (**DFS**) onto the M10x35 Bolt Plate and over the Lock Plate secure with (1) M10 Flat Washer and (1) M10 Nylon Lock Nut, (**Fig 7B**). Do not fully tighten hardware at this time.

(Fig 7A) Driver Side Front Mounting Bracket Installation

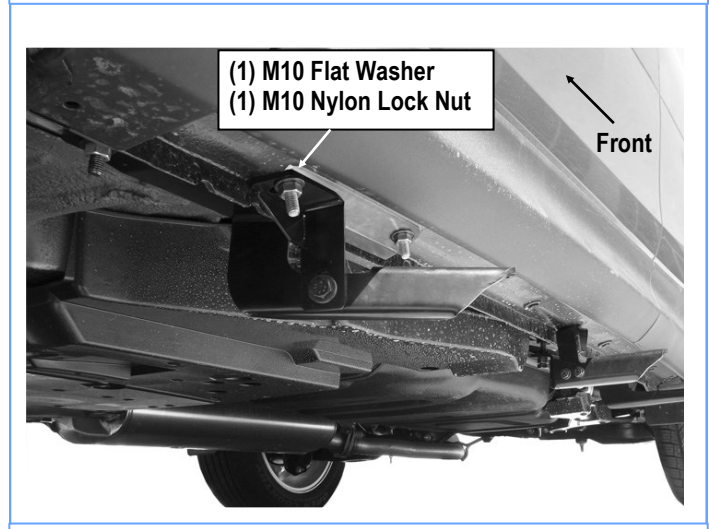

(Fig 7B) Driver Side Front Support Bracket Installation

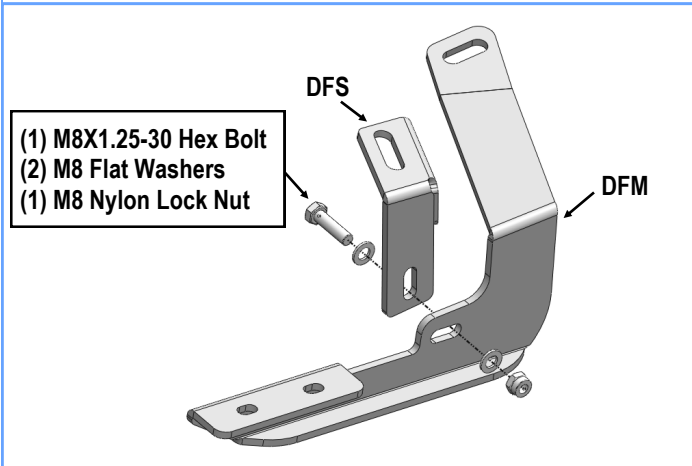

(Fig 6) Driver Side Front Bracket Assembly

STEP 4

Move along the side of the vehicle to the center location below where the front and rear doors meet. Locate the 4th and 5th hole in the floor panel from the front wheel opening, (**Fig 8**). Remove the (2) rubber plugs. Insert (2) M10X35 Bolt Plates and (2) M10 Plastic Washers, (**Fig 9A**), as described in **Step 2**, (**Figs 9A & 9B**). **IMPORTANT:** Install the Bolt Plates with the "Plates" pointing toward each other, (see **Fig 4**).

Attach (1) Locking Plate to the (2) Bolt Plates with (1) M10 Flat Washer and (1) M10 Nylon Lock Nut, (**Fig 10**). Do not fully tighten hardware.



Locate the 4th and 5th rubber plugs along the floor panel back from the front fender opening

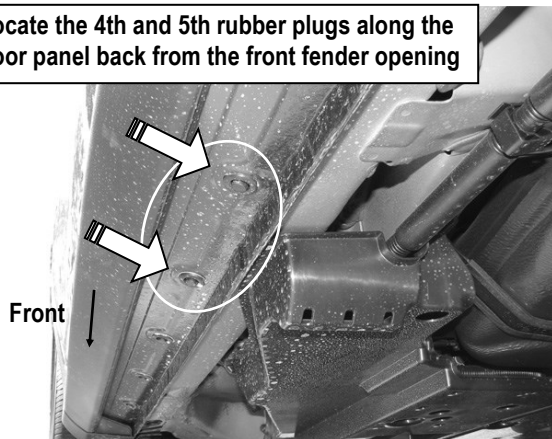

(Fig 8) Driver Side Center Mounting Location

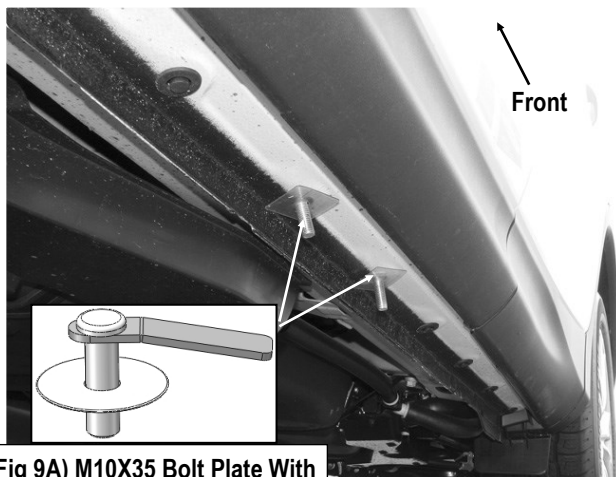

(Fig 9A) M10X35 Bolt Plate With M10 Plastic Washer

(Fig 9B) Insert the M10X35 Bolt Plate



(Fig 10) Locking Plate (DFS1) Installation (Driver Center Side)

STEP 5

Select (1) Driver Center Mounting Bracket (**DCM**) and (1) Driver Center Support Bracket (**DCS**). Assembly with (2) M8X1.25-30 Hex Bolts, (4) M8 Flat Washers and (2) M8 Nylon Lock Nuts, (**Fig 11**). Do not fully tighten hardware at this time.

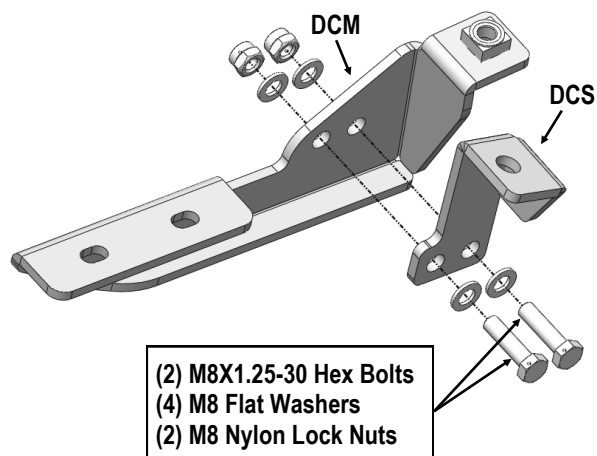

(Fig 11) Driver Side Center Bracket Assembly

STEP 6

Select (1) Driver Center Mounting Bracket (**DCM**), (1) M10X1.5-40 Hex Bolt, (1) Surface Reinforcement Plate and (1) M10 Hex Nut. Thread the M10 Hex Nut all the way down the M10X1.5-40 Hex Bolt. Insert the Hex Bolt with Nut up and into the welded nut on the tab on the Center Bracket, (**Fig 12**). **NOTE:** Thread the Bolt in until a few threads are sticking out of the welded nut. Do not thread the hex bolt all of the way into the welded nut. Place (1) Surface Reinforcement Plate onto the threaded end of the M10X1.5-40 Hex Bolt, (**Fig 12**). Continue to thread the Hex Bolt in until the Reinforcement Plate is close to but not touching the bottom of the body panel.

IMPORTANT: Do not tighten the hardware on the Center Brackets until the **final Steps**, (see **Step 13**).

Select (1) Driver Center Support Bracket (**DCS**), hang the Center Support Bracket onto the M10x35 Bolt Plate and over the Lock Plate secure with (1) M10 Flat Washer and (1) M10 Nylon Lock Nut, (**Fig 13**). Do not fully tighten hardware at this time.

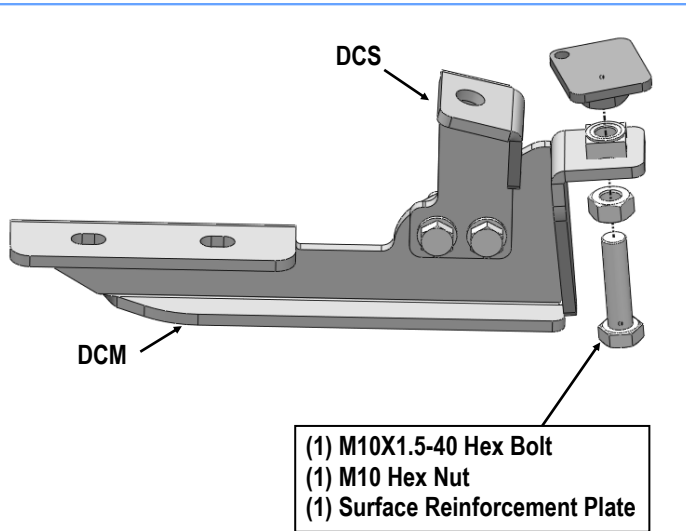

(Fig 12) Driver Side Center Mounting Bracket Installation

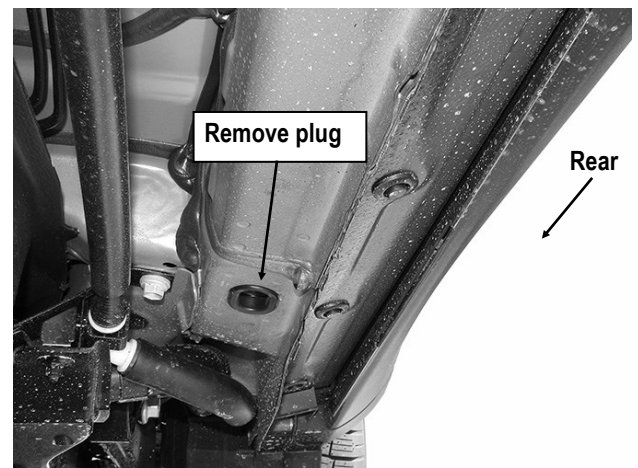

(Fig 14) Driver Side Rear Mounting Location

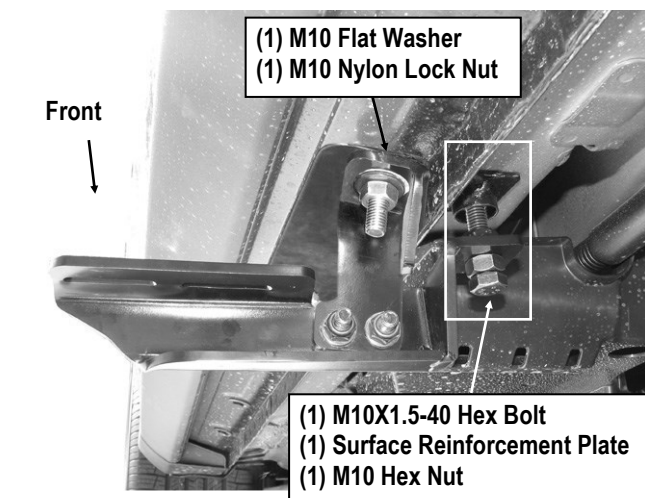

(Fig 13) Driver Side Center Mounting Bracket Installation

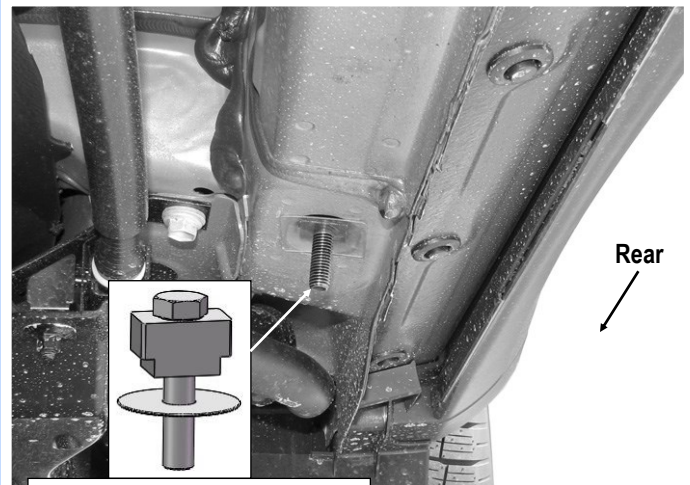

(Fig 15B) Insert the M10X50 T-Bolt Plate (Driver Rear Side)

STEP 7

Move to the rear of the vehicle, (Fig 14). Remove the oval rubber plug. Select (1) M10X50 T-Bolt Plate with (1) M10 Plastic Washer, (Fig 15A). Insert the T-Bolt up into the oval hole and rotate 90-degrees so that the block is across the oval hole. Thread the Plastic Retainer onto the T-Bolt and tight against the floor panel as described in Step 1, (Fig 15B).

STEP 8

Select the Driver Rear Mounting Bracket (DRM). Hang the Rear Bracket from the T-Bolt with (1) M10 Large Flat Washer and (1) M10 Nylon Lock Nut, (Fig 16). Do not fully tighten hardware.



- (1) M10 Large Flat Washer
- (1) M10 Nylon Lock Nut

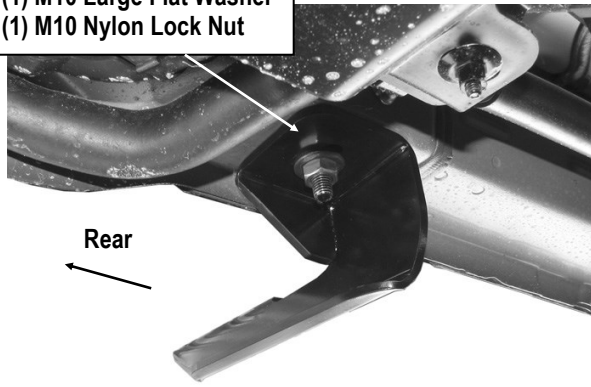

(Fig 16) Driver Side Rear Mounting Bracket Installation

STEP 9

Once all (3) Driver side mounting brackets are installed, then proceed to the Step Bar installation. (Figs 17 & 18)

- (1) Select (1) Slider and (2) M8X1.25-35mm Carriage Bolts;
- (2) Install (2) M8X1.25-35mm Carriage Bolts in (1) Slider.
- (3) Slide the Slider (with carriage bolts) to the **Step Bar**.
- (4) Repeat to install the other (2) sliders to the step bar.
- (5) Attach the Step Bar (with the Sliders) onto the installed mounting brackets. Position the Sliders to the installed brackets. Secure the Step Bar to the installed Brackets by using (6) M8 Large Flat Washers and (6) M8 Nylon Lock Nuts and (3) Sliders, (Fig 18). Do not fully tighten hardware at this time.

Note: The Sliders are packed with the Step Bars.

Level and adjust the Step Bar and fully tighten all hardware.

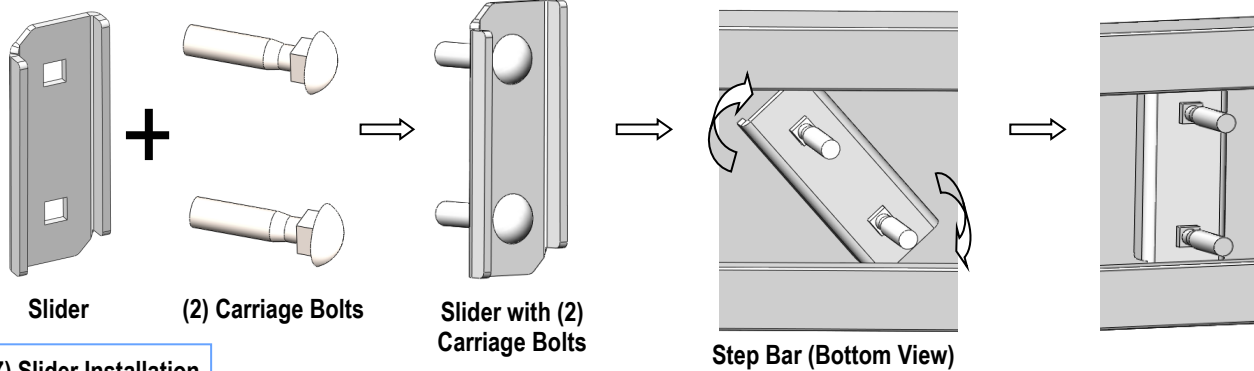

(Fig 17) Slider Installation

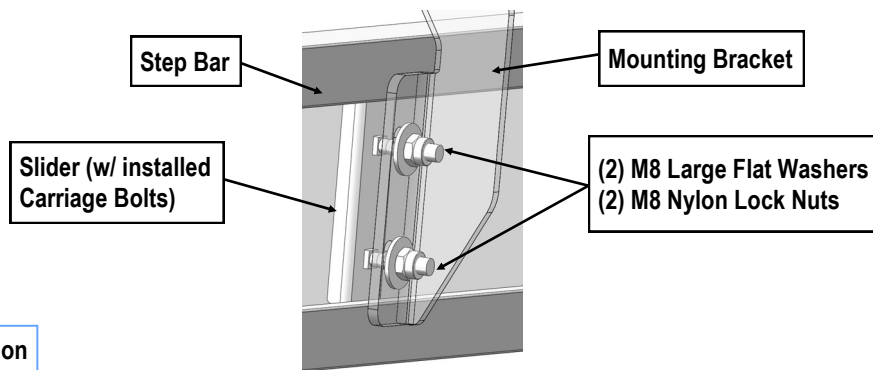

(Fig 18) Step Bar Installation



STEP 10

Check to see if the Step Bar is level to the car, front to rear, not level to the ground. Adjust the Brackets in or out as necessary to line up the Step Bar with the side of the vehicle. Move to the rear Bracket and once aligned, tighten the M10 Nylon Lock Nut on the T-Bolt, **(Fig 16)**.

STEP 11

Next, move to the front Bracket. Tighten the T-Bolt and Bolt Plate hardware only, **(Figs 7A & 7B)**. Adjust the height of the front Bracket as necessary. Once properly adjusted, tighten the M10 Hex Bolt securing the Support Bracket to the front Mounting Bracket, **(Fig 7B)**.

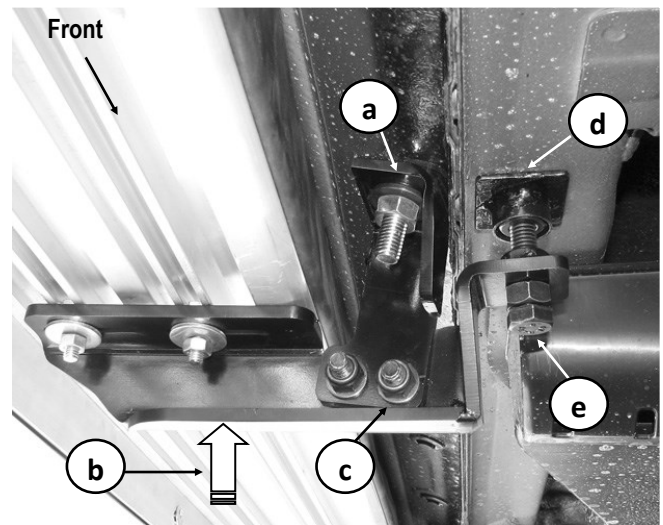

(Fig 19) Driver Side Center Mounting Bracket Pictured

STEP 12

With the front and rear Brackets fully tightened to the vehicle, move to the Center Bracket, **(Fig 19)**.

- Fully tighten the M10 Nylon Lock Nut securing the Support Bracket to the Bolt Plate.
- Gently push the Mounting Bracket up against and level to the bottom of the Step Bar.
- Tighten the (2) M8 Hex Bolts.
- Slowly tighten the M10X1.5-40 Hex Bolt until the Surface Reinforcement Plate is snug against the bottom of the body panel.
- Turn the Hex Bolt (2) full turns tighter to add preload. Tighten the M10 Nylon Lock Nut to lock the Bolt in place.

STEP 13

Level and adjust the Step Bar and fully tighten all hardware.

STEP 14

Repeat **Steps 1-14** for other side Step Bar installation. The installation is completed.

Attention

Do periodic inspections to the installation to make sure that all hardware is secure and tight.

In order to protect your bars/boards, please use mild soap/non-abrasive products for cleaning only.